

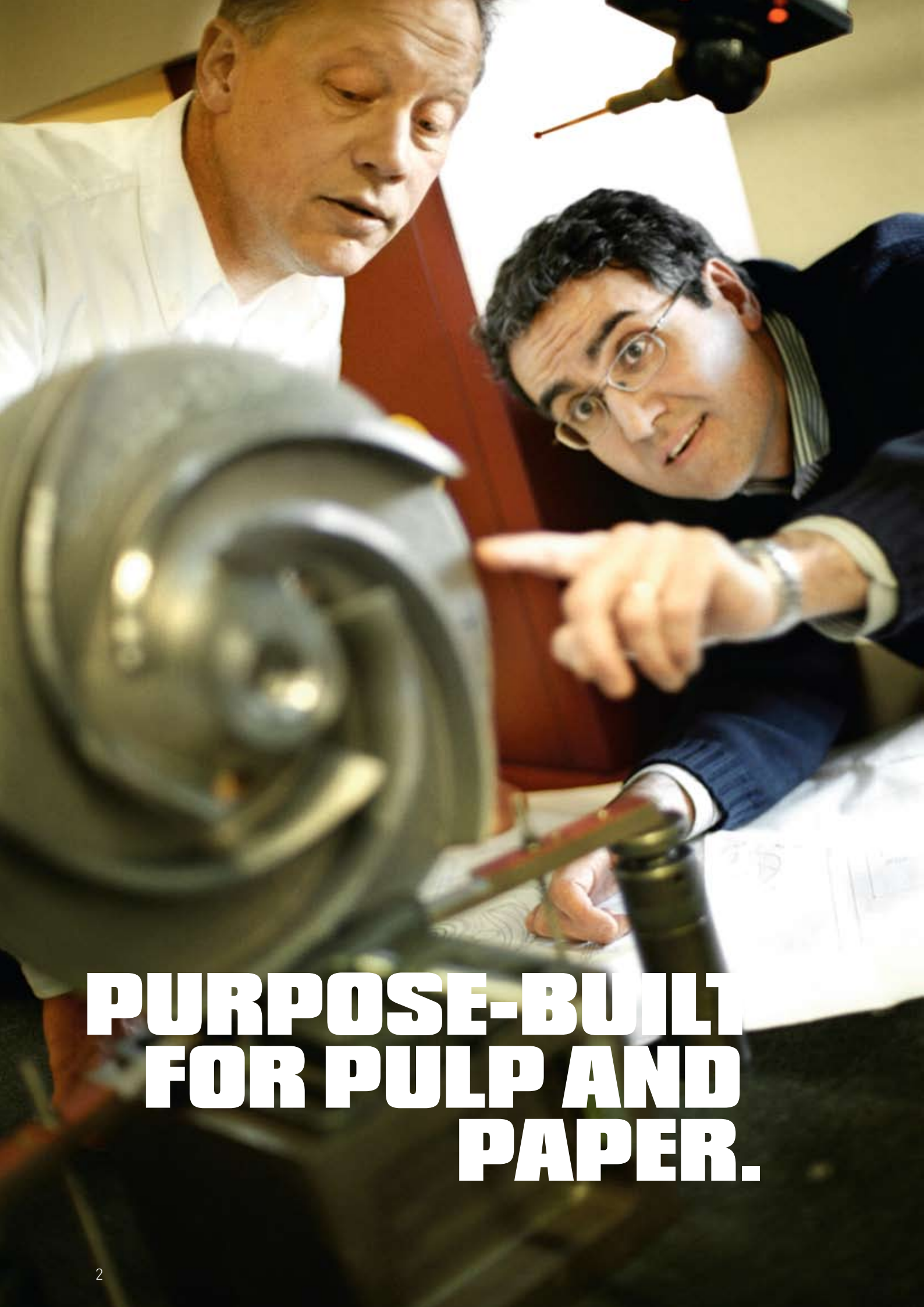

**SCANPUMP PROCESS  
PUMPS, BE SERIES.**

**NO-COMPROMISE  
PUMPING.**



**PURPOSE-BUILT  
FOR PULP AND  
PAPER.**

In many ways, paper is a wonderfully simple material. Lightweight, easy to shape and almost limitless in its applications, it is used by countless people each day, all over the world. Its practical, economical qualities have made it an essential part of modern life.

Behind it, however, is a complex industry that is as tough as it is specialized. You who work with pulp, paper and forest products place rigorous demands on your process equipment. And pumps are no exception.

Our many years of working with the pulp and paper industry have taught us the importance of reliable and efficient pumping solutions. Proof of this can be seen in the next generation of Scanpump process pumps, the BE series.

The BE series represents a total understanding of the needs of pulp and paper customers. It combines a deep knowledge of our customers' processes with the non-stop reliability that reduces operating expense. The BE series provides ample opportunities for process optimization, along with the lowest life cycle cost on today's market.

The following pages will introduce you to the BE series and its unique features. As you will see, BE pumps build on robust engineering and solid principles that guarantee performance in pulp and paper applications.



# PUMPS THAT LEAVE TO CHANCE.

The BE series is a single pump range designed specifically for the pulp and paper industry. Without compromises on coverage, reliability or service, pumps in the BE series are able to meet demanding customer needs in both general and special applications.

## Optimized performance coverage

Scanpump's knowledge of high-efficiency pump design has led to optimized performance coverage – a key strength of the BE series. An improved hydraulic design creates greater effectiveness in each individual pump, which enlarges the operating area around its point of best efficiency.

Each pump is thus used more flexibly, achieving process variations without compromising on high efficiency and operability. This creates great opportunities for pulp and paper producers, since it reduces power consumption and allows them to lower their energy costs. BE pumps are performance tested before dispatch according to tough international standards, which means that their high efficiencies can be guaranteed.

## Total reliability

Better performance coverage means high reliability, since the pumps operate under conditions which ensure their runnability. Wider areas of efficiency allow BE pumps to be selected more effectively, so that they experience less stress and vibration.

Reliability is pushed even further by the pumps' robust construction and integrated quality control. Sturdy components, such as the strong bearing assembly and the optimized impeller fixing, ensure reduced wear and lower maintenance costs.

All this combines to make the MTBF (Mean Time Between Failure) of BE pumps exceptional in the pulp and paper industry, where even a short production stop can mean tremendous losses.

## Simplified service

The BE series is as easy to work with as it is to trust. The pump design reduces maintenance, but also makes sure that any maintenance required is fast and simple to perform. Intelligent fittings and cartridge solutions facilitate insertion and removal.

Since the series is modular, there are also fewer parts to service and store. Technicians and operators need less training, and this means their time and skills can be optimized. With the BE series, a single, cost-effective range can handle many needs with minimum effort.

### BE pumps make no compromises on...

#### Range

- Optimized performance coverage.
- Wide operating area around point of best efficiency.

#### Reliability

- Effective pump selection for better runnability.
- Robust components and wear-resistant design.

#### Service

- Maintenance-reducing features.
- Modular construction with less to service and store.

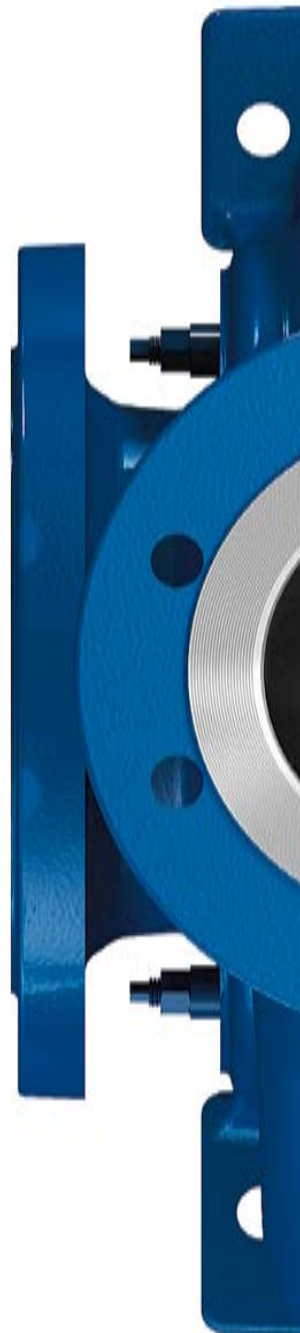

# NOTHING

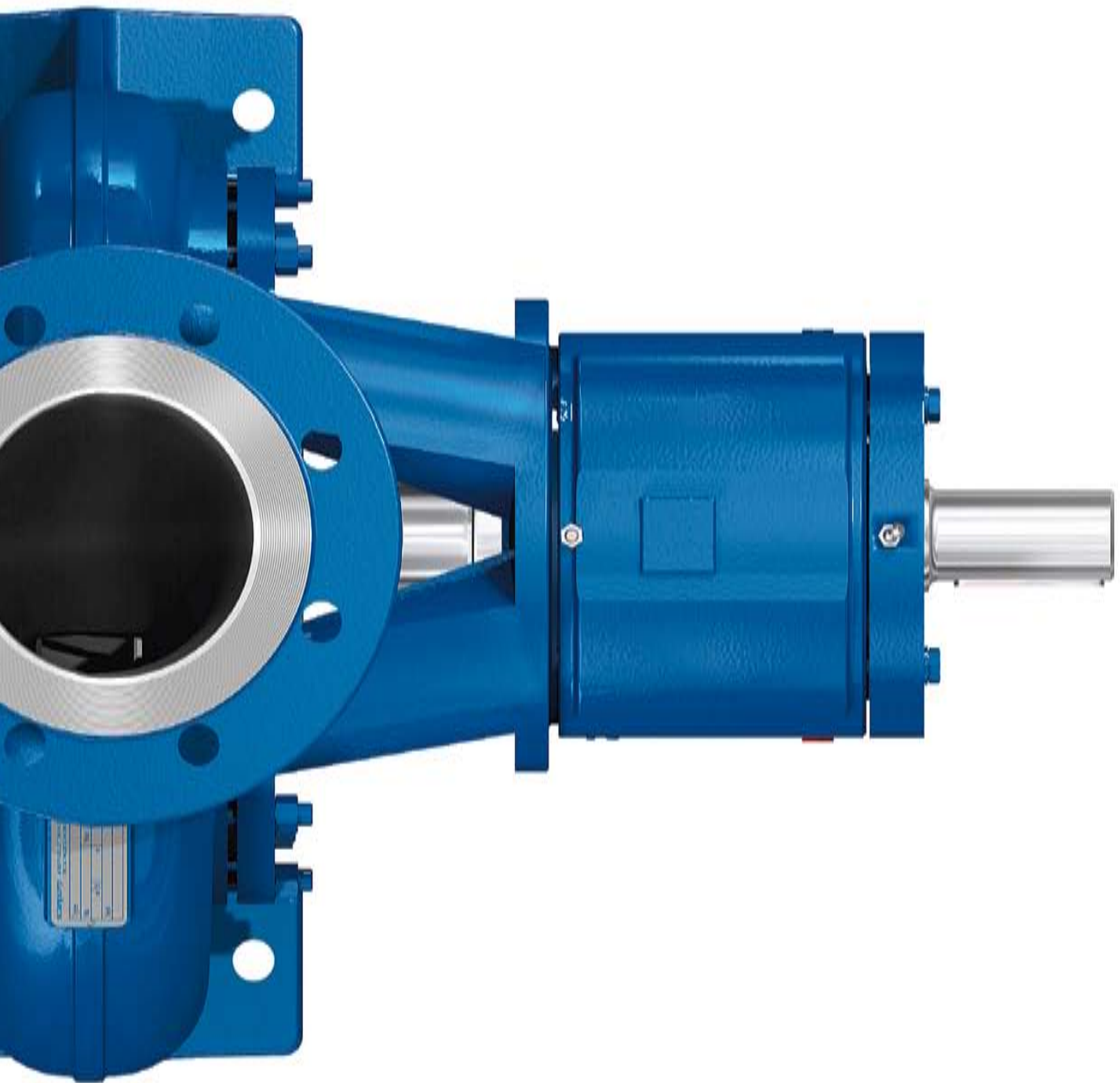

# THE IN'S AND OUT'S OF

Pumps in the BE series incorporate a wide range of performance-enhancing features. Their sturdy construction ensures reliability and a long pump lifetime, while their hydraulic design offers outstanding efficiencies.

## High wear resistance

Rugged BE pump construction creates long-term wear resistance. The generous wall thickness and the casing's smooth, pocket-free interior protect against erosion and corrosion.

## Secure impeller fixing

One impeller fixing serves for all material codes and pump sizes. The impeller can be easily fitted and removed for short MTTR (Mean Time To Repair).

A polygonal shaft secures the impeller fixing under all operating conditions, regardless of the direction of rotation. This ensures even power transmission, which results in stable operating conditions and long MTBF. A well designed o-ring shaft seal minimizes the risk of leakage.

## Optimized impeller design

The design of BE pump impellers raises efficiencies and lowers operating cost. The impellers can handle almost any suspensions and a huge range of slurries.

A new hydraulic design for semi-open impellers features large free passages. The sturdy construction ensures high wear resistance, resists corrosion and reduces sensitivity to foreign objects.

On vortex impellers, an improved vane design ensures clogless and trouble-free operation.

The robust construction minimizes the risk of shaft breakage in pumps used for tough applications.

## Adjustable wear disc

The replaceable wear discs protecting BE pump inlets have an improved seal against the casing and are easier to adjust. This means that high efficiencies can be retained as well as minimized MTTR. Their ATEX-approved (EU only) design offers safe, low-cost operation.

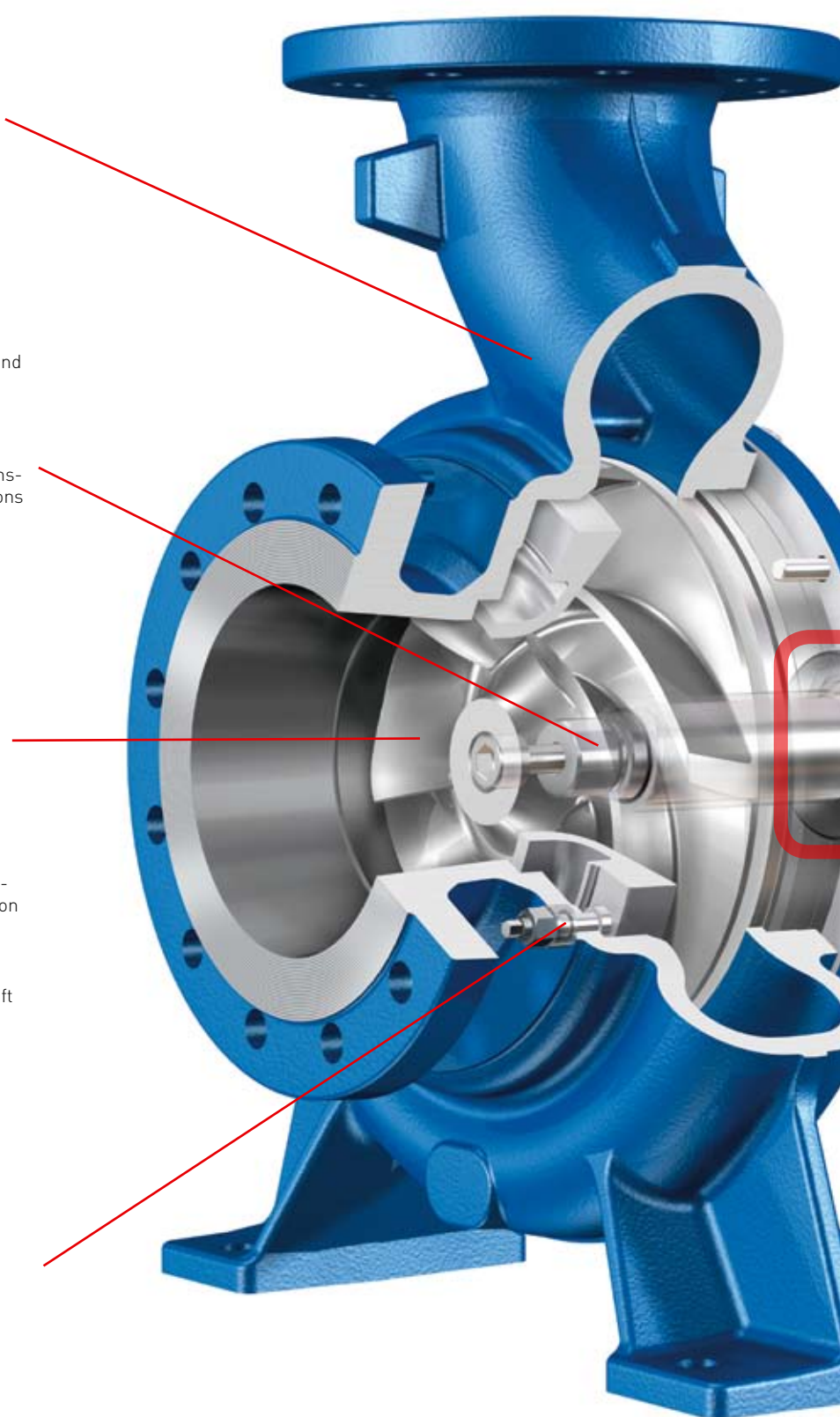

# OF DESIGN.

## Optimal seal

The System PSI sealing concept ensures the best conditions for the shaft seals. Alternatives include single and double mechanical seals, gland packing and dynamic seals, with a variety of materials to suit every application.

## Rugged bearing assembly

Bearings must withstand large axial thrust and radial loads simultaneously. BE pump bearing assemblies feature a sturdy design that ensures long MTBF, long pump lifetime and low maintenance costs. Six different bearing sizes cover all pumps in the series, and all bearings have angular contact ball bearings at the driven end.

Standard bearing assemblies are lubricated with grease, though oil is also an option. On oil-lubricated bearing assemblies, two inspection eyes are standard. This makes it easy to inspect the bearing assembly from both sides.

## Durable shaft

BE pump shafts are sturdy, with a deflection of less than 0.05 mm at the seal area under normal running conditions. This creates an excellent environment for the mechanical seal. All shafts are protected by a replaceable sleeve in stainless steel or higher quality alloys.

## Impeller types

BE pumps are available with semi-open impellers. For some sizes and applications, ESDF and vortex impellers can also be selected.



For stock applications, semi-open impellers are normally used. Here, a 6-vane impeller.



For stock applications with solids, semi-open impellers with a reduced number of vanes are normally used. Here, a 3-vane impeller.



For head boxes, special low-pulsation impellers are used. In end suction pumps, these are of ESDF (End Suction Double Flow) type.



For passage of the largest solids or sensitive pulp suspensions, vortex impellers are used.

# SMART THINKING, SO

BE pumps are built according to a two-part philosophy of design integration. One of the components is System PSI, or Pump Seal Integration. The other is System PMI, or Pump Mill Integration. Both provide unique advantages that ensure maximum reliability at a lower cost.

## System PSI

System PSI is a total concept, based upon the knowledge of how to keep a pump operating as long as possible and with minimum pump downtime. The system is built on a combination of strong bearing assemblies and optimum sealing technology.

A pump's shaft seal is its Achilles' heel, and problems with it cause the majority of pump failures within the process industry. However, close co-operation with our customers has given us a thorough understanding of shaft seal operating conditions. By integrating the seal arrangement into the pump design, ideal seal operating conditions and high reliability are created.



Available in six sizes, the PSI cartridge can be fitted with any DIN-mounted single mechanical seal, regardless of supplier. Here, a rubber bellows seal of RBB type.



Our dynamic seal, Masterseal, is specially designed for pulp and paper stock, slurries and other demanding applications.

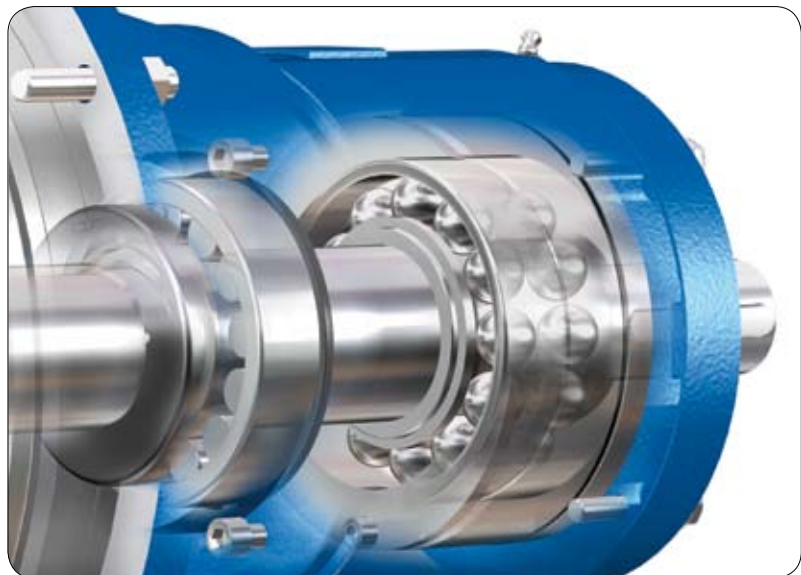

### Reliability.

Sturdy design on all bearing assemblies minimizes shaft deflection and ensures a long seal life. The robust construction also minimizes vibration.

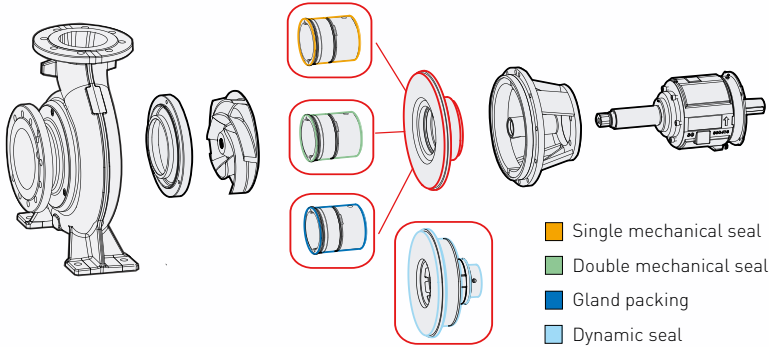

- Single mechanical seal
- Double mechanical seal
- Gland packing
- Dynamic seal

**Versatility.** Our design lets you be flexible in your sealing choice. When changing from a gland packing to a mechanical seal, only the seal cartridge has to be changed.



# SOLID ASSURANCE.

## System PMI

System PMI is a well-designed modular concept featuring concrete baseplates for free-standing (floating) installations. A lifting arm and a modular fitting system for motors are also part of the concept.

With System PMI there is no need to plan and supervise the grouting in of pumps. No grouting is necessary, which means the total cost of installation work is reduced. This can mean considerable savings, both for turnkey suppliers and for mills undergoing rebuilds.

## Many advantages with System PMI

- Reduced downtime thanks to better alignment.
- Elimination of piping stresses.
- Reduced cost for installation work.
- Shorter project time.
- A range of options to flexibly suit installation demands.
- Minimal cost for moving or upgrading the pump.
- Elimination of shell sound transmitted in buildings.
- Ability to easily change motor size.
- Future flexibility, as it is easy to move the pump during rebuilds.

To suit varying engineering demands, different installation options are available. Here a concrete baseplate with levelling pads.

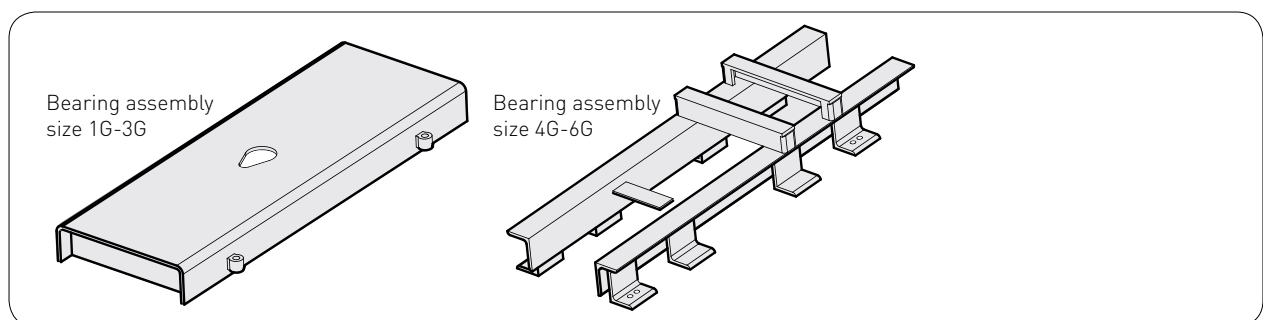
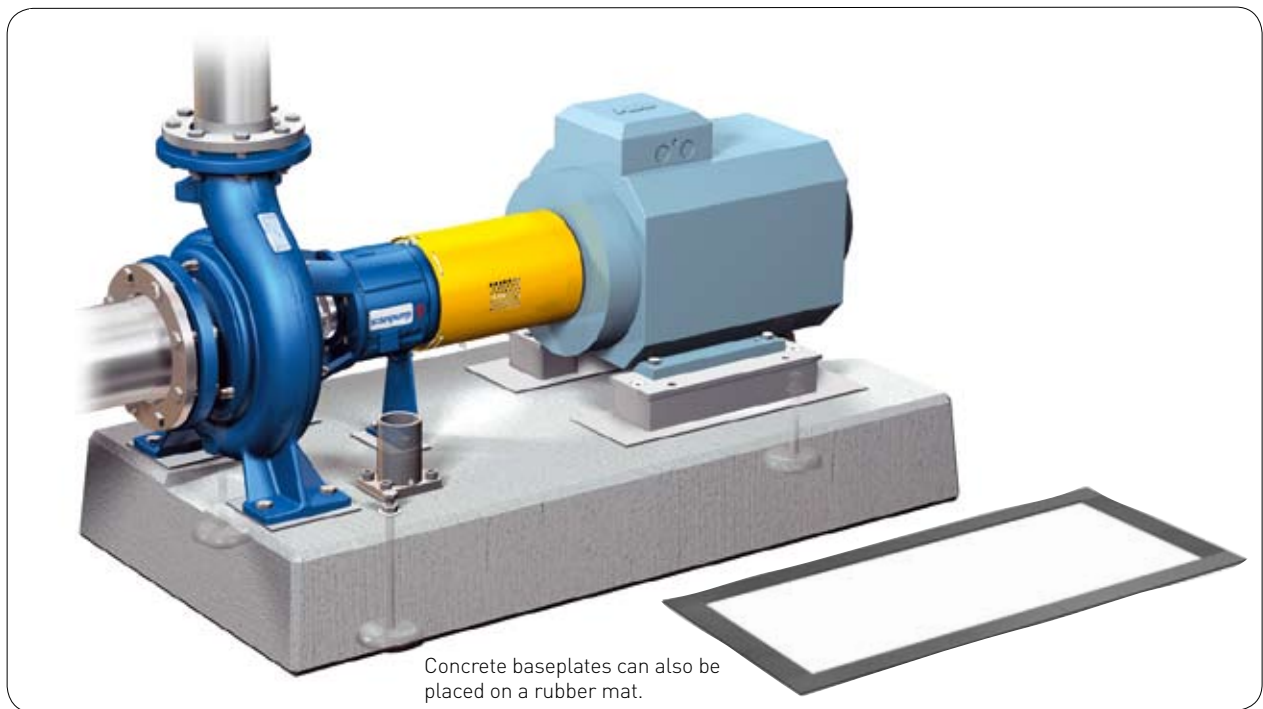

Steel baseplates and baseframes are also available.

The BE series provides a flexibility no other range of pumps can match. Through modular construction, BE pumps can be suited to almost any pulp and paper application, yet they comprise a minimum number of parts.

Though the entire BE series includes 39 individual pumps, the actual number of bearing assemblies, seal cartridges, lanterns and casing covers is significantly smaller. The series' modular parts can be interchanged to meet the exact specifications for a particular pump.

For the customer, this creates great advantages. Only a minimum range of parts must be kept on hand, which reduces costs and optimizes the use

of storage space. Downtime is also reduced, since bearing assemblies and seal cartridges can rapidly be exchanged with pre-assembled units from stock.

Perhaps the greatest advantage, however, is the fact that there is less to learn. Service technicians and operators can receive training on a single series with a minimum number of parts, after which they can handle process pumps for a complete range of applications.

Through high interchangeability, simplified service and a low number of spare parts, our modular system results in lower maintenance costs.

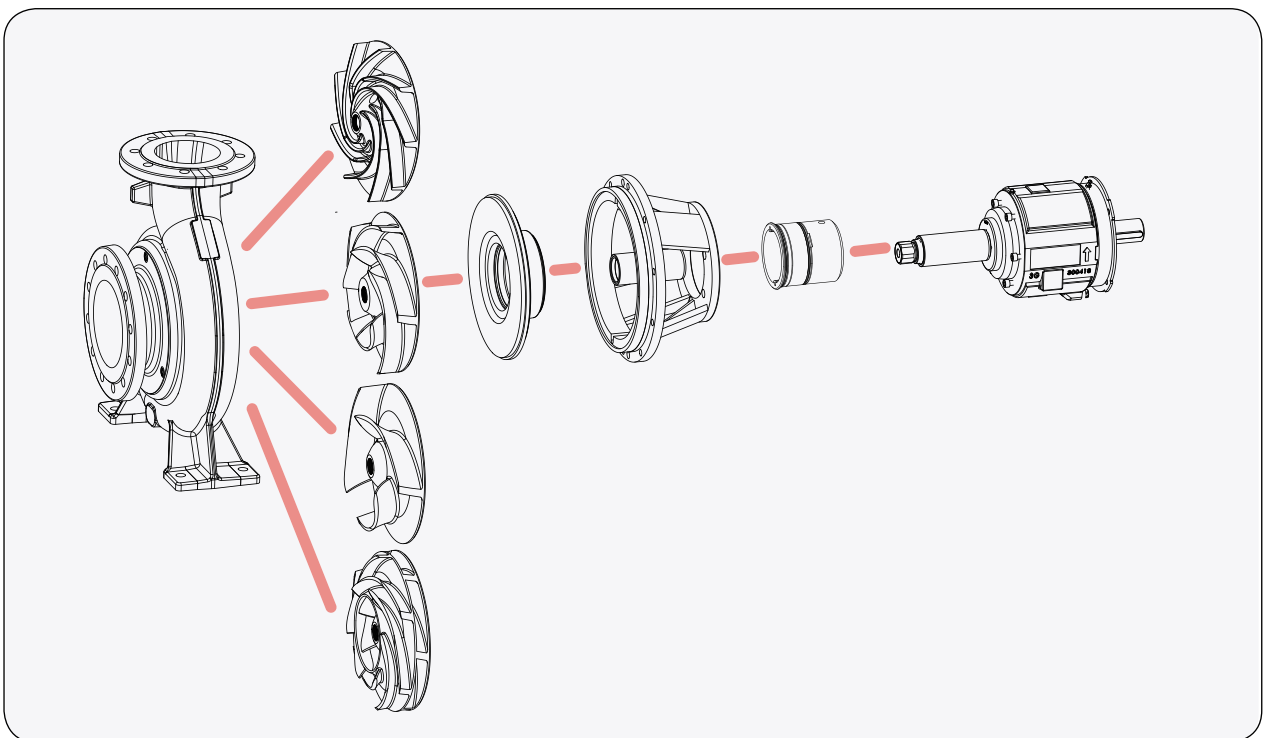



**THE MAXIMUM  
MINIMUM.**

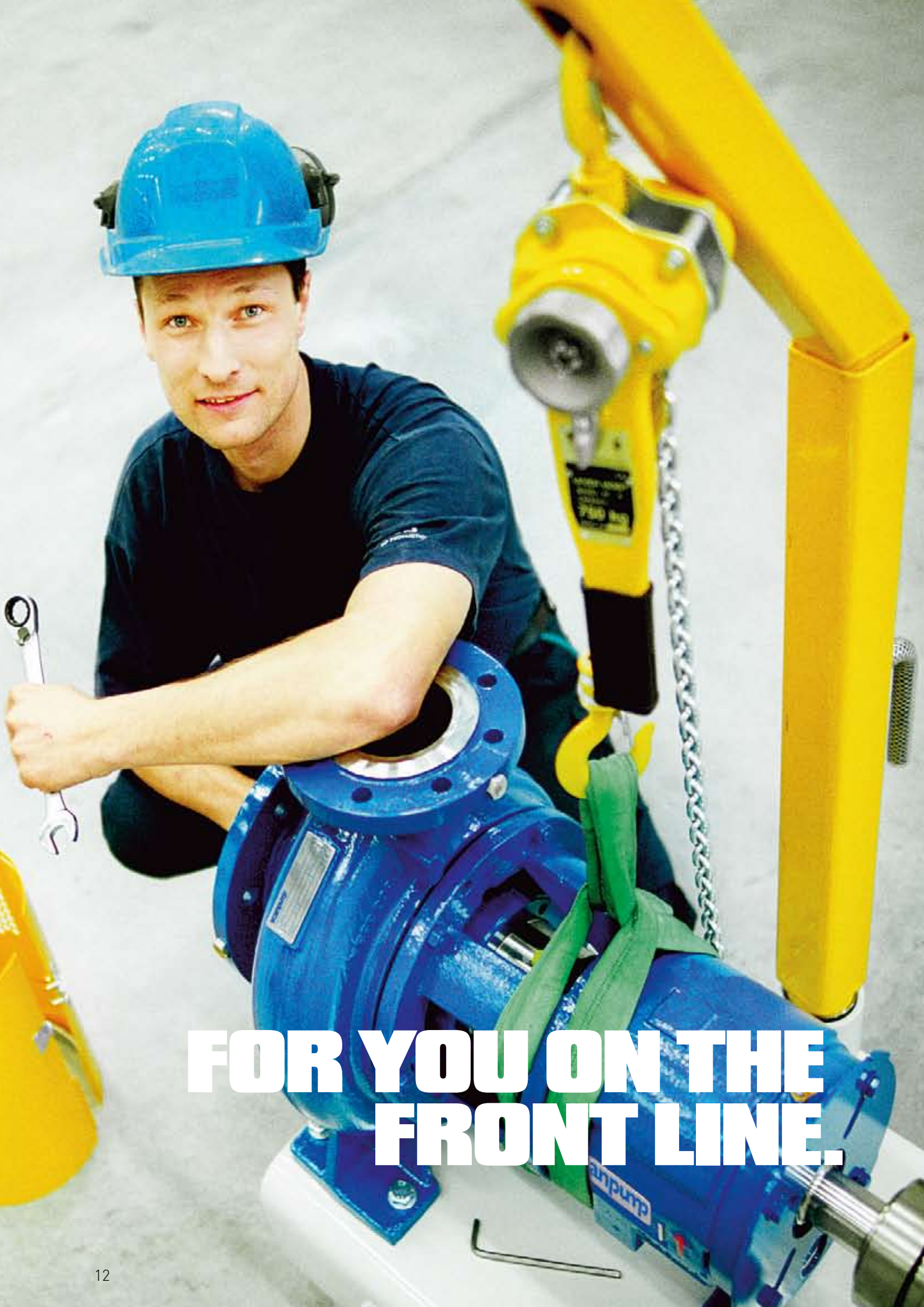

**FOR YOU ON THE  
FRONT LINE.**

BE pumps are intended for long, tough and continuous operation. The bearing assemblies can go long intervals between lubrications, and the pumps as whole are designed for minimum maintenance. Modular design makes it simple to replace the bearing assembly and shaft seal, and service kits with genuine OEM parts are available for bearing assemblies, impellers and wear discs.

#### **Convenient spacer coupling (back pull-out)**

BE pumps are normally fitted with spacer couplings, which allow the rotor assembly to be pulled from the back of the pump casing without moving the motor. This guarantees fast and simple maintenance.

We also offer a special lifting arm and pulley block, which allow one person to safely and easily remove and refit the rotor units in pumps with large bearing assemblies.

#### **Pre-assembled seal cartridge**

Mechanical seals demand knowledge and skill for proper installation. BE pumps use a pre-assembled seal cartridge, which makes the process far less complex. The cartridge's few parts make it quick and easy to install, and the seal is perfectly mounted every time.

We also provide tools that further simplify service, shorten downtime and reduce the risk of material damage.

#### **Windowed coupling guards**

The coupling guards of BE pumps feature an inspection window as standard. This allows easy stroboscope inspection of the couplings' condition during operation.

#### **Improved impeller fixing**

With the BE pump impeller fixing, the impeller can easily be fitted and removed for short MTTR. The simplified dismantling and fitting are the result of fewer parts and wider impeller tolerances.

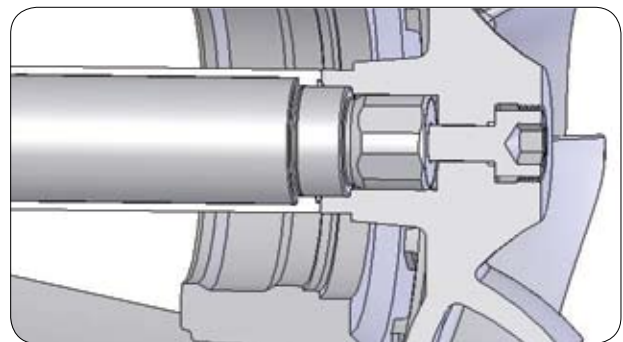

Improved impeller fixing.

#### **Easy wear disc adjustment or replacement**

The wear disc can be easily adjusted from the pump casing's front without affecting the seal position. This makes it easy to maintain high efficiency over the entire lifetime of the pump. The o-rings can be easily exchanged without dismantling the pump.

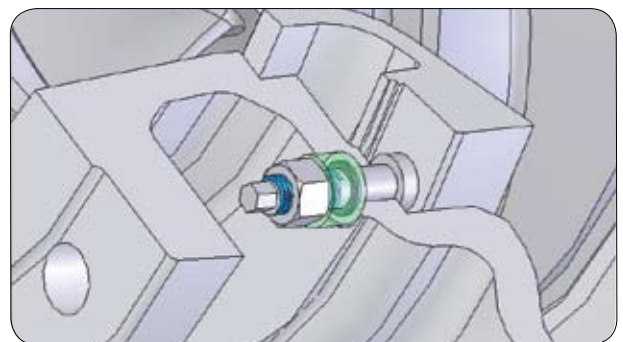

# Technical data

Properties	
Capacity	20-6500 m <sup>3</sup> /h / 90-28700USgpm
Head	5-160 m / 16-527 feet
Temperature	Max.190°C / 375°F (with grease lubrication)
Pressure Rating	PN6/PN10/PN16
Flanges	Acc. to ISO 7005 PN10-PN16 (BS 4504-ANSI 150-JIS 10K-16K)
Lubrication	Grease; oil as option
Specification	ISO 5199 "Technical Specification for centrifugal pumps class II"
Dimension	For applicable sizes acc. to ISO 2858 except "g" dimension. Flange size 125 is also replaced by size 150.
BE pumps are performance tested before dispatch according to ISO 9906, Grade 2 as standard.	

### Installation alternatives

**Horizontal installation**

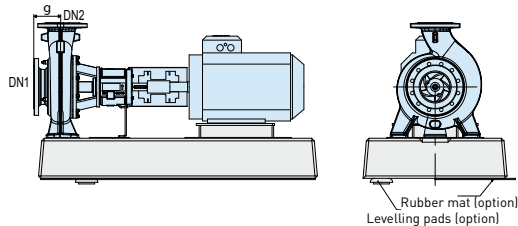

**Close-coupled installation**

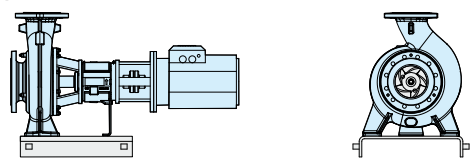

**Vertical installation**

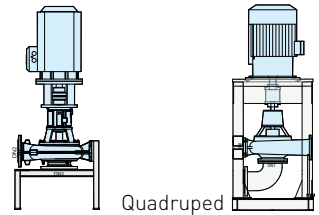

Four-legged stand      Quadruped

Rubber mat (option)  
Levelling pads (option)

# Materials

Standard material combinations	Code											
	03	05	24	08	09	21	23	25	26	27	32	
Pump casing	Cast iron Gr. 200	Cast iron Gr. 200	Stainless steel 2324*)	Nodular iron Gr. 400-18	Nodular iron Gr. 400-18	Stainless steel 2399	Stainless steel 2324*)	Stainless steel 1.4517	Stainless steel 1.4408	Stainless steel 1.4527	Nickel alloy S6371	
Wear disc	Cast iron Gr. 200	Stainless steel 2324*)	Stainless steel 2324*)	Cast iron Gr. 200	Stainless steel 2324*)	Stainless steel 2399	Stainless steel 2399	Stainless steel 1.4517	Stainless steel 1.4408	Stainless steel 1.4527	Nickel alloy S6371	
Impeller	Stainless steel 2324*)	Stainless steel 2324*)	Stainless steel 2324*)	Stainless steel 2324*)	Stainless steel 2324*)	Stainless steel 2399	Stainless steel 2399	Stainless steel 1.4517	Stainless steel 1.4408	Stainless steel 1.4527	Nickel alloy S6371	
Shaft	Stainless steel 2324*)	Stainless steel 2324*)	Stainless steel 2324*)	Stainless steel 2324*)	Stainless steel 2324*)	Stainless steel 2324*)	Stainless steel 2324*)	Stainless steel 2324*)	Stainless steel 2324*)	Stainless steel 2324*)	Stainless steel 2324*)	
Shaft sleeve	Stainless steel 2324*)	Stainless steel 2324*)	Stainless steel 2324*)	Stainless steel 2324*)	Stainless steel 2324*)	Stainless steel 2324*)	Stainless steel 2324*)	Stainless steel 1.4539	Stainless steel 2324*)	Stainless steel 1.4539	Nickel alloy S6371	
*) Duplex stainless steel.												

Materials	Equivalent grades			Germany	UK	USA	Chemical composition
	EN	France					
Gr. 200	Grade 200	Ft20D		GG20	Gr. 220	A45/30B	Cast iron
Gr. 400-18	Grade 400-18	FGS 400-12		GGG-40	Gr. 420/12	A536/60-40-18	Nodular iron
2324	1.4460	-		1.4460	-	AISI 329	24Cr 5Ni 1.5Mo 0.10C
2399	-	-		-	-	-	32Cr 5Ni 1.6Si 1.3C
S6371	-	-		2.4537	-	A494/CW-12MW	16.5Cr 56Ni 17Mo 4.5 W 6Fe
1.4408	1.4408	Z6CND 18-12-M		1.4408	316 C16	A743/CF-8M	19Cr 11Ni 2Mo 0.07C
1.4517	1.4517	Z3 CNUD 26.5-M		-	-	A743/CD-4 M Cu	25 Cr 6Ni 3Mo 3Cu 0.03C
1.4527	1.4527	Z6NCDU 25-20-04M		-	332 C11	A743/CN-7 M	20Cr 30Ni 4Mo 3.5 Cu 0.06C
1.4539	1.4539	Z2 NCDU 25.20		1.4539	-	UNSN 08904	20Cr 25Ni 4.5Mo 1.5 Cu 0.02C

# Performance curves

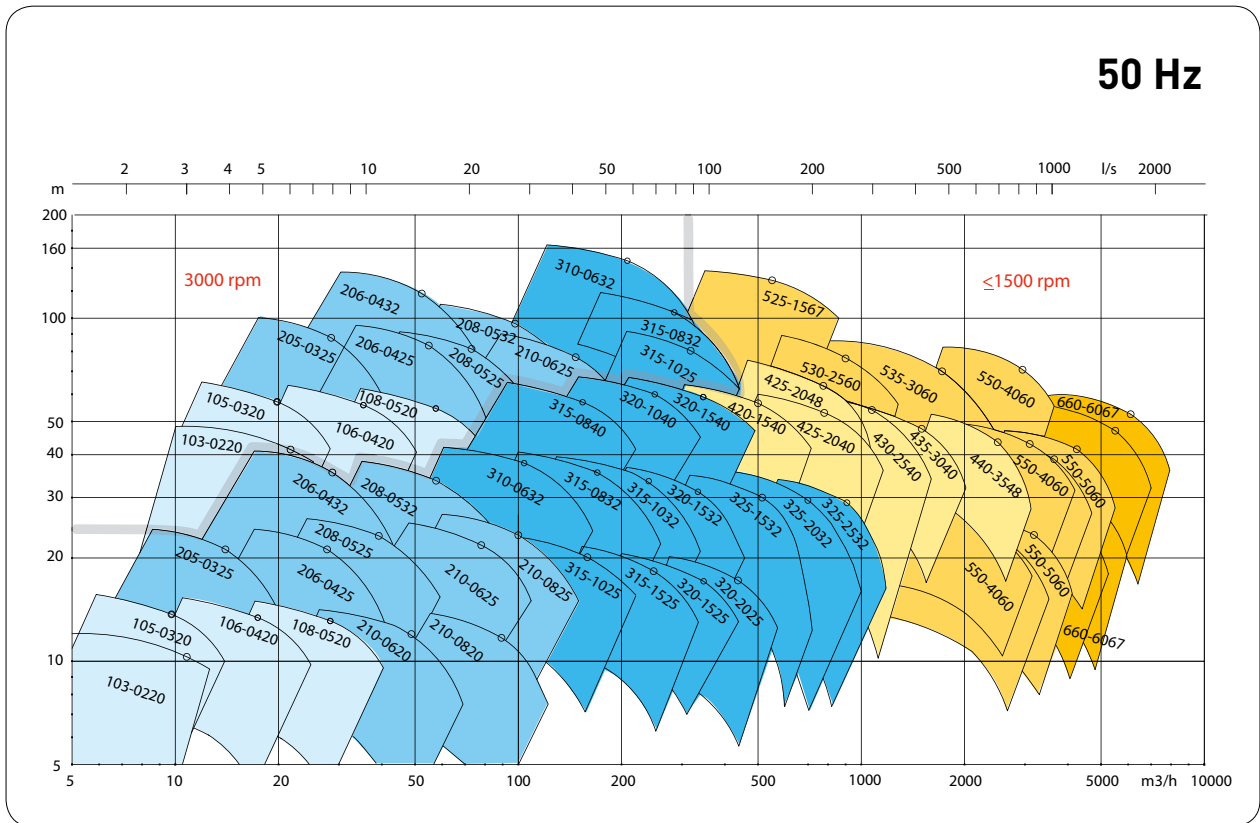

Bearing assembly sizes

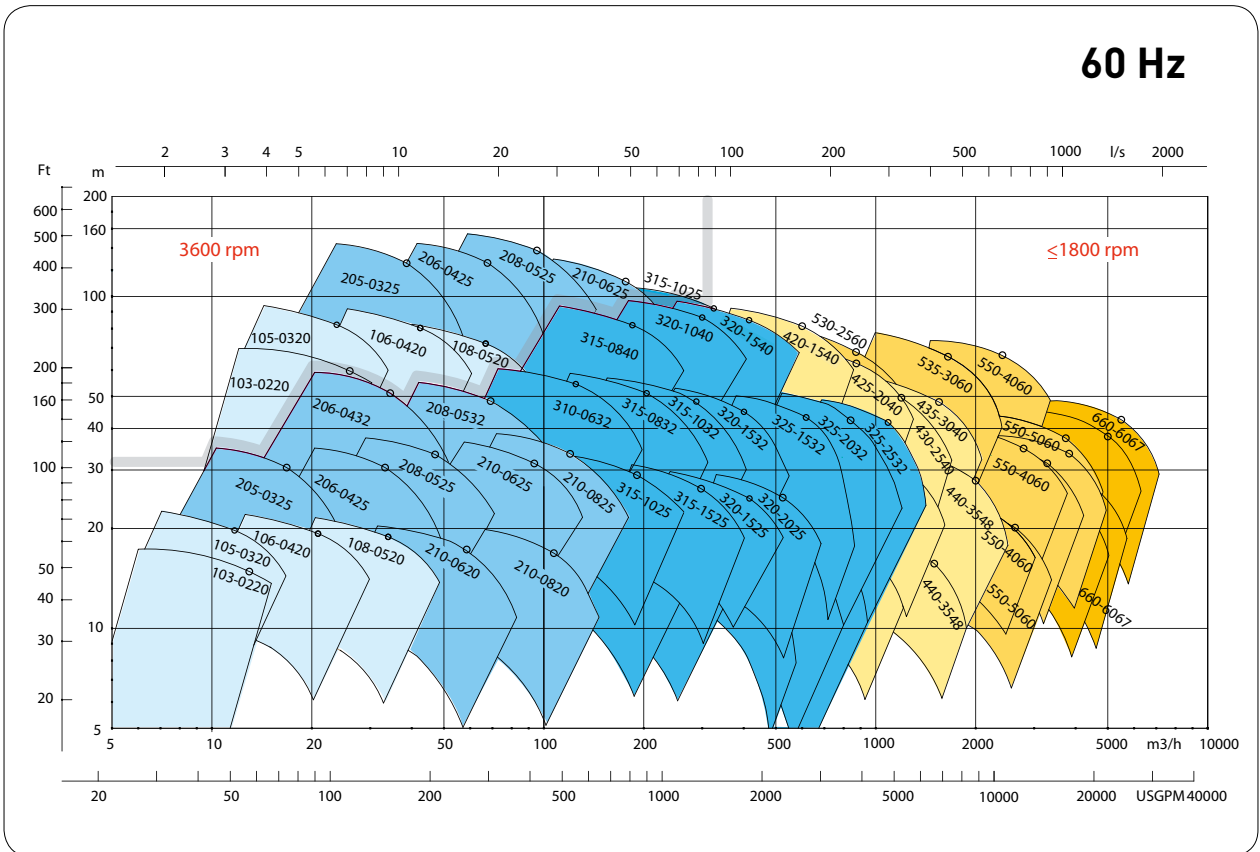



Scanpump is the pulp and paper specialist within the Cardo Group. Our organization has a total focus on the pulp and paper industry, yet we are able to draw on extensive ABS experience with all types of pumps, agitators and aerators.

Our coordinated local presence and dedicated central resources make us a flexible, full-service partner in pulp and paper.

<p><b>Head office</b>          Sweden          Scanpump AB          Tel. +46 31 83 63 00          Fax +46 31 16 79 14          info@scanpump.com          www.scanpump.com</p>	<p><b>Subsidiaries</b>          Denmark          Scanpump A/S          Tel. +45 48 17 11 10          Fax +45 48 17 19 11          info@scanpump.com          www.scanpump.com</p>	<p>France          Scanpump AB          Tel. +33 4 72 31 00 06          Fax +33 4 78 05 57 74          info@scanpump.com          www.scanpump.com</p>	<p>Germany          Scanpump AB          Tel. +49 6257 9317 0          Fax +49 6257 9317 99          info@scanpump.com          www.scanpump.com</p>	<p>Great Britain          Scanpump AB          Tel. +44 1293 744 836          Fax +44 1293 543 392          info@scanpump.com          www.scanpump.com</p>	<p>The Netherlands          Scanpump AB          Tel. +31 651 08 21 25          Fax +31 523 27 04 71          info@scanpump.com          www.scanpump.com</p>	
<b>Subsidiaries, ABS Group</b>						
<p>Austria          Tel. +43 2236 642 61          Fax +43 2236 642 66          www.absgroup.com</p>	<p>Finland          Tel. +358 7 5324 0300          Fax +358 9 55 80 53          www.absgroup.com</p>	<p>Norway          Tel. +47 67 55 47 00          Fax +47 67 55 47 50          www.absgroup.com</p>	<p>South and North America</p>			<p>USA          Tel. +1 203 238 2700          Fax +1 203 238 0738          www.absgroup.com</p>
<p>Asia Pacific          Singapore          Tel. +65 6463 3933          Fax +65 6462 2122          www.absgroup.com</p>	<p>China          Tel. +86 21 68882900          Fax +86 21 58826708          www.absgroup.com</p>	<p>Brazil          Tel. +55 41 2108-8100          Fax +55 41 3348 1879          www.absgroup.com</p>				

