



CLT & CLB - CURVE BOOK

CHEMICAL PROCESS PUMPS





WE HAVE ALL THE TICKS

- FOUNDED IN 1932**
- LEADING PROVIDER OF TOP QUALITY PRODUCTS**
- LOCAL MANUFACTURE**
- ACCREDITED PUMP REPAIR/SERVICE WORKSHOP**
- TAILOR MADE PUMPING SOLUTIONS**
- STATE OF ART TRAINING CENTRE**
- CBS: QUALITY MANAGEMENT SYSTEM**
- BEE ACCREDITED**
- DEEP APPLICATION KNOWLEDGE**



Version 1 - Chemical Process Pumps Curve Book: Rapid Allweiler Pumps

Whilst all care has been taken to ensure the accuracy of the information contained in this Brochure was correct at the time of printing, please be advised we cannot be held responsible for any errors contained within and or changes that may have taken place. Dimensions contained within are for reference purpose only and should not be used for construction; certified drawings are available upon request. For confirmation of any information contained herewith please contact a member of our technical sales team.

COLFAX
Fluid Handling

ALLWEILER 

TOMBSTONE CURVES

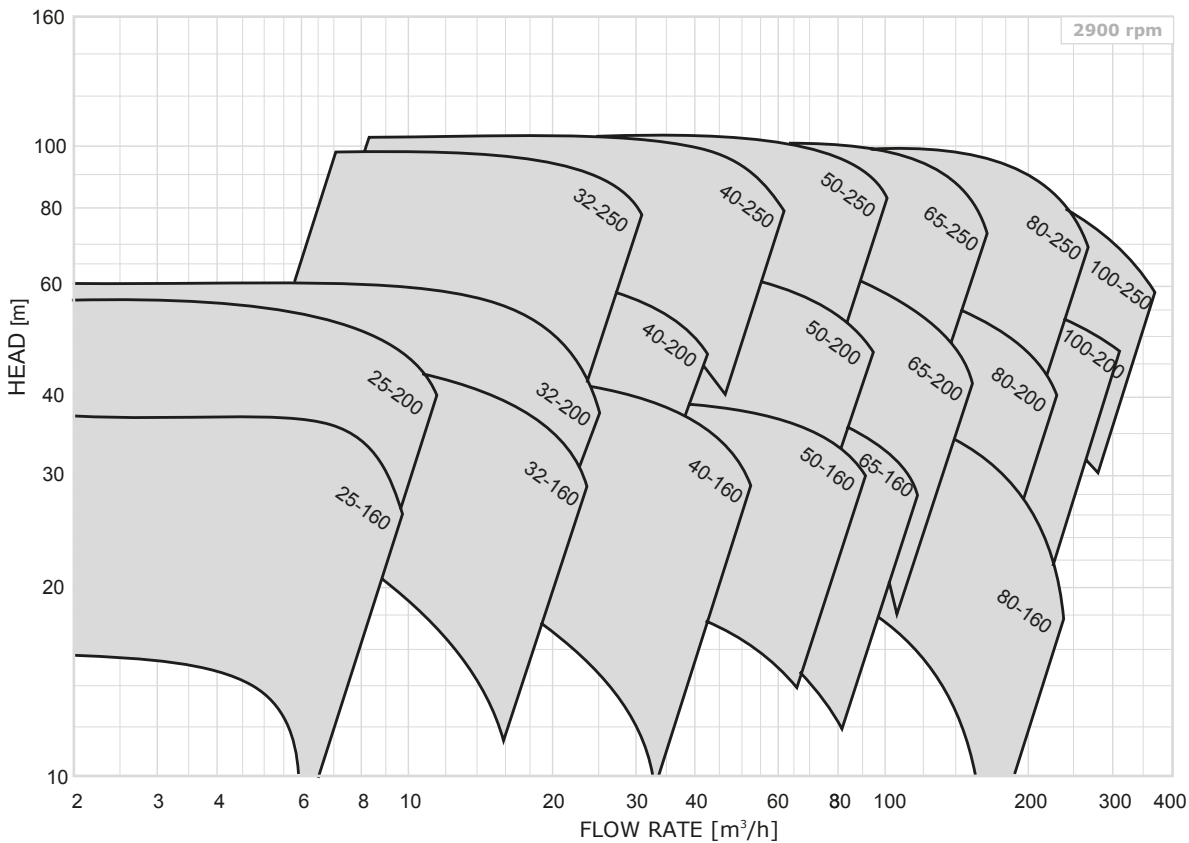
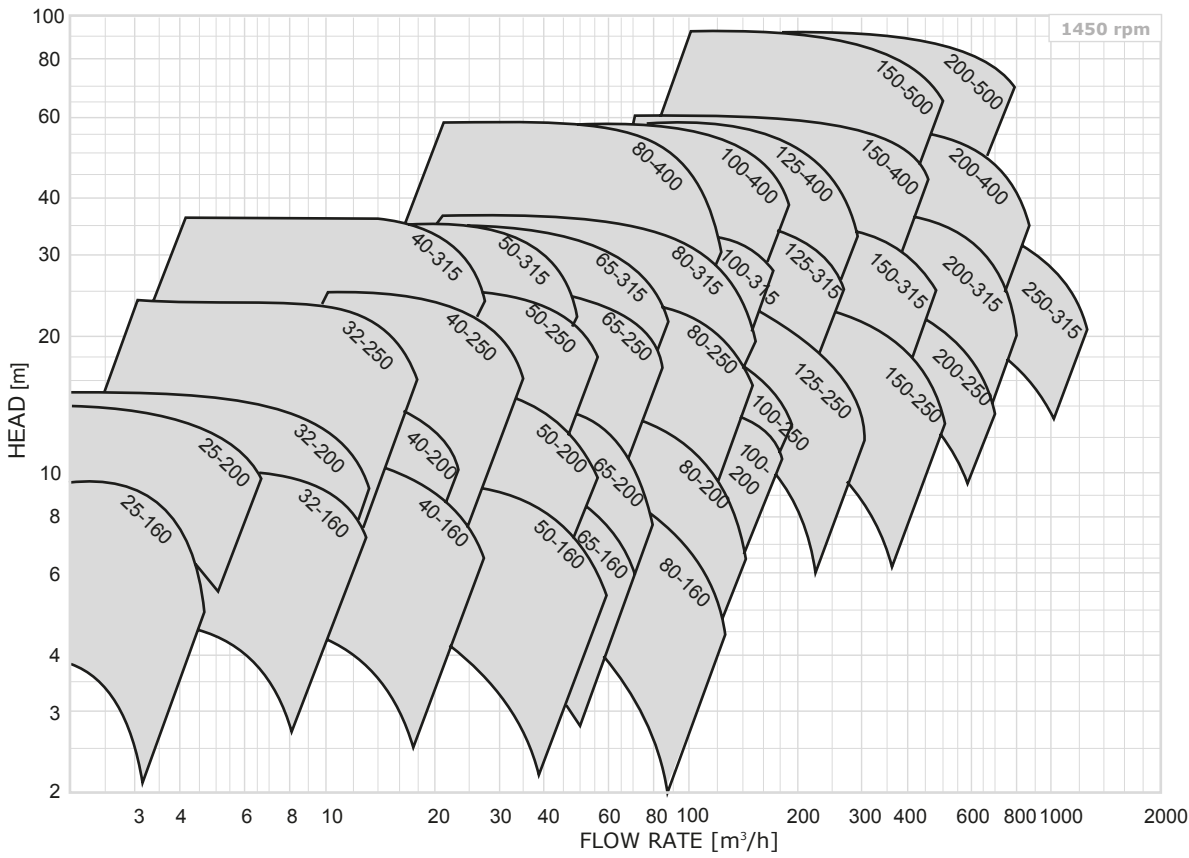

Size*	Pg. no.	
	1450	2900
25-160	3	42
25-200	4	43
32-160	5	44
32-200	6	45
32-250	7	46
40-160	8	47
40-200	9	48
40-250	10	49
40-315	11	50
50-160	12	51
50-200	13	52
50-250	14	53
50-315	15	54
65-160	16	55
65-200	17	56
65-250	18	57
65-315	19	58
80-160	20	59
80-200	21	60
80-250	22	61
80-315	23	62
80-400	24	
100-200	25	63
100-250	26	64
100-315	27	65
100-400	28	
125-250	29	
125-315	30	
125-400	31	
150-250	32	
150-315	33	
150-400	34	
150-500	35	
200-250	36	
200-315	37	
200-400	38	
200-500	39	
250-315	40	
250-400	41	

TOMBSTONE CURVES

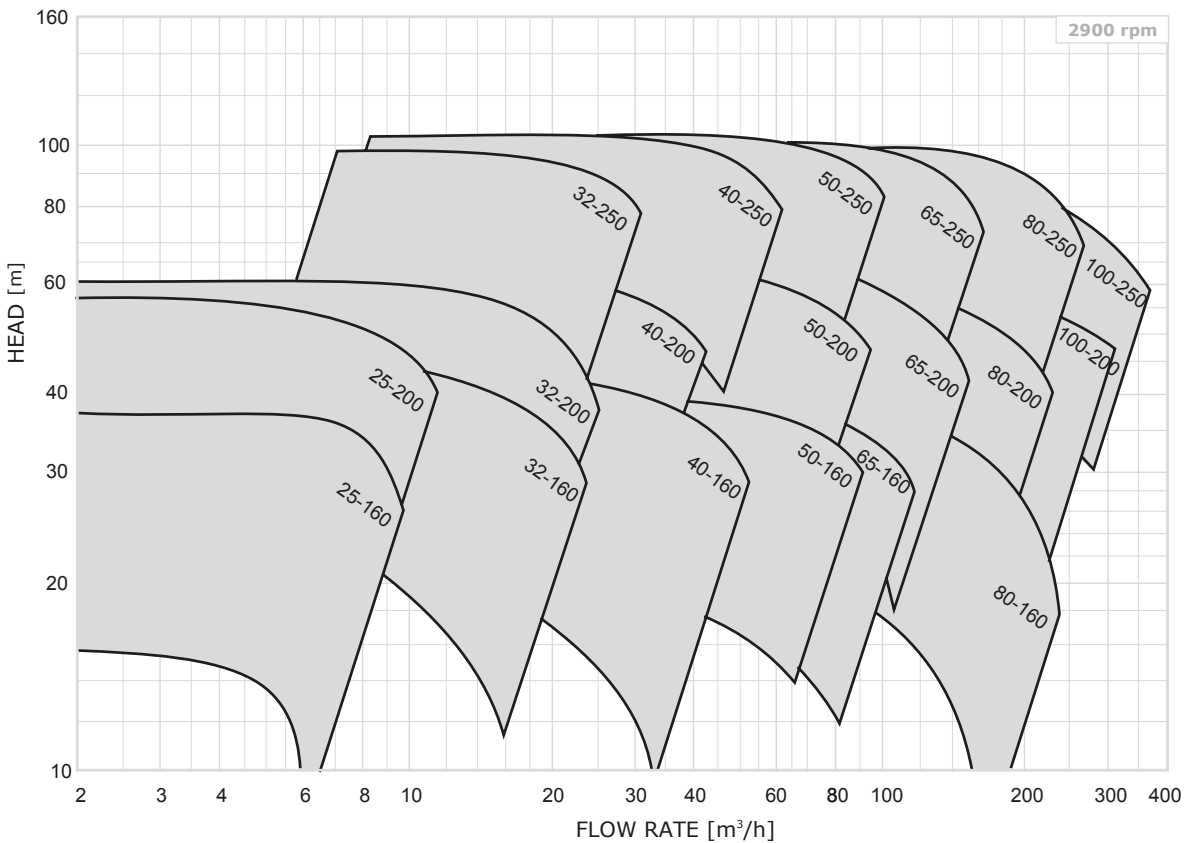
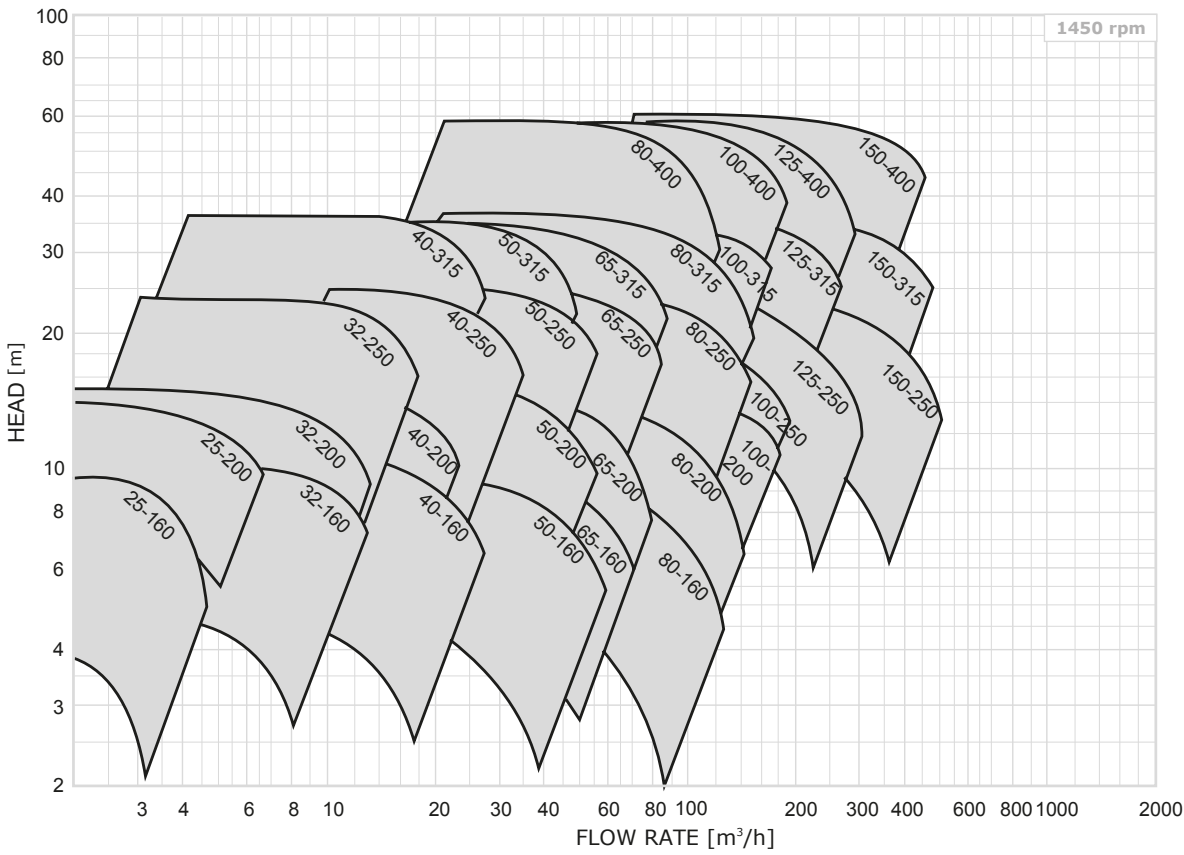

Size*	Pg. no.	
	1450	2900
25-160	3	42
25-200	4	43
32-160	5	44
32-200	6	45
32-250	7	46
40-160	8	47
40-200	9	48
40-250	10	49
40-315	11	50
50-160	12	51
50-200	13	52
50-250	14	53
50-315	15	54
65-160	16	55
65-200	17	56
65-250	18	57
65-315	19	58
80-160	20	59
80-200	21	60
80-250	22	61
80-315	23	62
80-400	24	
100-200	25	63
100-250	26	64
100-315	27	65
100-400	28	
125-250	29	
125-315	30	
125-400	31	
150-250	32	
150-315	33	
150-400	34	
150-500	35	
200-250	36	
200-315	37	
200-400	38	
200-500	39	
250-315	40	
250-400	41	

CLT & CLB

MEDIUM-DUTY CENTRIFUGAL CHEMICAL PUMPS TO EN 733 (DIN 24256)



CHARACTERISTIC CURVE

Issue Date
OCTOBER 2005

Suction Diameter
25mm

Discharge Diameter
40mm

DIN 24 256
CLT 25-160

Based on water density 1000 kg/m³ and viscosity 1 cSt.
Head, capacity and efficiency according to ISO Standard 2548: 1973 Annex B

1450 rpm

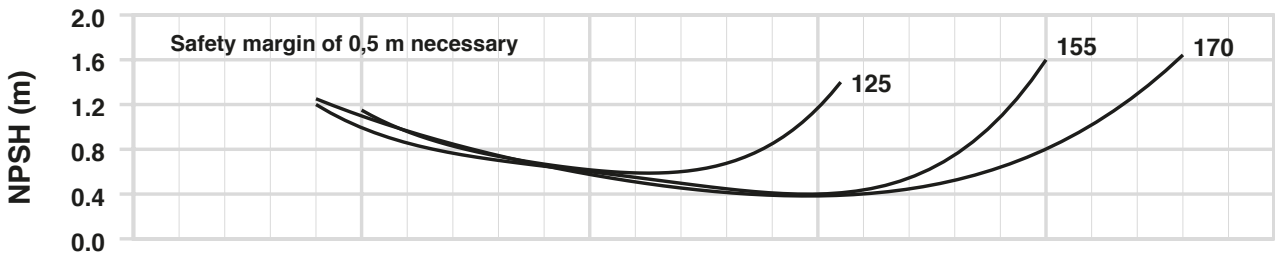
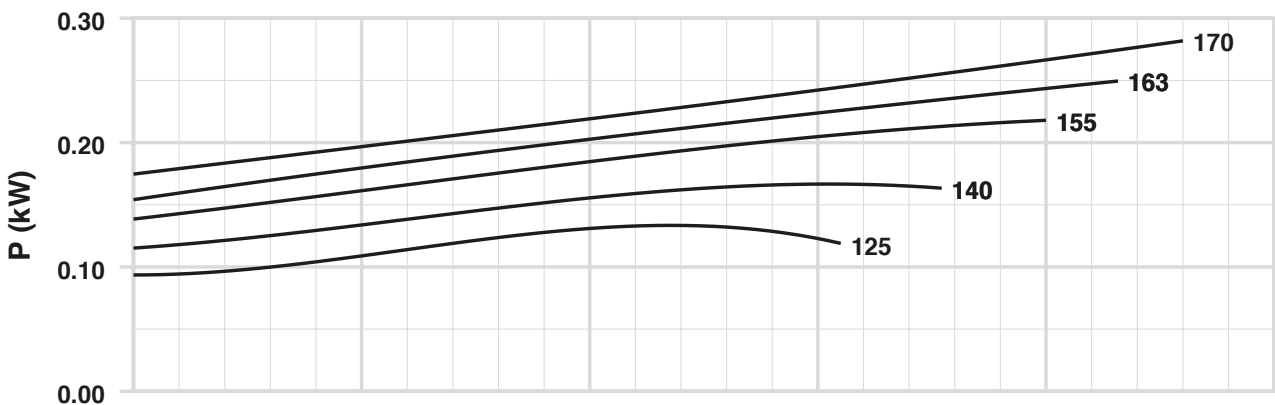
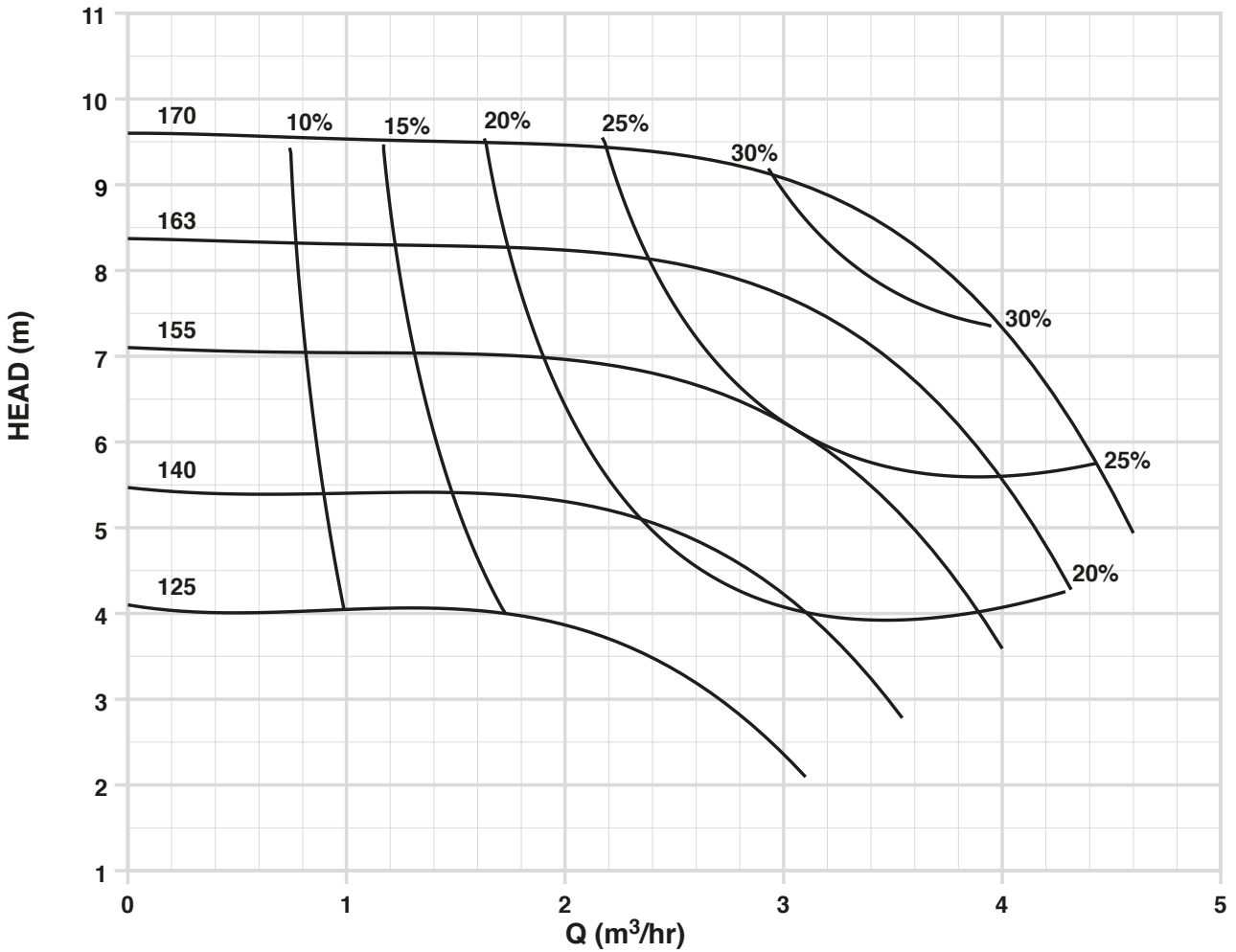

1450

CLT & CLB

MEDIUM-DUTY CENTRIFUGAL CHEMICAL PUMPS TO EN 733 (DIN 24256)



CHARACTERISTIC CURVE

DIN 24 256
CLT 25- 200

Issue Date
OCTOBER 2005

Suction Diameter
40mm

Discharge Diameter
25mm

Based on water density 1000 kg/m³ and viscosity 1 cSt.
Head, capacity and efficiency according to ISO Standard 2548: 1973 Annex B

1450 rpm

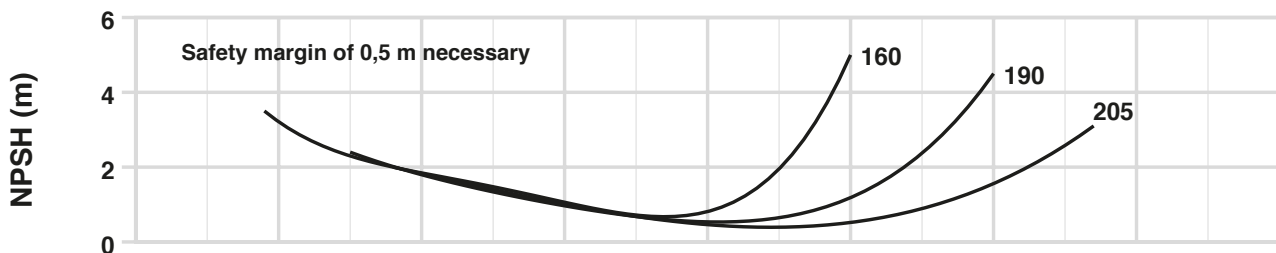
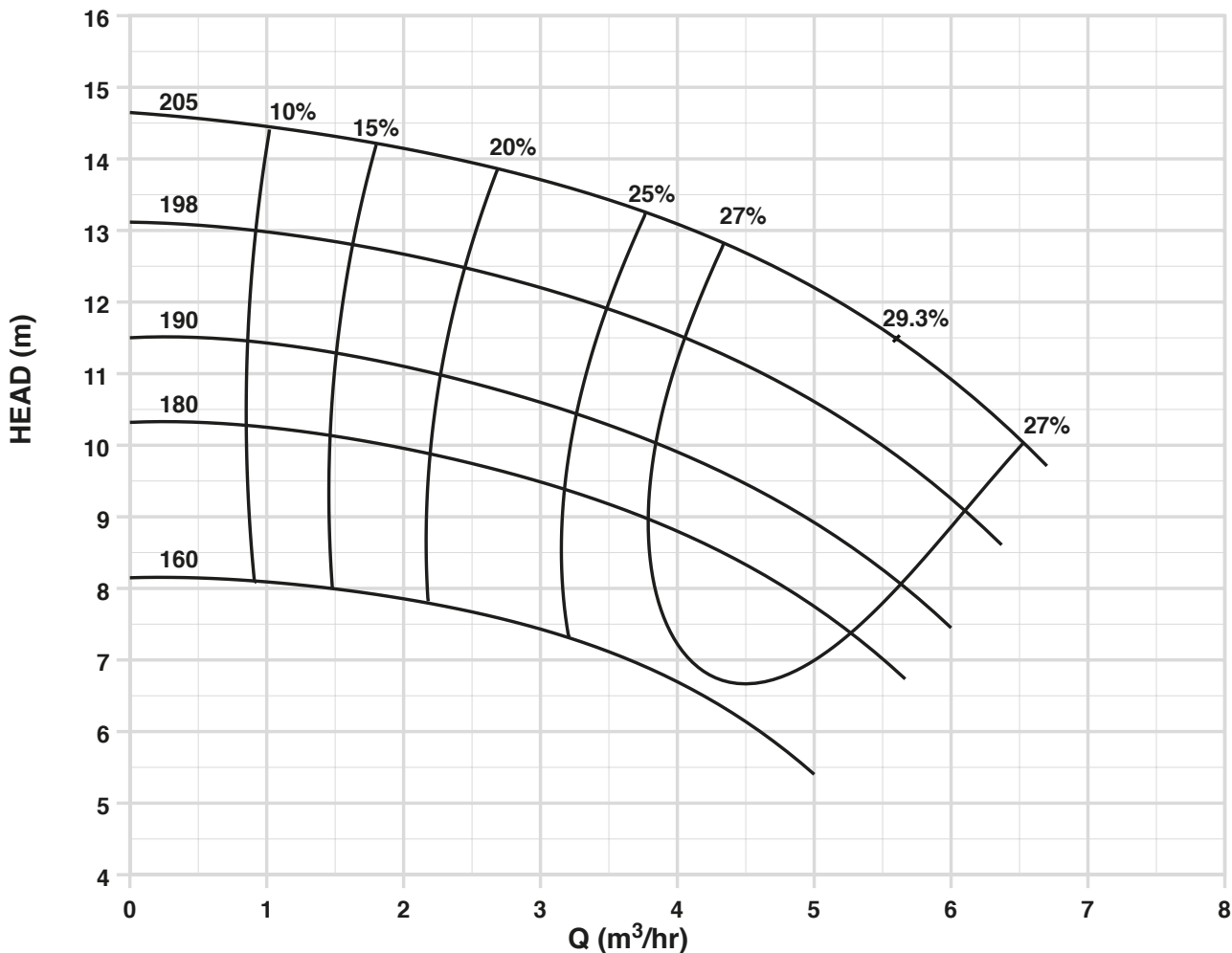

1450

CLT & CLB

MEDIUM-DUTY CENTRIFUGAL CHEMICAL PUMPS TO EN 733 (DIN 24256)



CHARACTERISTIC CURVE

Issue Date
OCTOBER 2005

Suction Diameter
50mm

Discharge Diameter
32mm

DIN 24 256
CLT 32- 160

Based on water density 1000 kg/m³ and viscosity 1 cSt.
Head, capacity and efficiency according to ISO Standard 2548: 1973 Annex B

1450 rpm

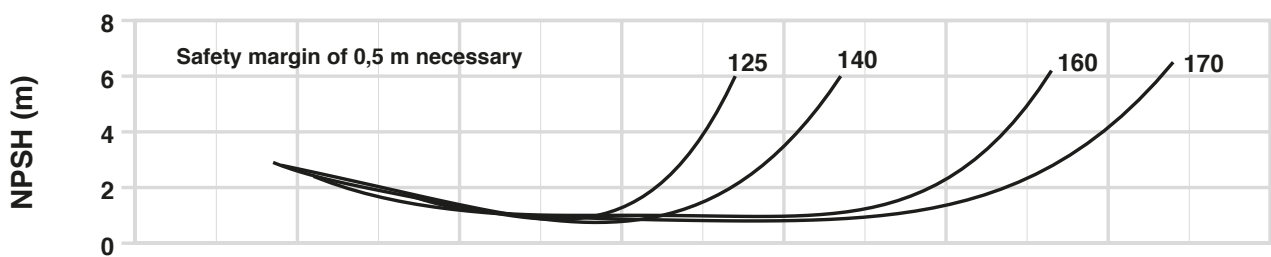
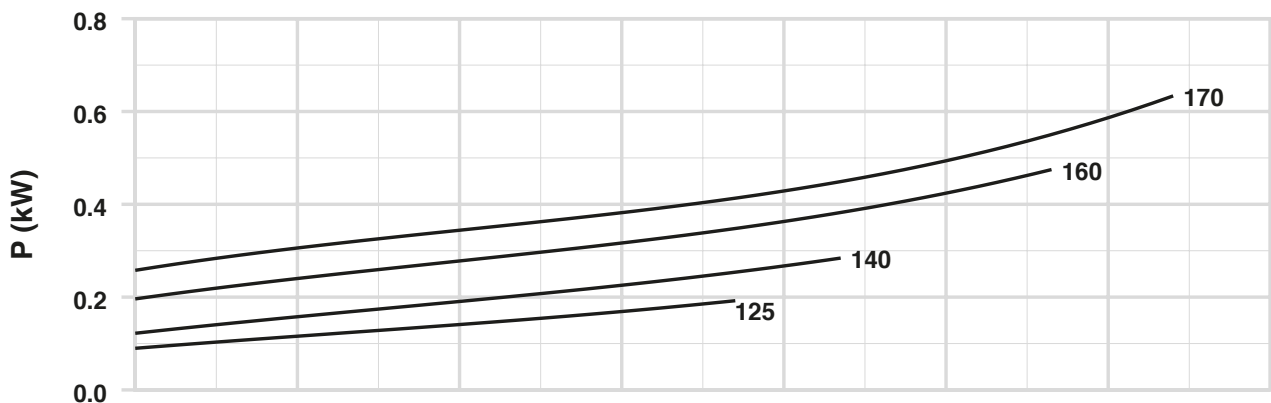
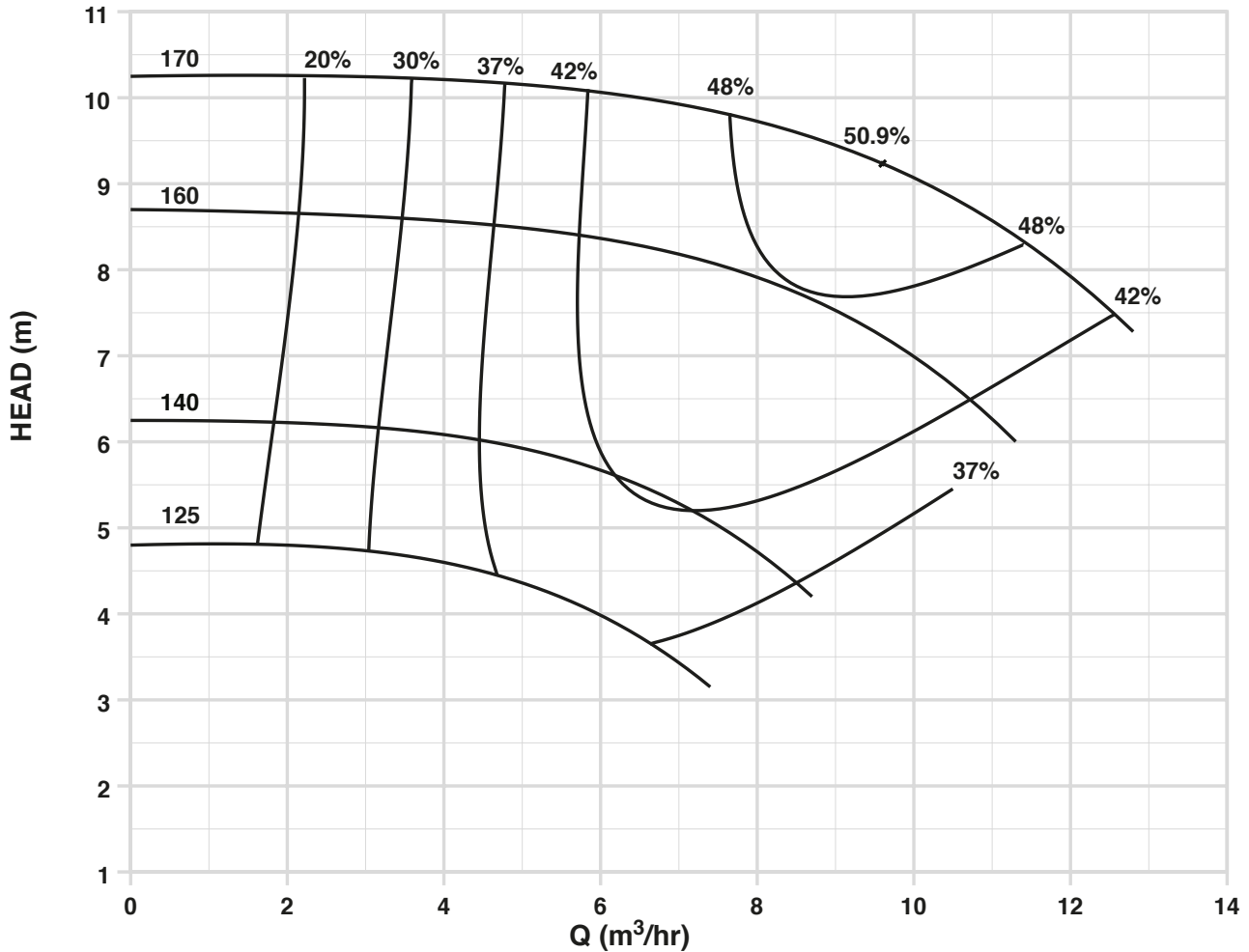

1450

CLT & CLB

MEDIUM-DUTY CENTRIFUGAL CHEMICAL PUMPS TO EN 733 (DIN 24256)



CHARACTERISTIC CURVE

Issue Date
OCTOBER 2005

Suction Diameter
50mm

Discharge Diameter
32mm

DIN 24 256
CLT 32- 200

Based on water density 1000 kg/m³ and viscosity 1 cSt.
Head, capacity and efficiency according to ISO Standard 2548: 1973 Annex B

1450 rpm

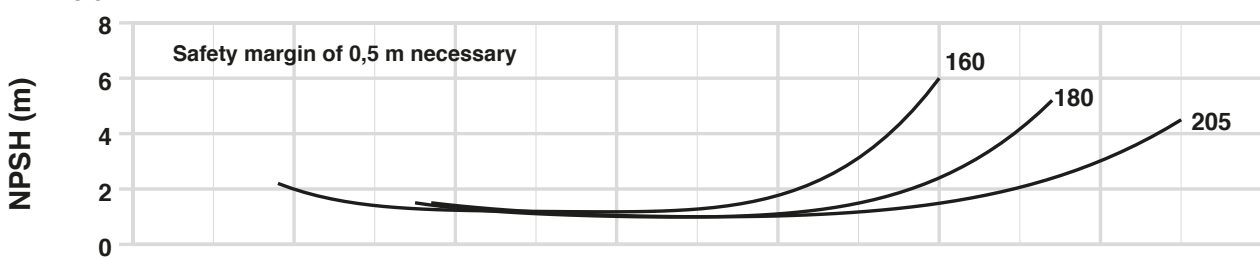
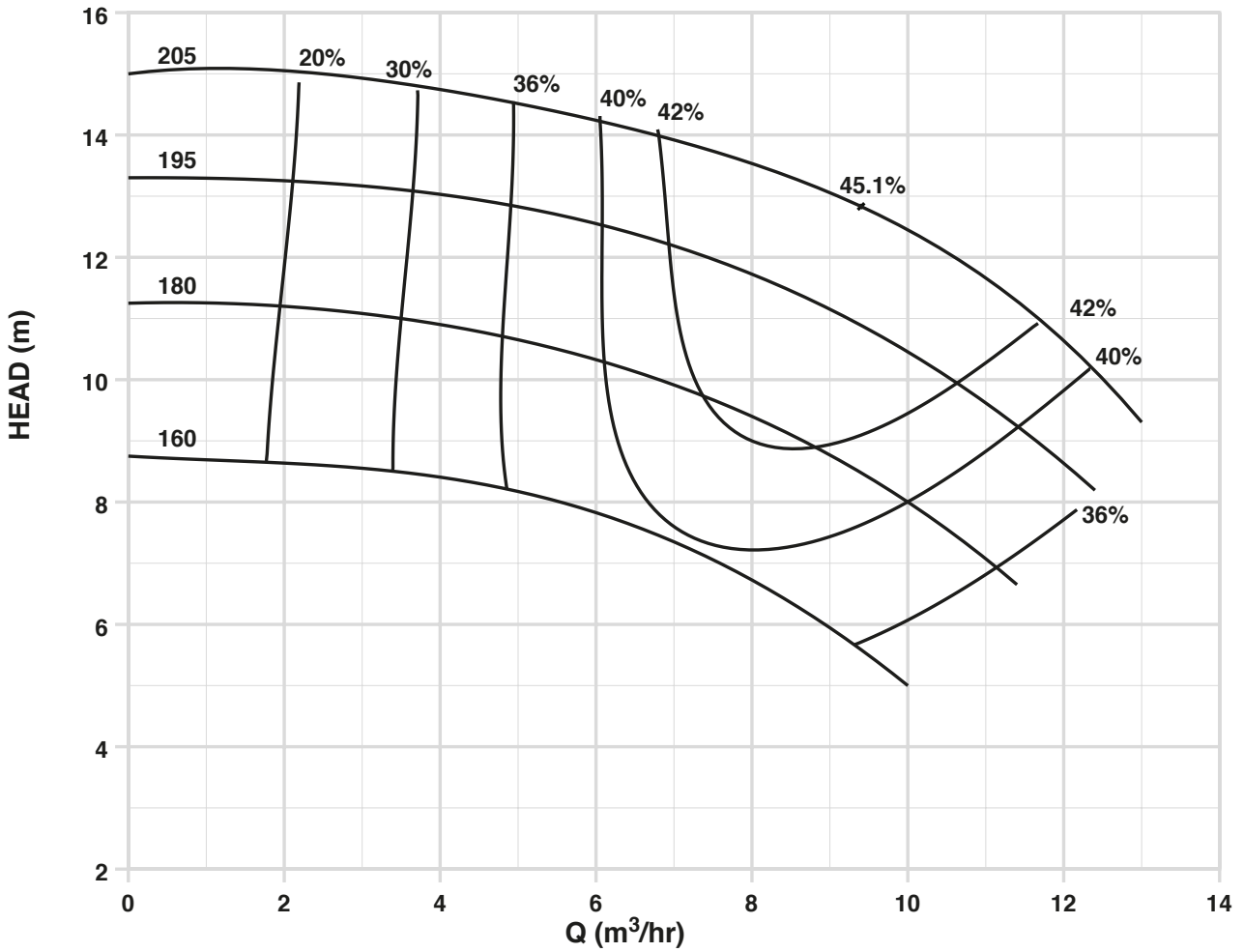

1450

CLT & CLB

MEDIUM-DUTY CENTRIFUGAL CHEMICAL PUMPS TO EN 733 (DIN 24256)



CHARACTERISTIC CURVE

Issue Date
OCTOBER 2005

Suction Diameter
50mm

Discharge Diameter
32mm

DIN 24 256
CLT 32- 250

Based on water density 1000 kg/m³ and viscosity 1 cSt.
Head, capacity and efficiency according to ISO Standard 2548: 1973 Annex B

1450 rpm

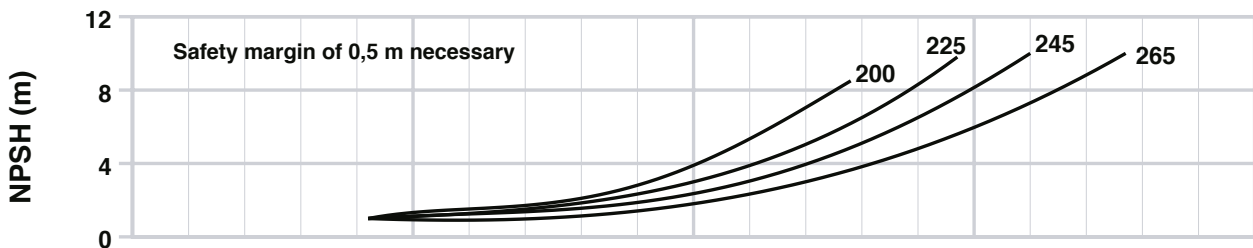
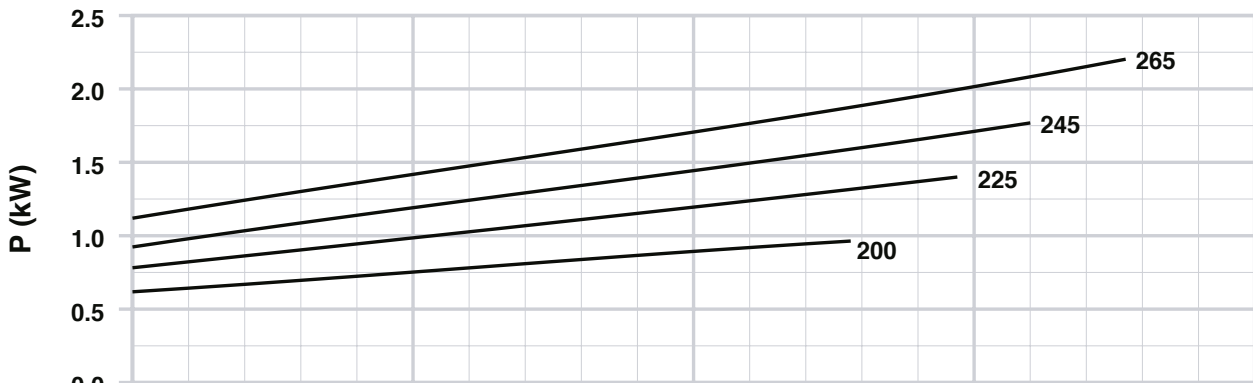
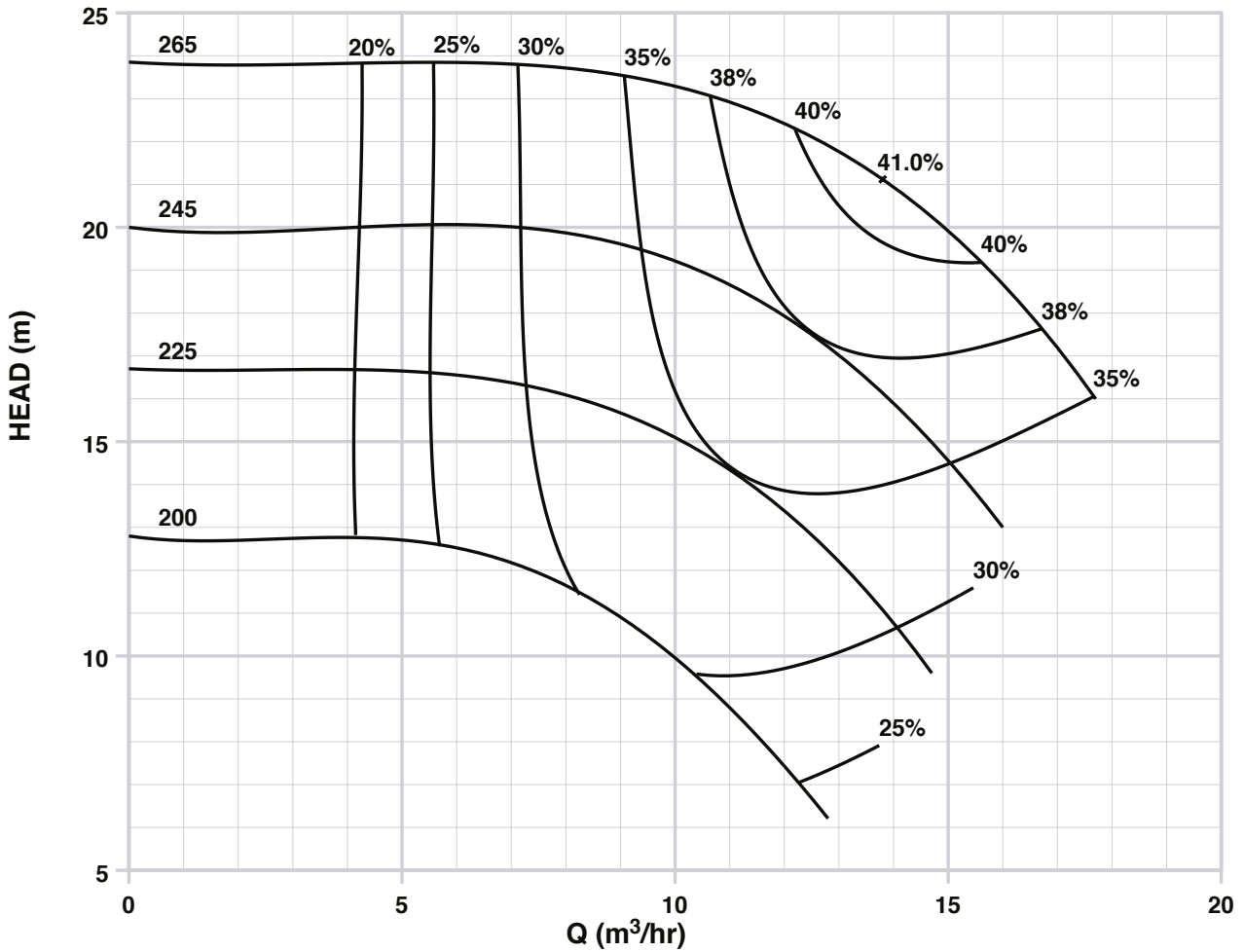

1450

CLT & CLB

MEDIUM-DUTY CENTRIFUGAL CHEMICAL PUMPS TO EN 733 (DIN 24256)



CHARACTERISTIC CURVE

Issue Date
OCTOBER 2005

Suction Diameter
65mm

Discharge Diameter
40mm

DIN 24 256
CLT 40 - 160

Based on water density 1000 kg/m³ and viscosity 1 cSt.
Head, capacity and efficiency according to ISO Standard 2548: 1973 Annex B

1450 rpm

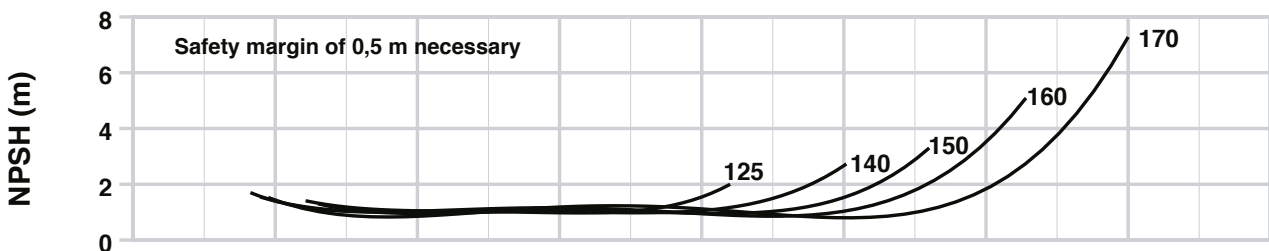
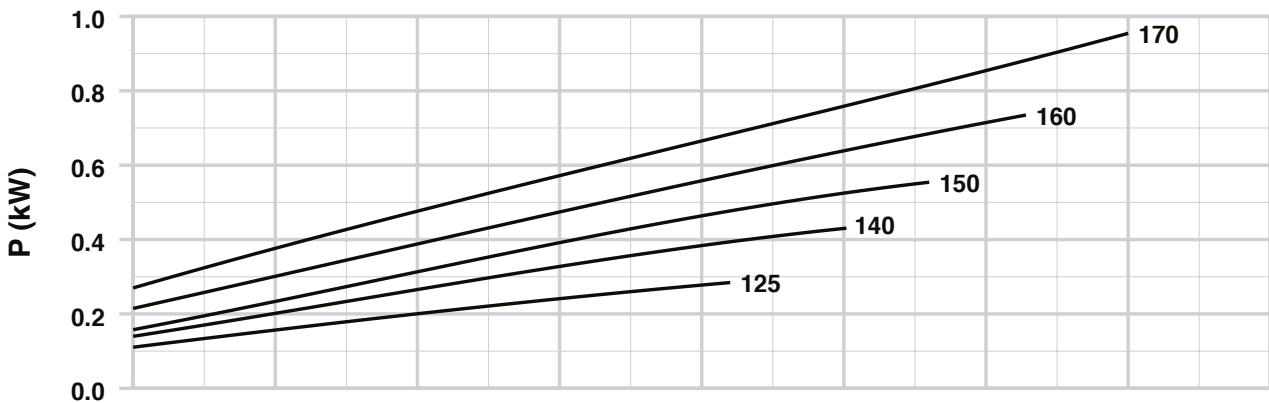
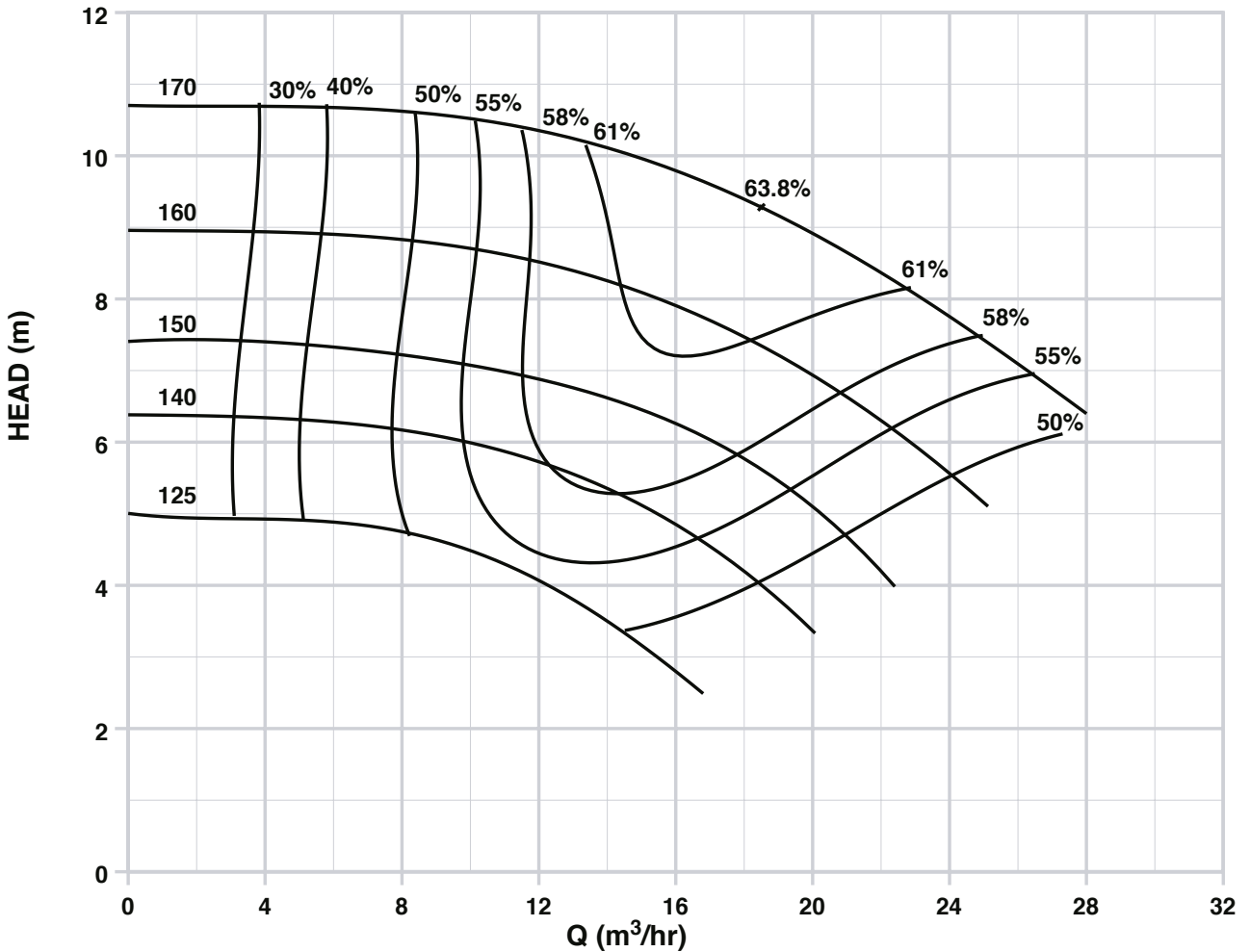

1450

CLT & CLB

MEDIUM-DUTY CENTRIFUGAL CHEMICAL PUMPS TO EN 733 (DIN 24256)



CHARACTERISTIC CURVE

Issue Date
OCTOBER 2005

Suction Diameter
65mm

Discharge Diameter
40mm

DIN 24 256
CLT 40- 200

Based on water density 1000 kg/m³ and viscosity 1 cSt.
Head, capacity and efficiency according to ISO Standard 2548: 1973 Annex B

1450 rpm

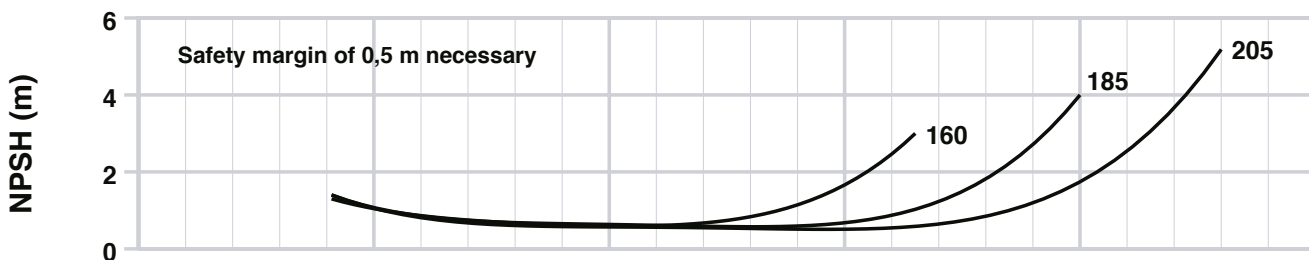
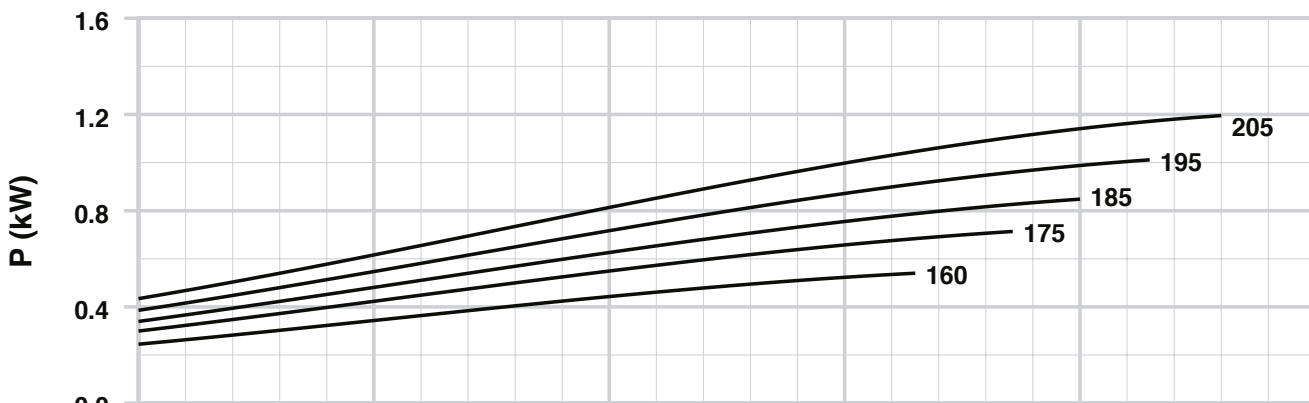
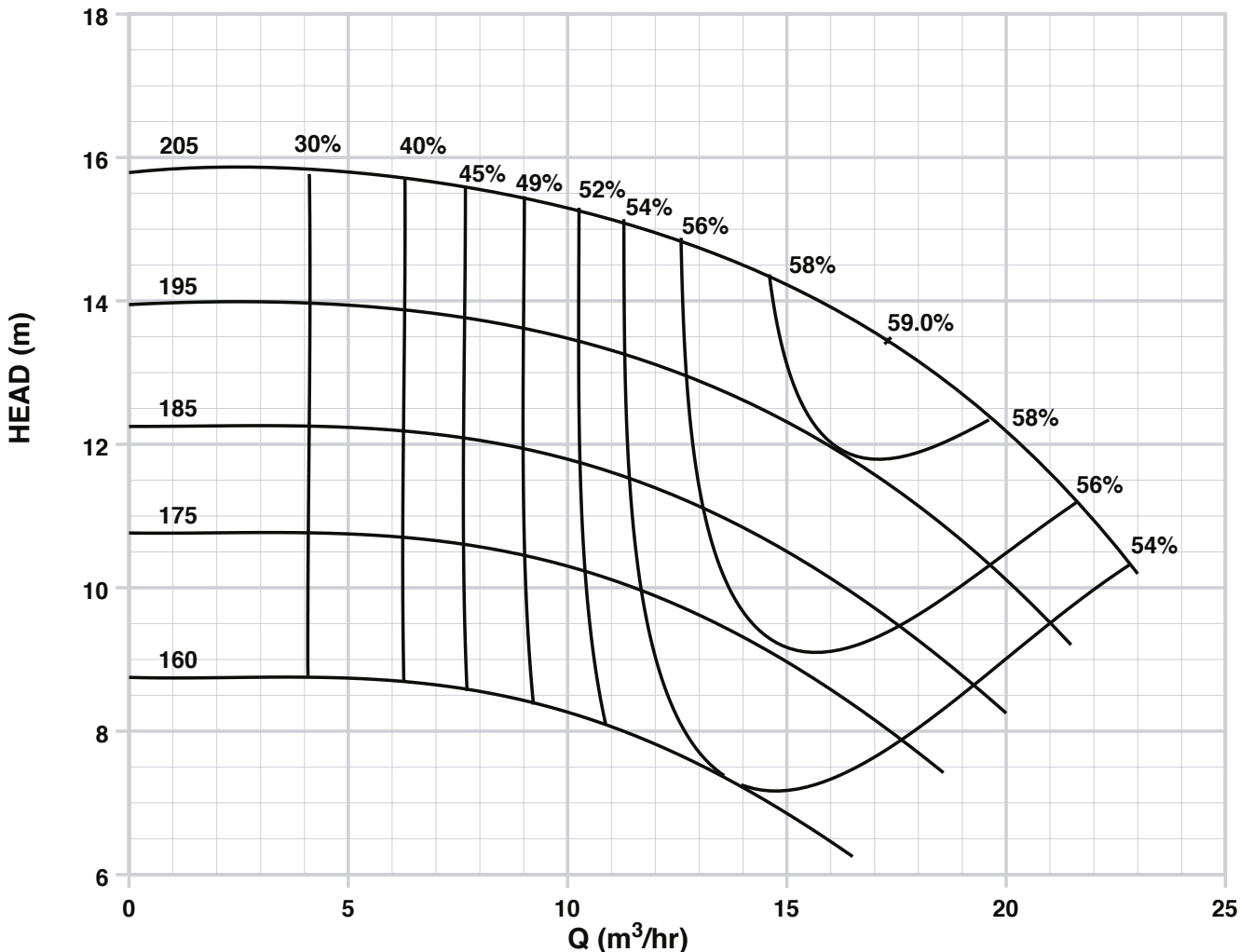

1450

CLT & CLB

MEDIUM-DUTY CENTRIFUGAL CHEMICAL PUMPS TO EN 733 (DIN 24256)



CHARACTERISTIC CURVE

Issue Date
OCTOBER 2005

Suction Diameter
65mm

Discharge Diameter
40mm

DIN 24 256
CLT 40-250

Based on water density 1000 kg/m³ and viscosity 1 cSt.
Head, capacity and efficiency according to ISO Standard 2548: 1973 Annex B

1450 rpm

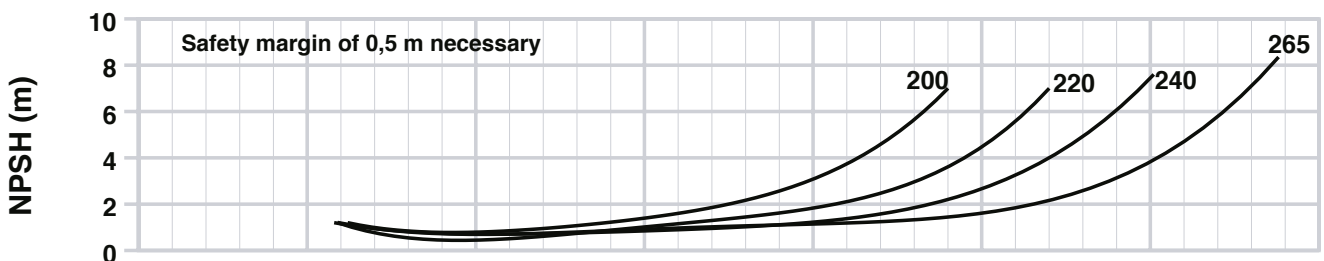
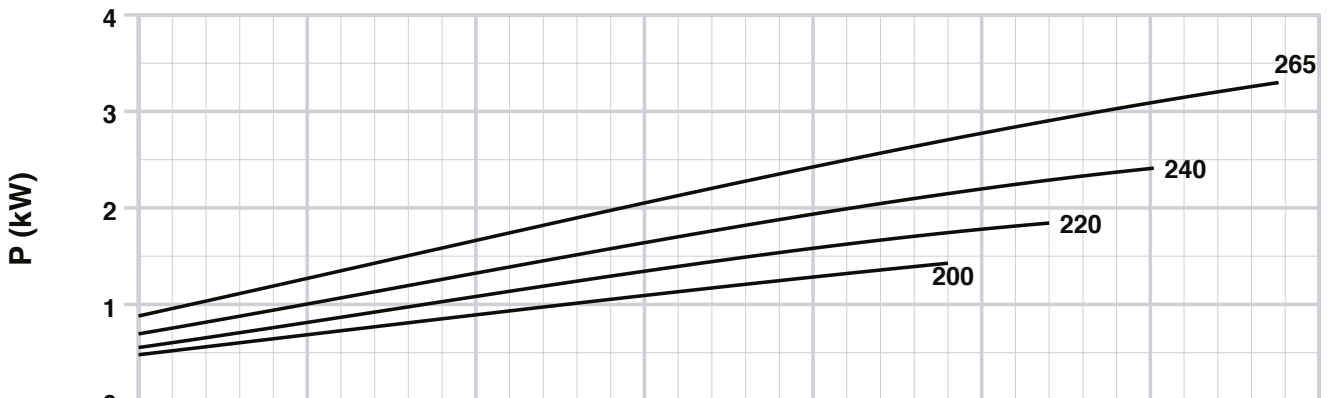
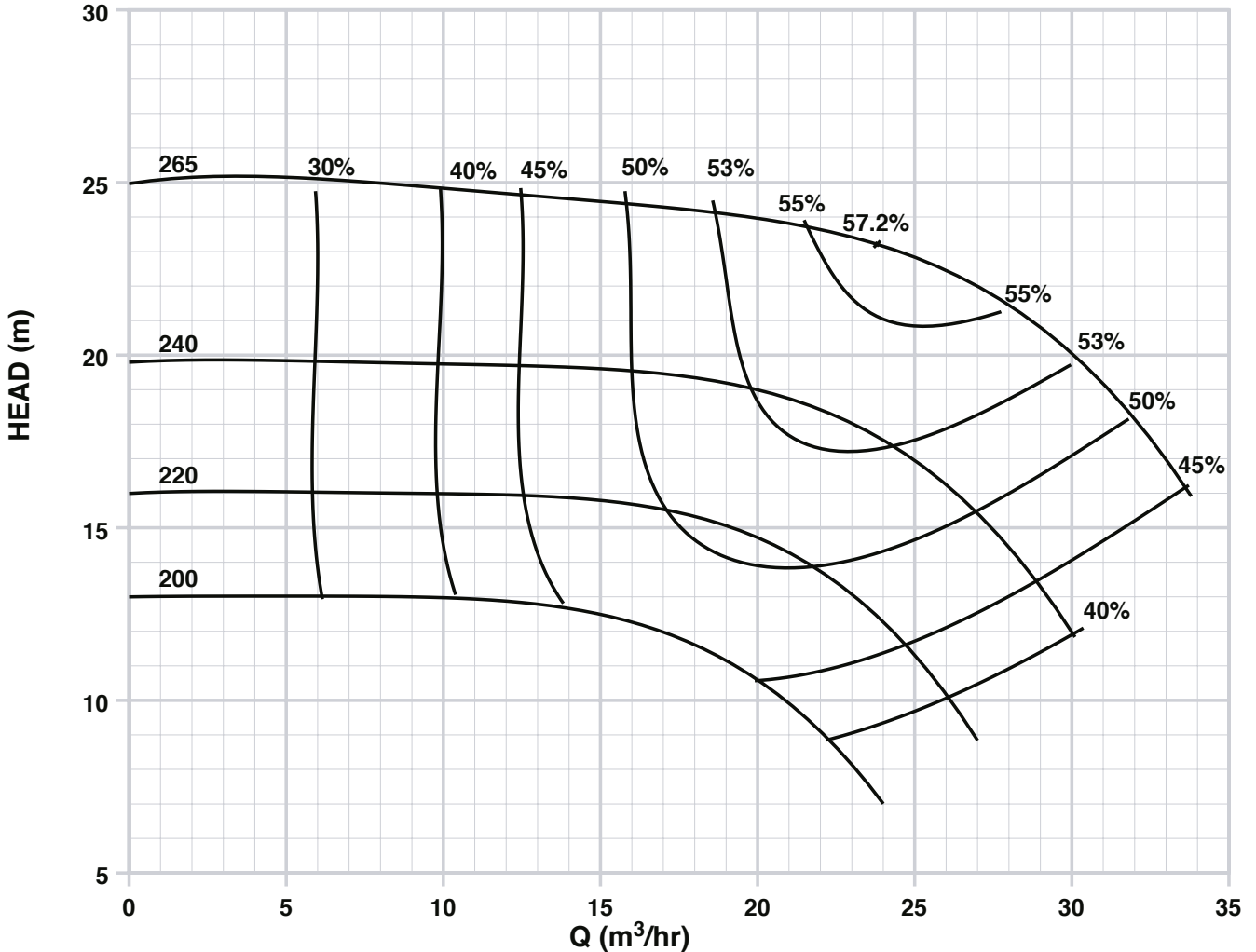

1450

CLT & CLB

MEDIUM-DUTY CENTRIFUGAL CHEMICAL PUMPS TO EN 733 (DIN 24256)



CHARACTERISTIC CURVE

DIN 24 256
CLT 40-315

Issue Date
OCTOBER 2005

Suction Diameter
65mm

Discharge Diameter
40mm

Based on water density 1000 kg/m³ and viscosity 1 cSt.
Head, capacity and efficiency according to ISO Standard 2548: 1973 Annex B

1450 rpm

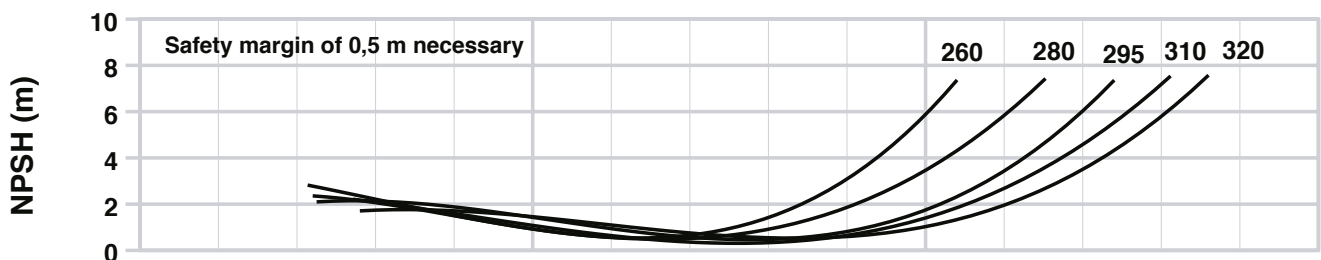
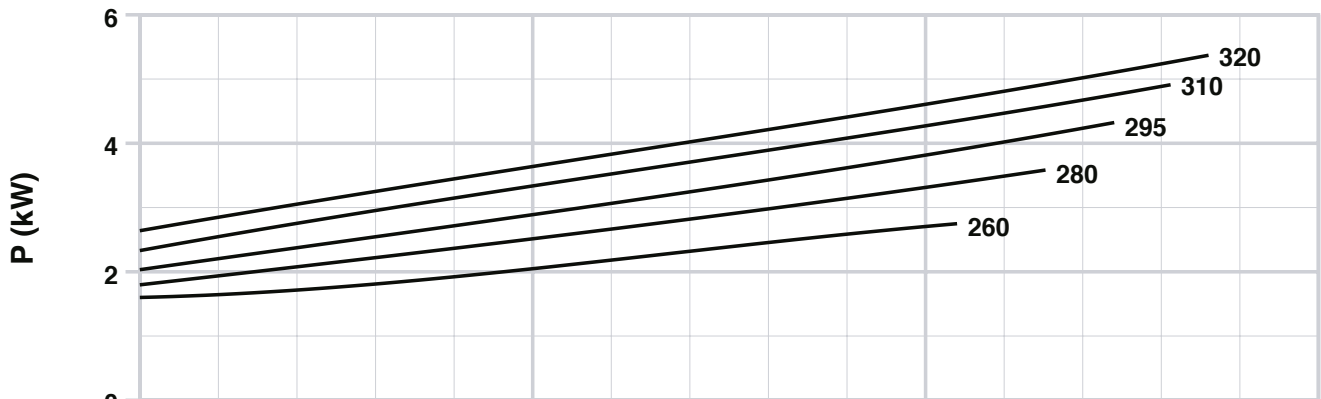
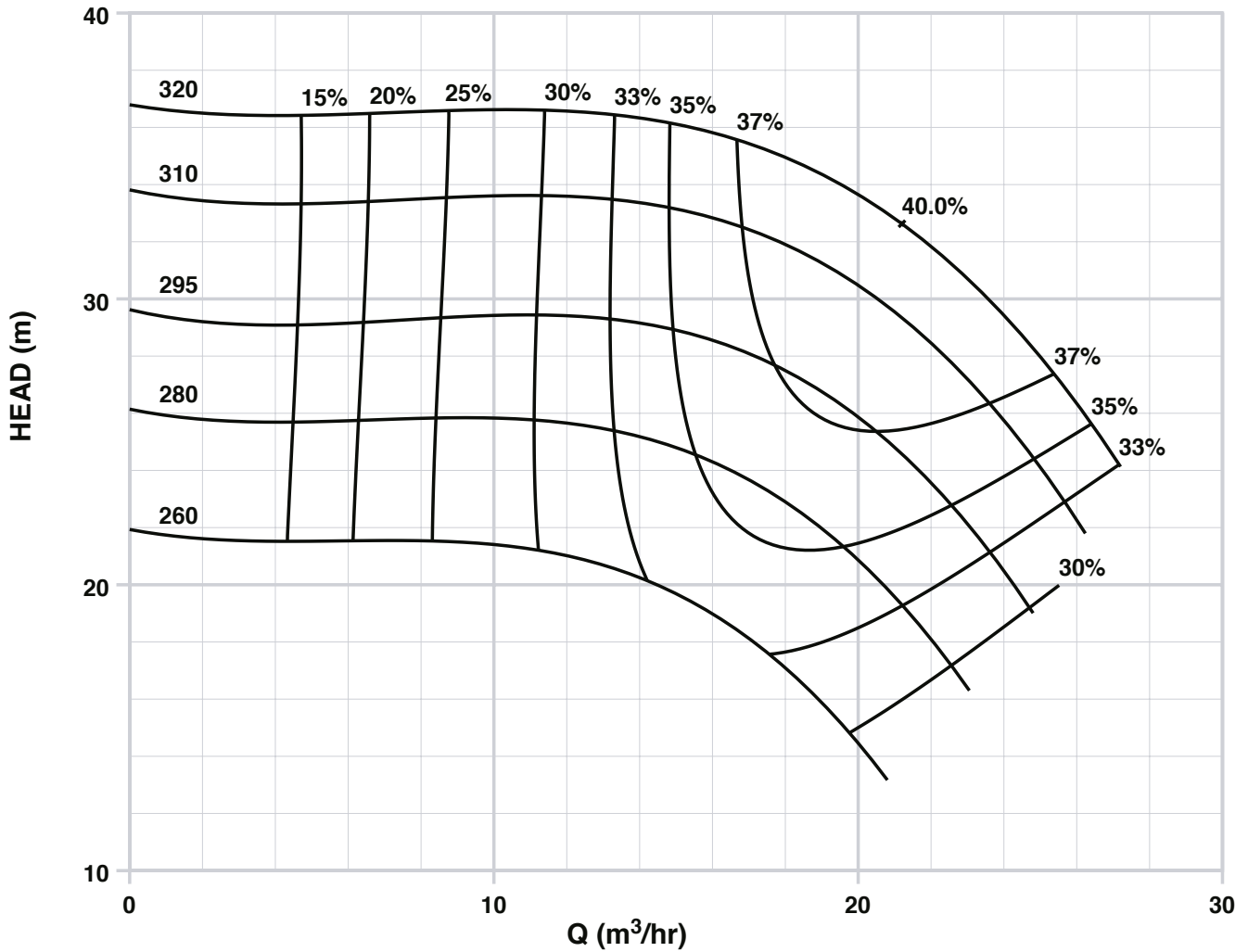

1450

CLT & CLB

MEDIUM-DUTY CENTRIFUGAL CHEMICAL PUMPS TO EN 733 (DIN 24256)



CHARACTERISTIC CURVE

Issue Date
OCTOBER 2005

Suction Diameter
80mm

Discharge Diameter
50mm

DIN 24 256
CLT 50-160

Based on water density 1000 kg/m³ and viscosity 1 cSt.
Head, capacity and efficiency according to ISO Standard 2548: 1973 Annex B

1450 rpm

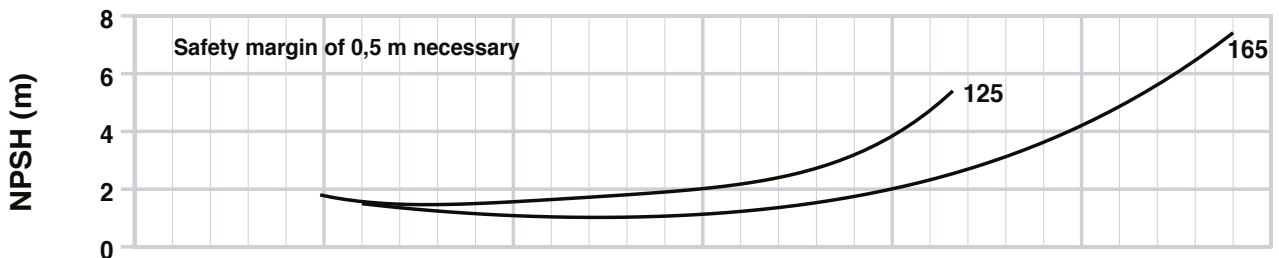
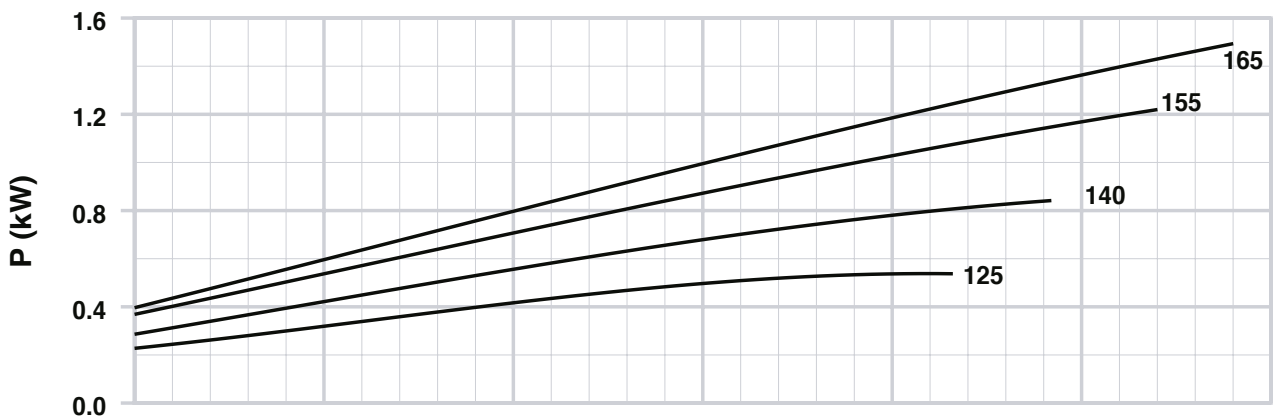
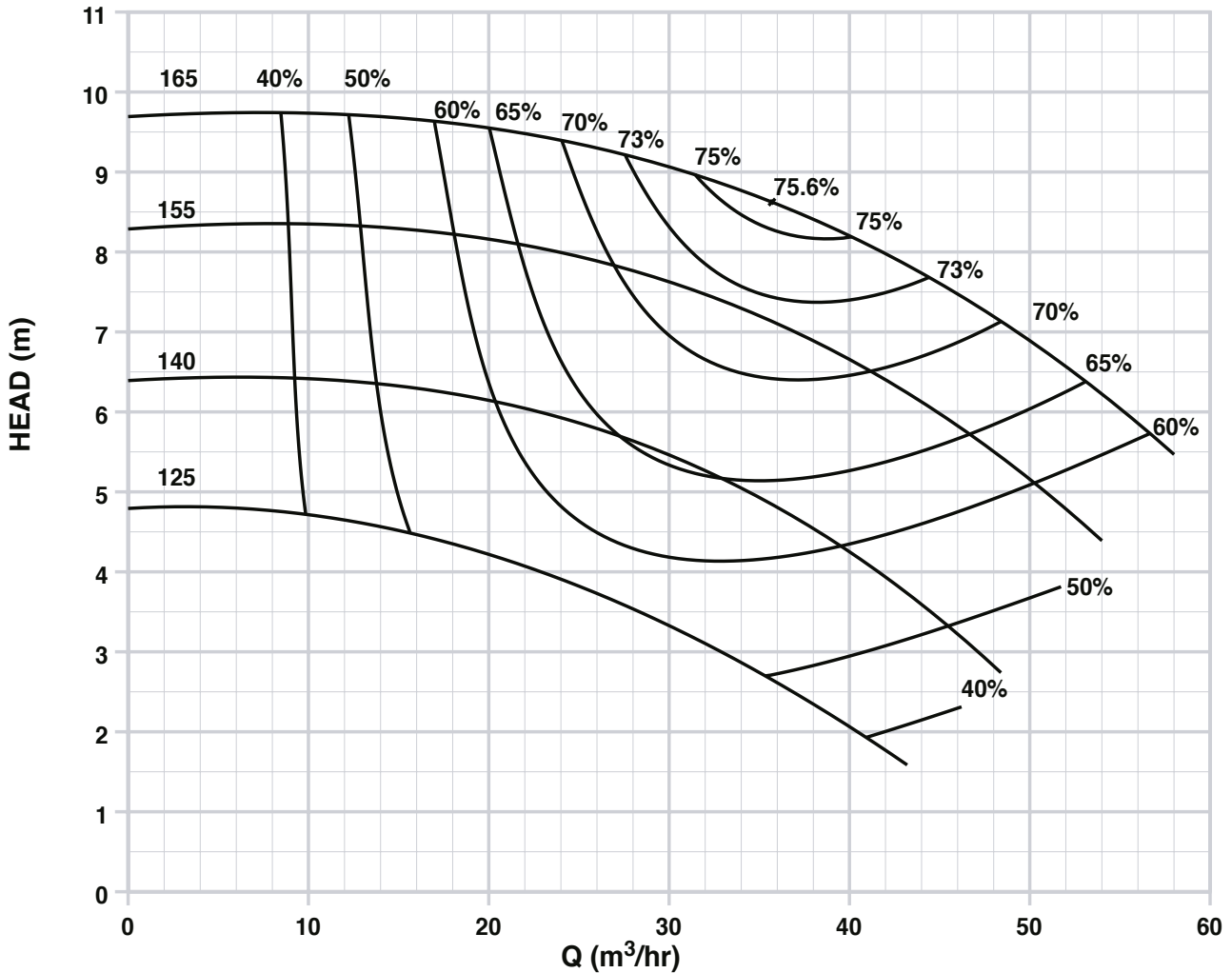

1450

CLT & CLB

MEDIUM-DUTY CENTRIFUGAL CHEMICAL PUMPS TO EN 733 (DIN 24256)



CHARACTERISTIC CURVE

DIN 24 256
CLT 50-200

Issue Date
OCTOBER 2005

Suction Diameter
80mm

Discharge Diameter
50mm

Based on water density 1000 kg/m³ and viscosity 1 cSt.
Head, capacity and efficiency according to ISO Standard 2548: 1973 Annex B

1450 rpm

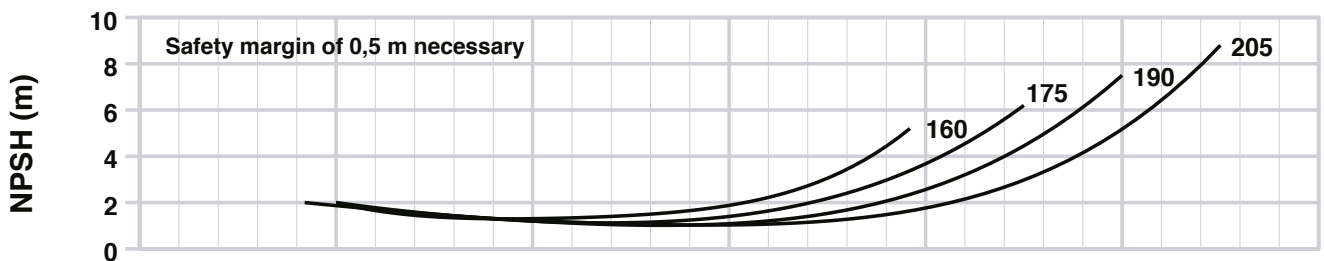
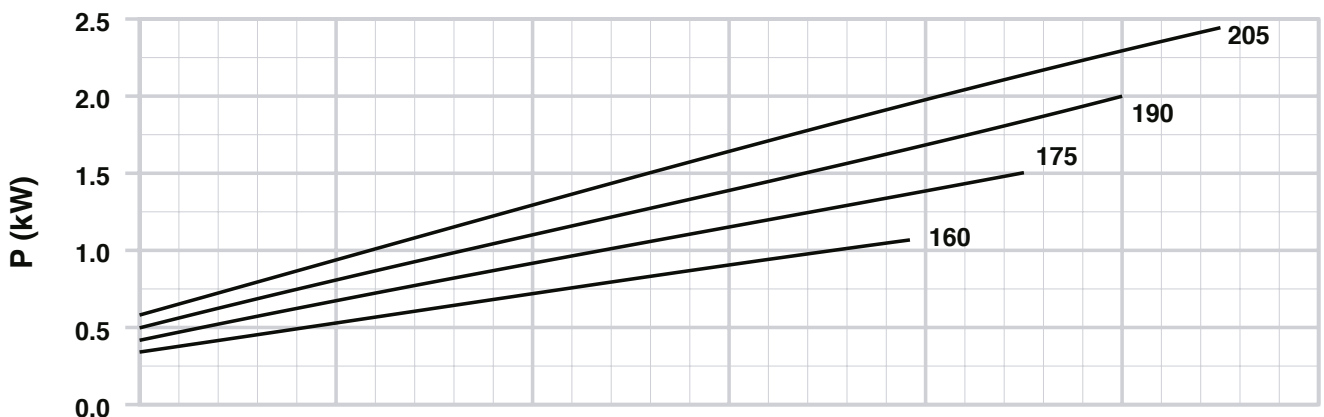
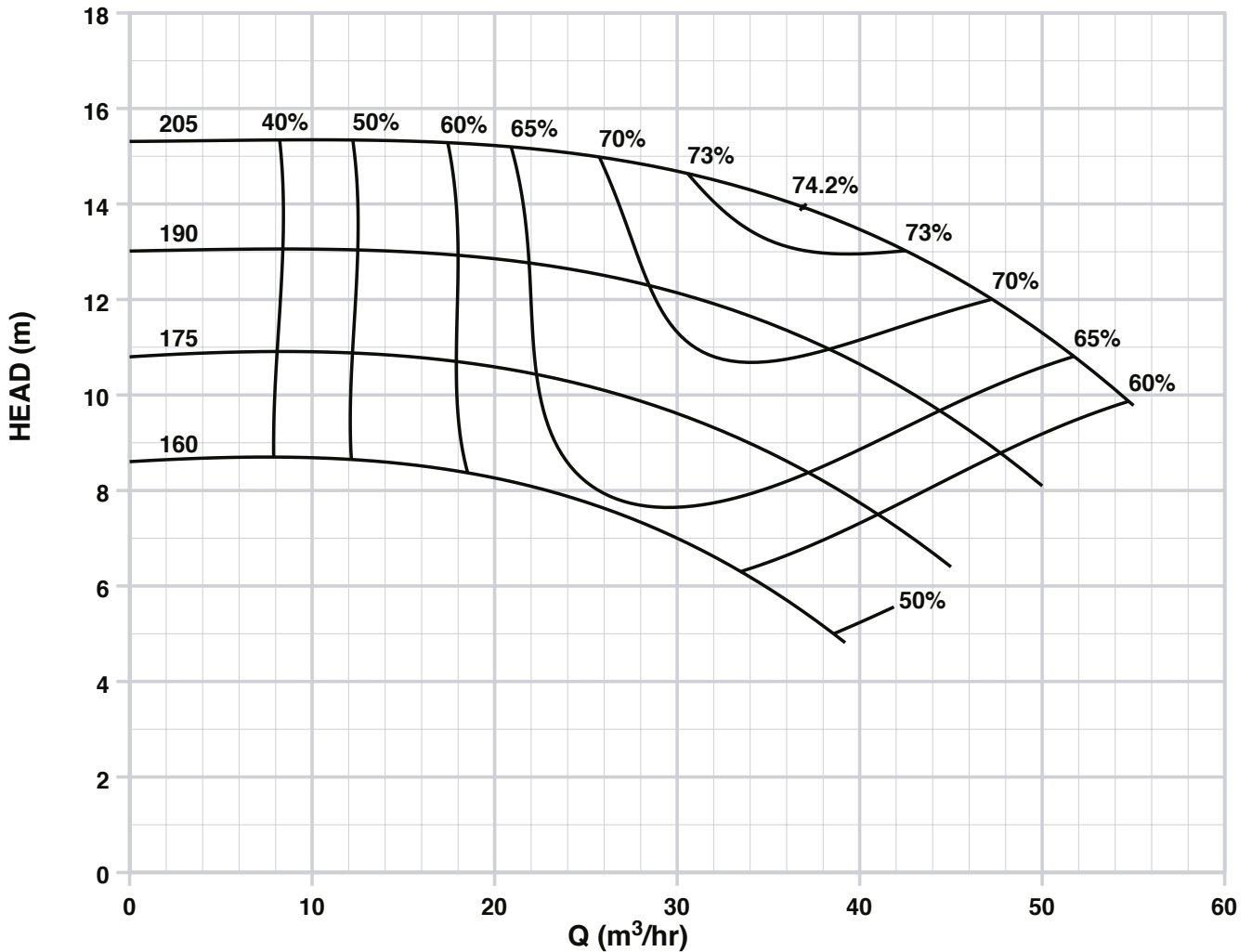

1450

CLT & CLB

MEDIUM-DUTY CENTRIFUGAL CHEMICAL PUMPS TO EN 733 (DIN 24256)



CHARACTERISTIC CURVE

Issue Date
OCTOBER 2005

Suction Diameter
80mm

Discharge Diameter
50mm

DIN 24 256
CLT 50-250

Based on water density 1000 kg/m³ and viscosity 1 cSt.
Head, capacity and efficiency according to ISO Standard 2548: 1973 Annex B

1450 rpm

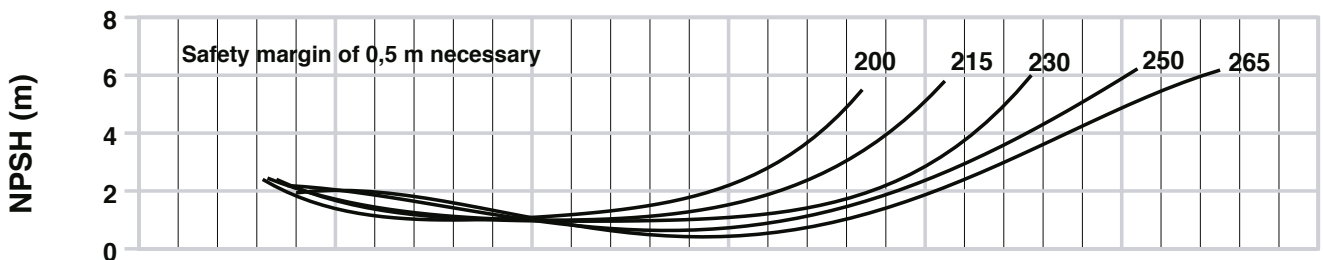
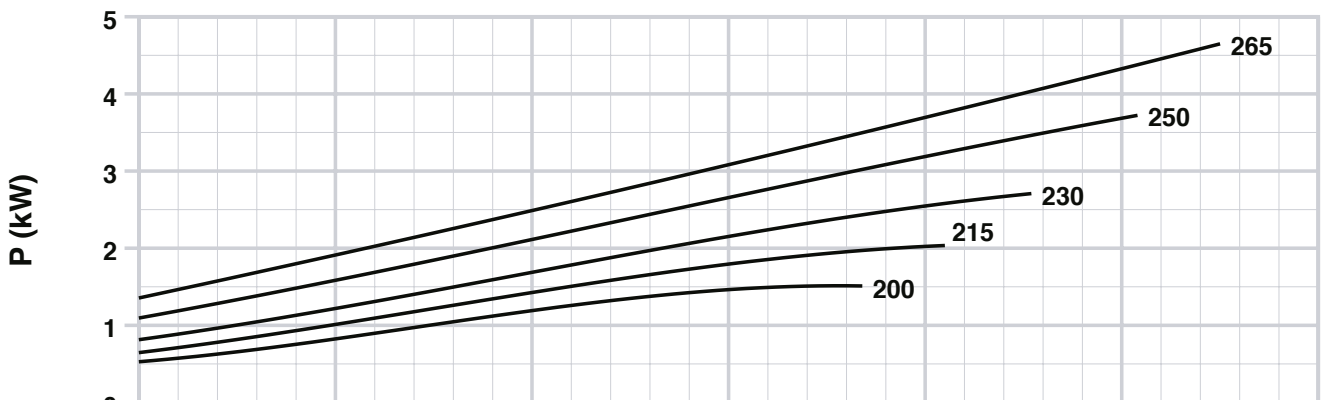
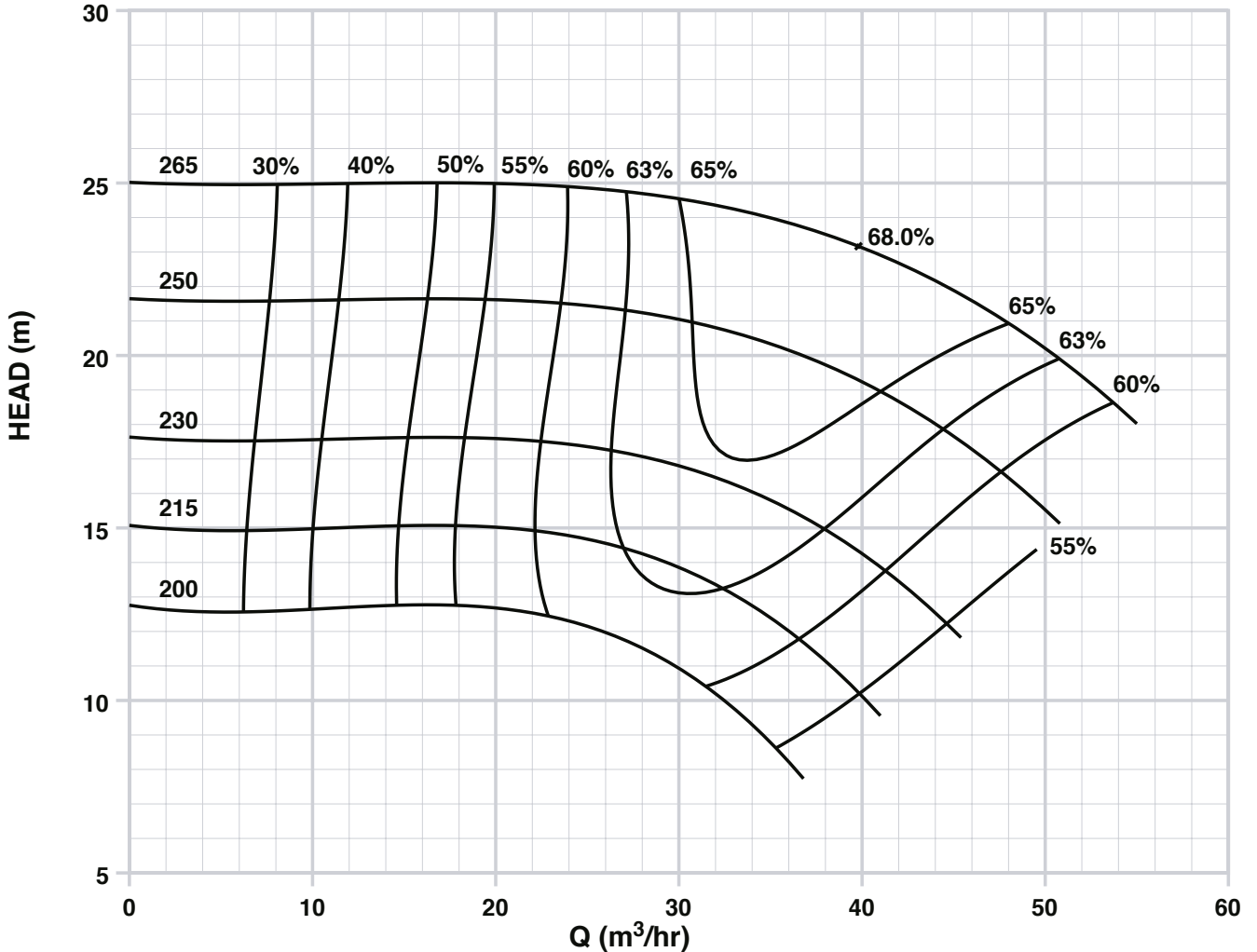

1450

CLT & CLB

MEDIUM-DUTY CENTRIFUGAL CHEMICAL PUMPS TO EN 733 (DIN 24256)



CHARACTERISTIC CURVE

DIN 24 256
CLT 50-315

Issue Date
OCTOBER 2005

Suction Diameter
80mm

Discharge Diameter
50mm

Based on water density 1000 kg/m³ and viscosity 1 cSt.
Head, capacity and efficiency according to ISO Standard 2548: 1973 Annex B

1450 rpm

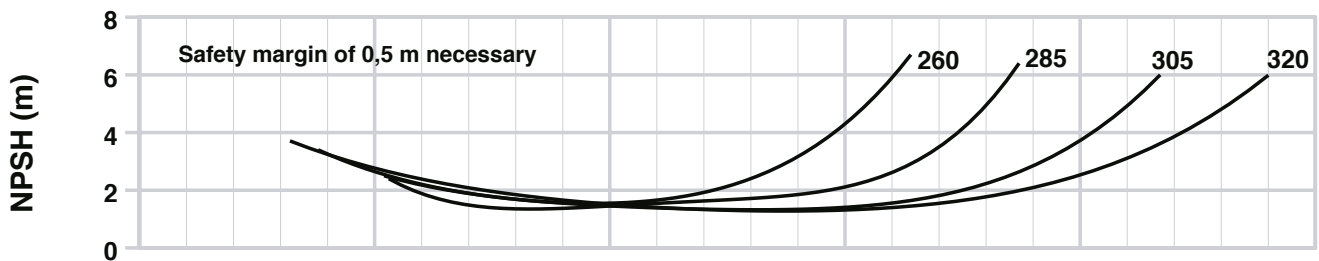
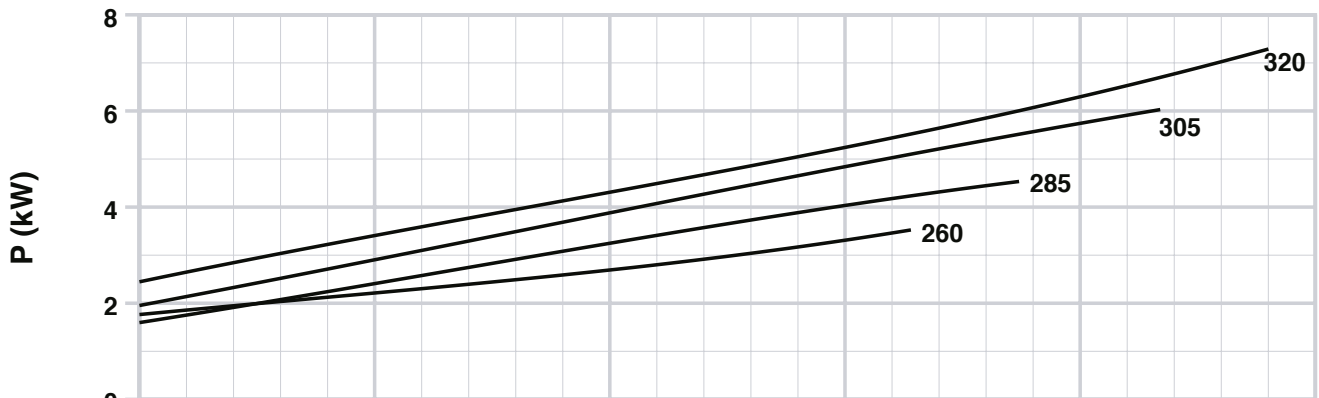
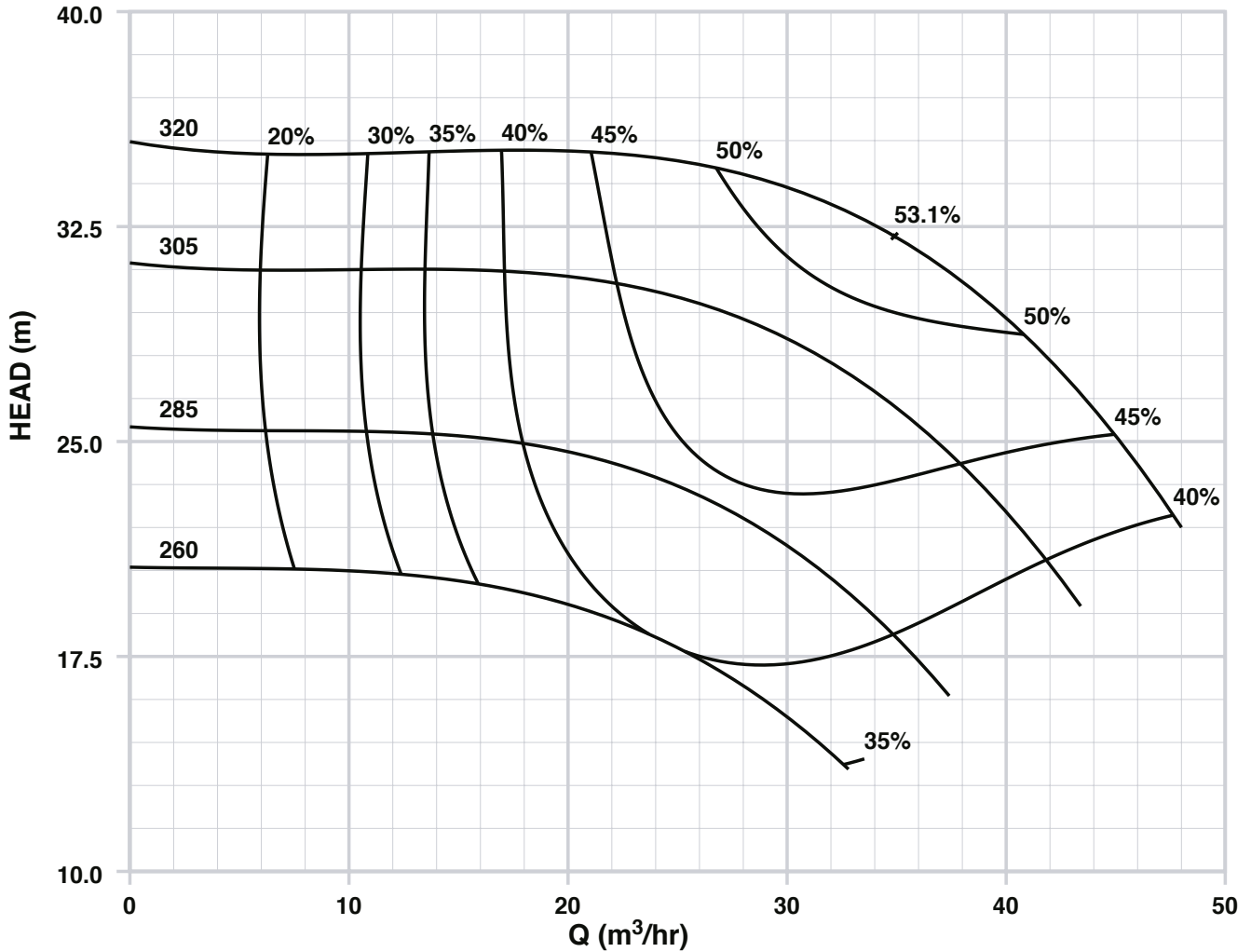

1450

CLT & CLB

MEDIUM-DUTY CENTRIFUGAL CHEMICAL PUMPS TO EN 733 (DIN 24256)



CHARACTERISTIC CURVE

Issue Date
OCTOBER 2005

Suction Diameter
100mm

Discharge Diameter
65mm

DIN 24 256
CLT 65-160

Based on water density 1000 kg/m³ and viscosity 1 cSt.
Head, capacity and efficiency according to ISO Standard 2548: 1973 Annex B

1450 rpm

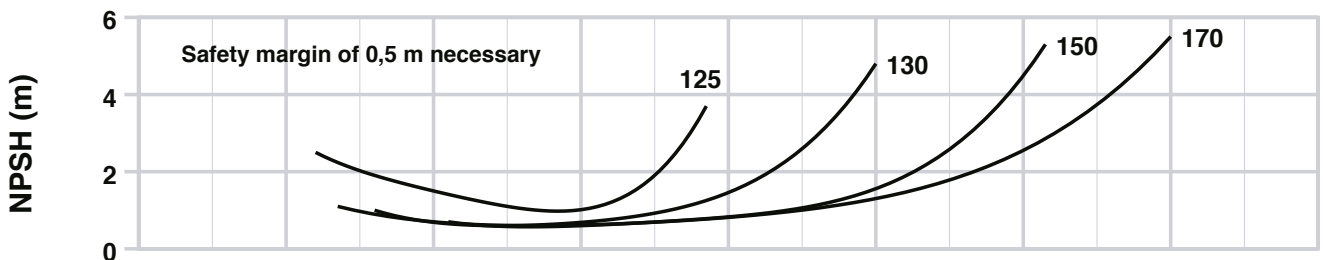
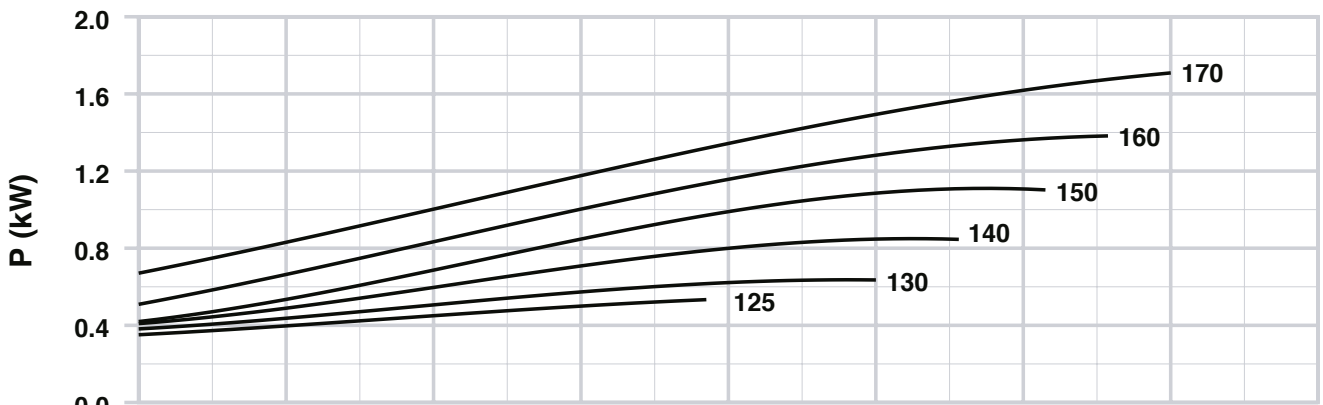
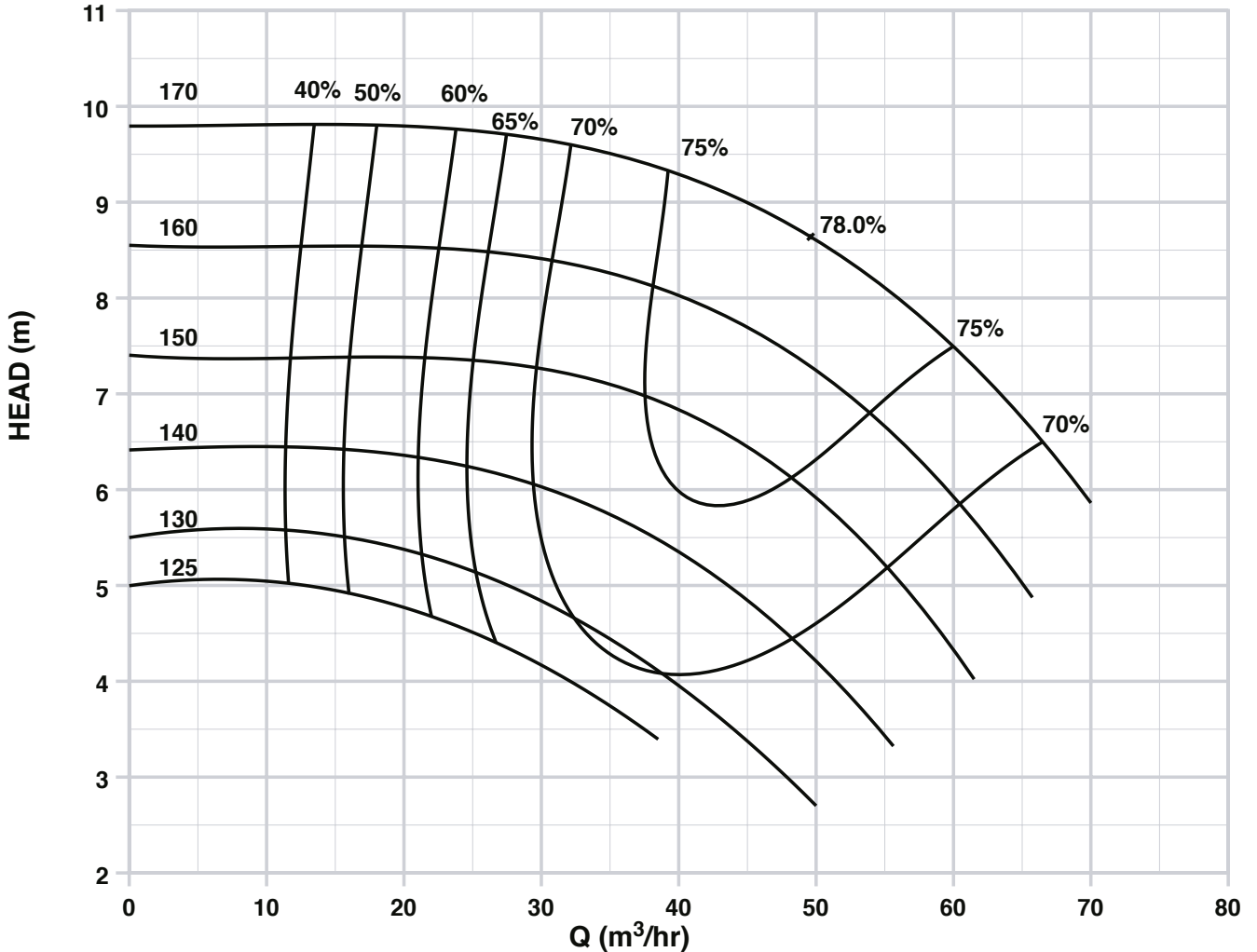

1450

CLT & CLB

MEDIUM-DUTY CENTRIFUGAL CHEMICAL PUMPS TO EN 733 (DIN 24256)



CHARACTERISTIC CURVE

Issue Date
OCTOBER 2005

Suction Diameter
100mm

Discharge Diameter
65mm

DIN 24 256
CLT 65-200

Based on water density 1000 kg/m³ and viscosity 1 cSt.
Head, capacity and efficiency according to ISO Standard 2548: 1973 Annex B

1450 rpm

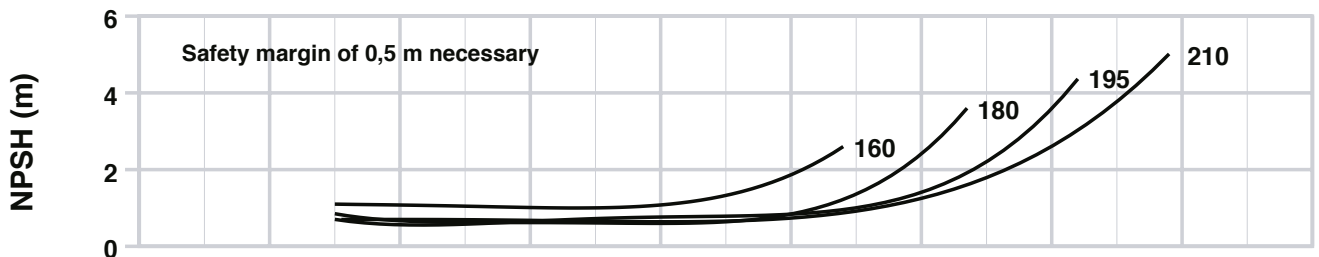
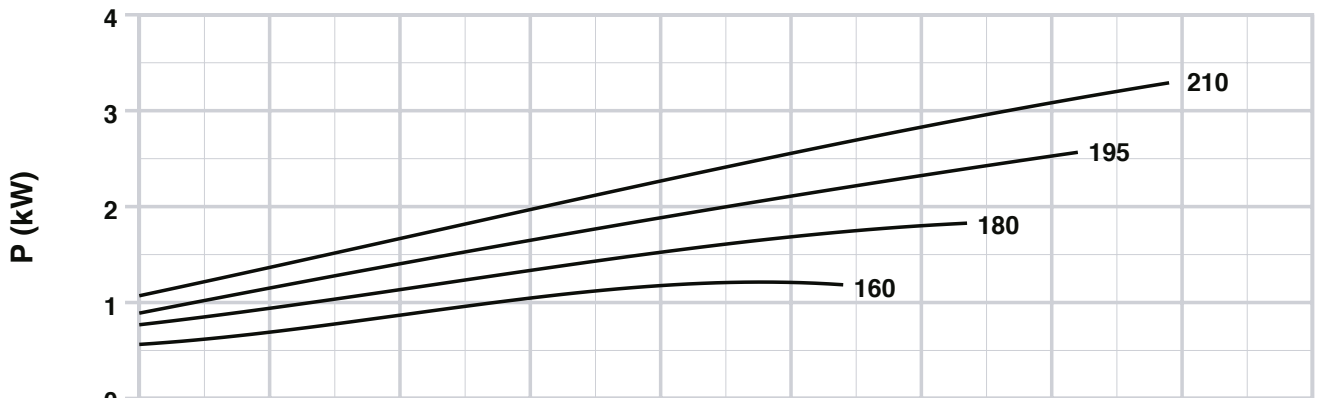
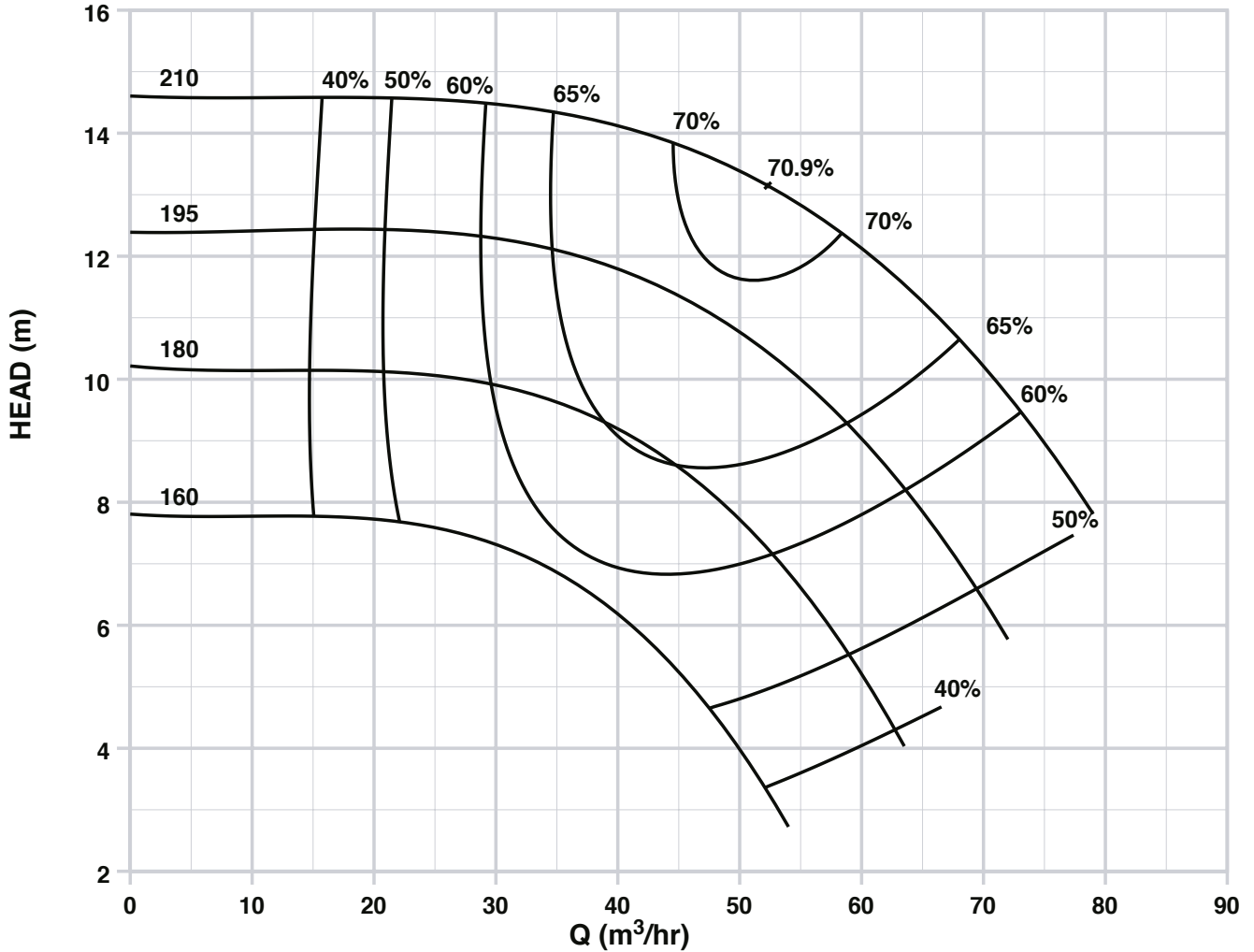

1450

CLT & CLB

MEDIUM-DUTY CENTRIFUGAL CHEMICAL PUMPS TO EN 733 (DIN 24256)



CHARACTERISTIC CURVE

Issue Date
OCTOBER 2005

Suction Diameter
100mm

Discharge Diameter
65mm

DIN 24 256
CLT 65-250

Based on water density 1000 kg/m³ and viscosity 1 cSt.
Head, capacity and efficiency according to ISO Standard 2548: 1973 Annex B

1450 rpm

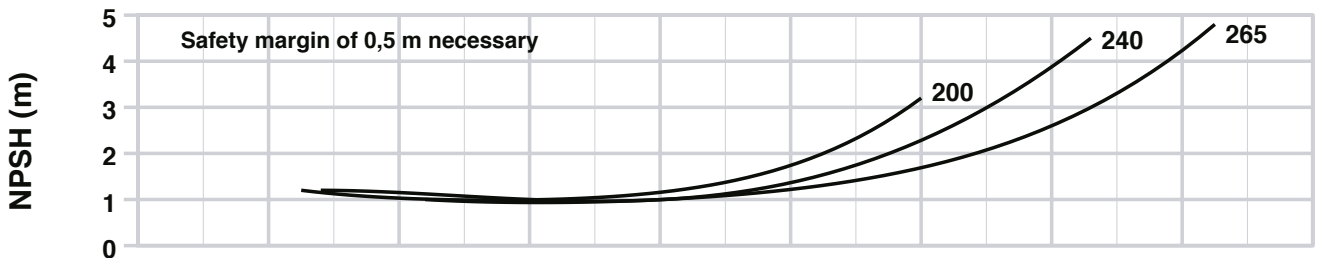
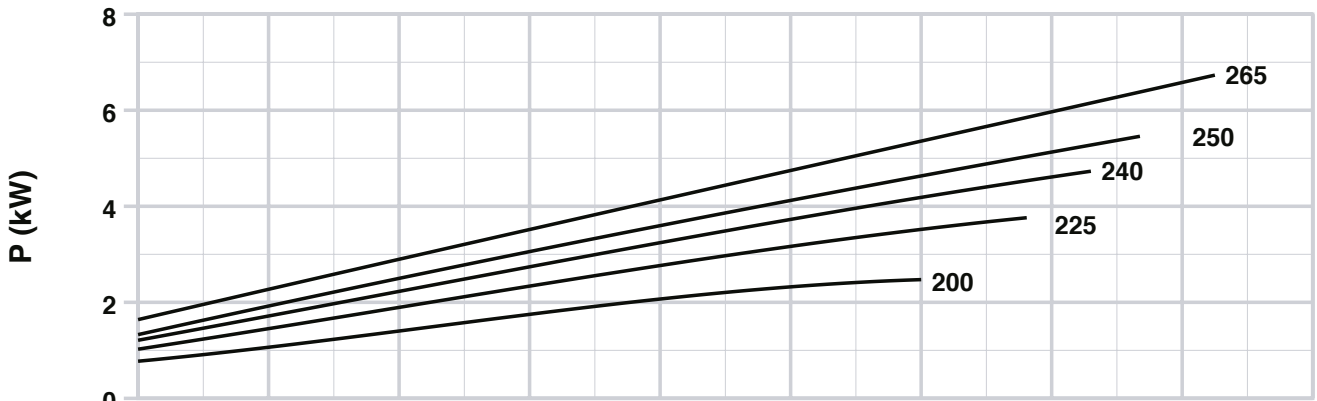
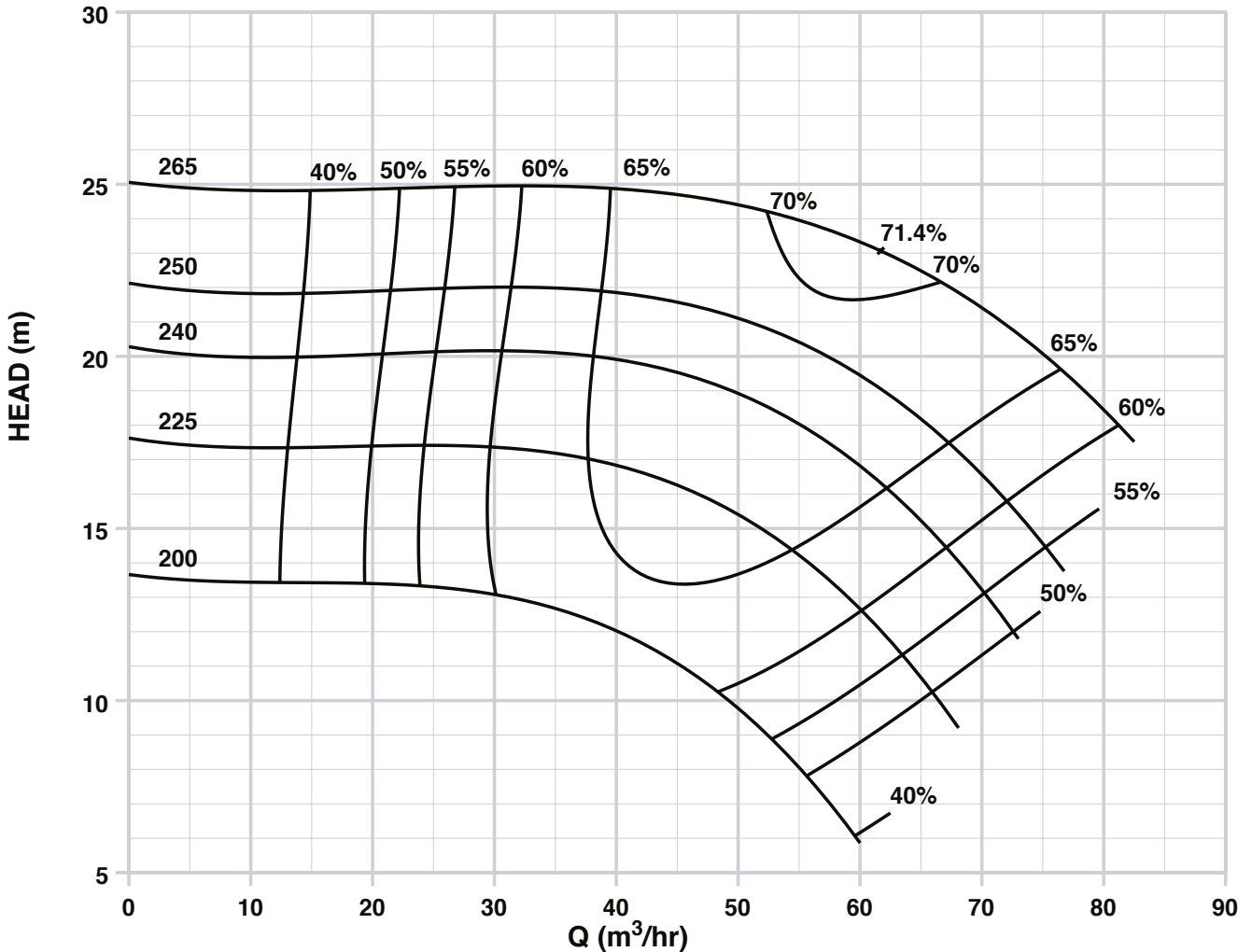

1450

CLT & CLB

MEDIUM-DUTY CENTRIFUGAL CHEMICAL PUMPS TO EN 733 (DIN 24256)



CHARACTERISTIC CURVE

Issue Date
OCTOBER 2005

Suction Diameter
100mm

Discharge Diameter
65mm

DIN 24 256
CLT 65-315

Based on water density 1000 kg/m³ and viscosity 1 cSt.
Head, capacity and efficiency according to ISO Standard 2548: 1973 Annex B

1450 rpm

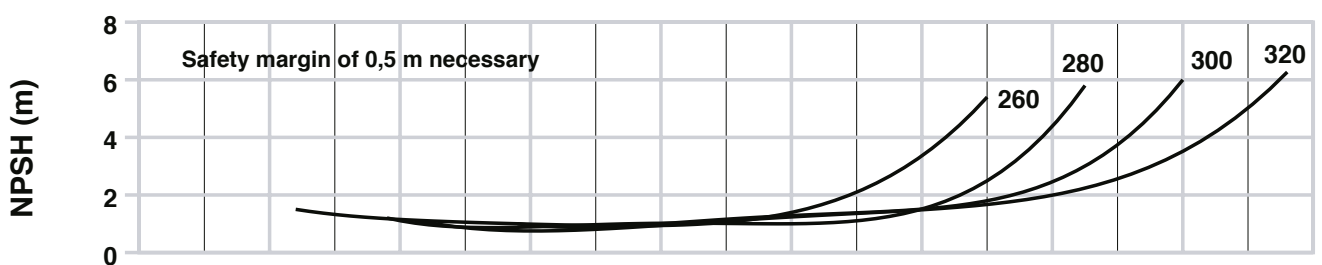
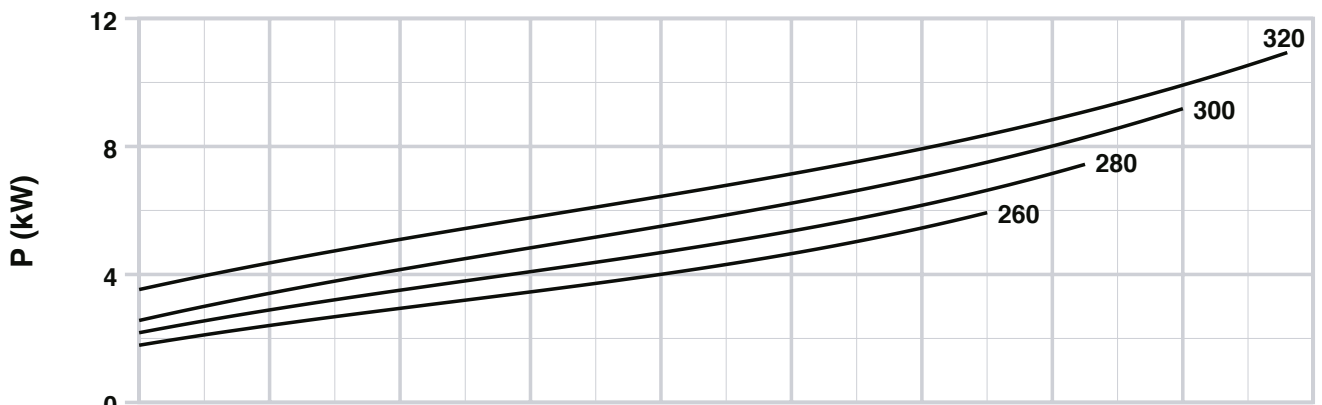
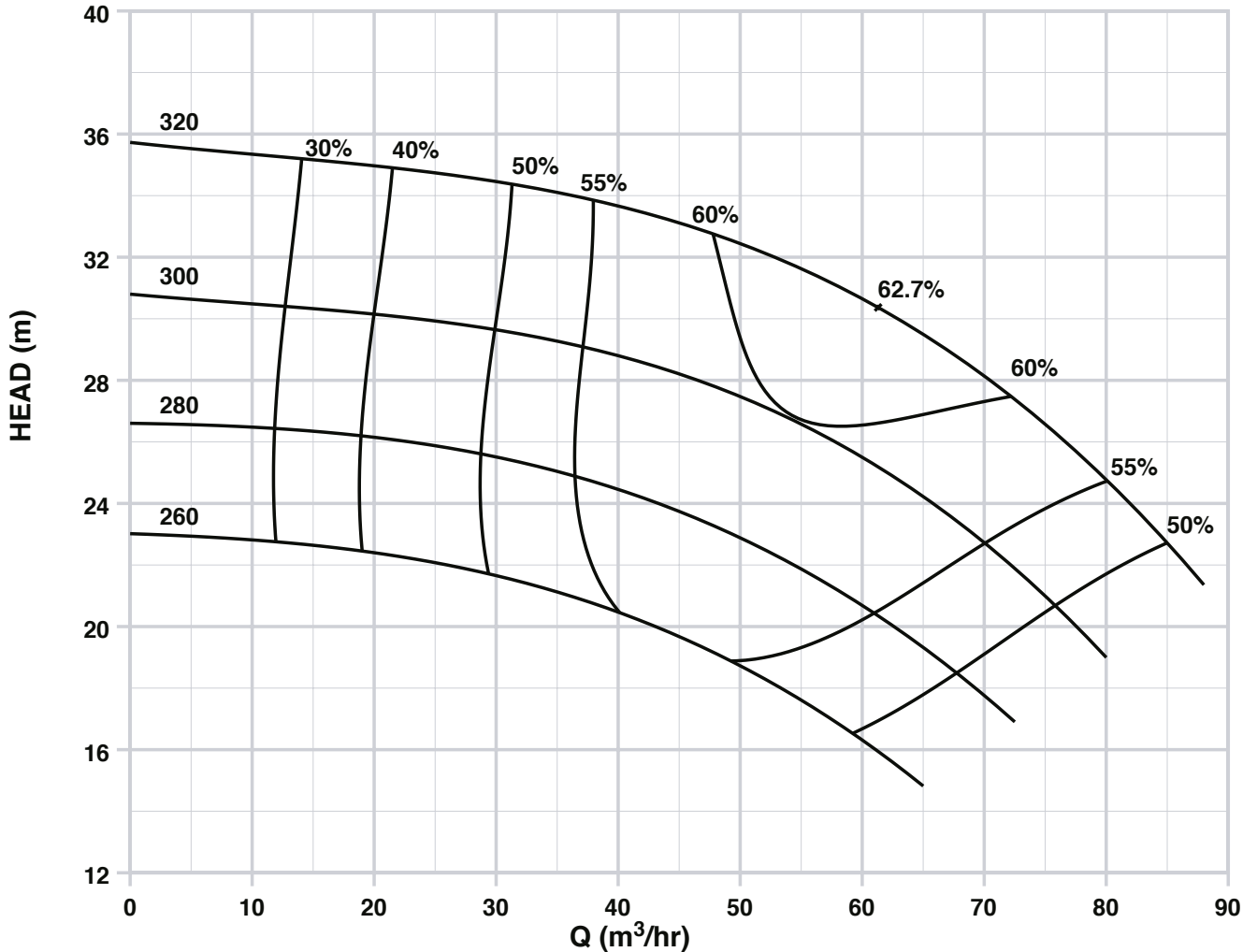

1450

CLT & CLB

MEDIUM-DUTY CENTRIFUGAL CHEMICAL PUMPS TO EN 733 (DIN 24256)



CHARACTERISTIC CURVE

Issue Date
OCTOBER 2005

Suction Diameter
125mm

Discharge Diameter
80mm

DIN 24 256
CLT 80-160

Based on water density 1000 kg/m³ and viscosity 1 cSt.
Head, capacity and efficiency according to ISO Standard 2548: 1973 Annex B

1450 rpm

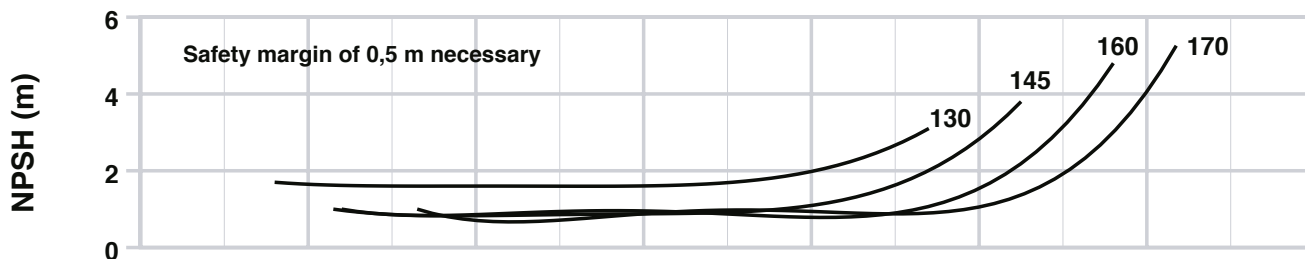
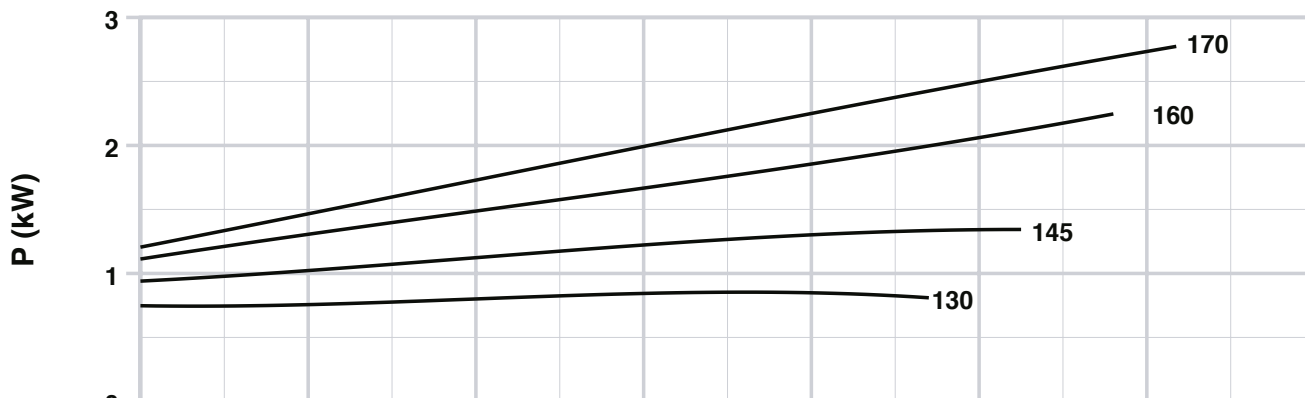
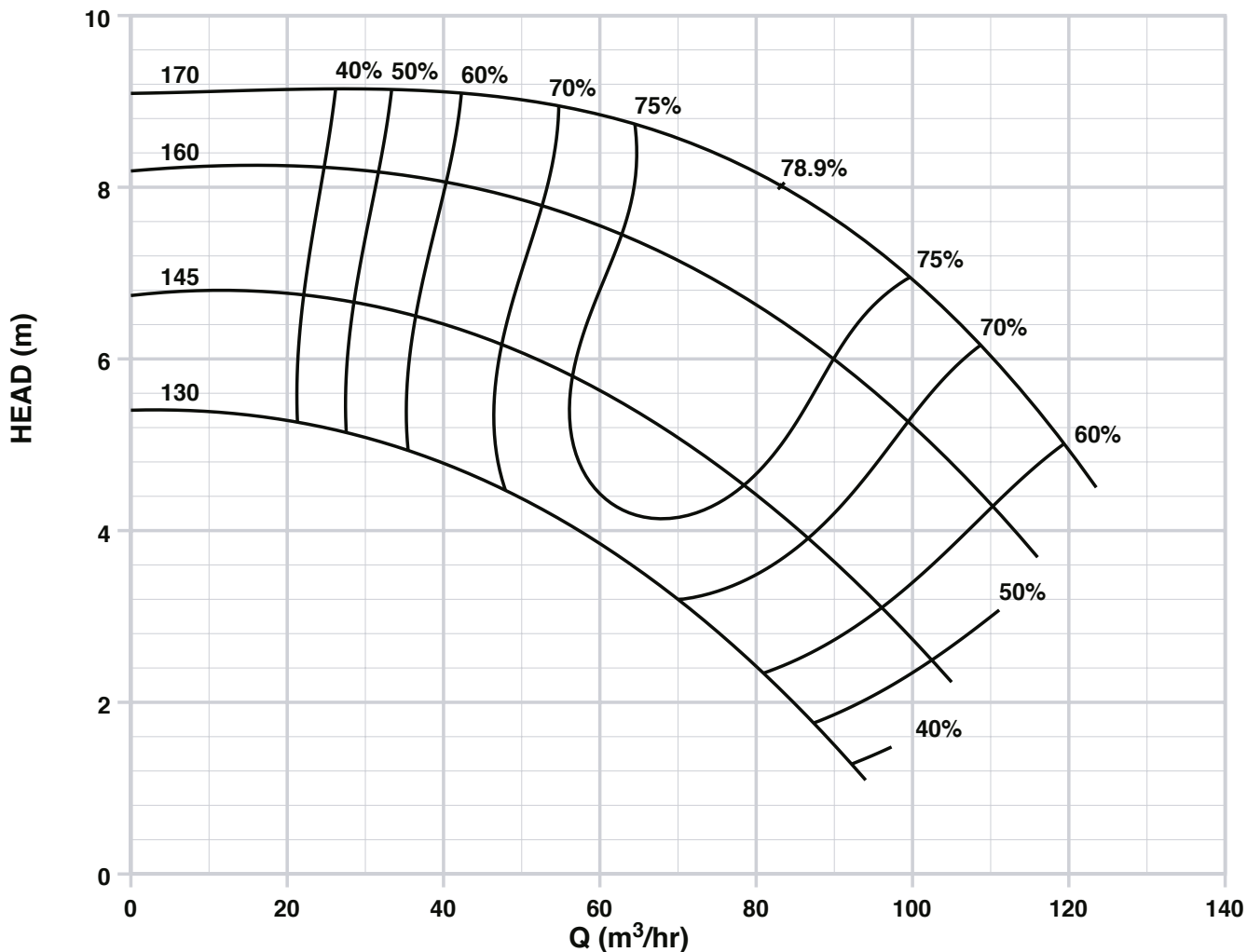

1450

CLT & CLB

MEDIUM-DUTY CENTRIFUGAL CHEMICAL PUMPS TO EN 733 (DIN 24256)



CHARACTERISTIC CURVE

Issue Date
OCTOBER 2005

Suction Diameter
125mm

Discharge Diameter
80mm

DIN 24 256
CLT 80-200

Based on water density 1000 kg/m³ and viscosity 1 cSt.
Head, capacity and efficiency according to ISO Standard 2548: 1973 Annex B

1450 rpm

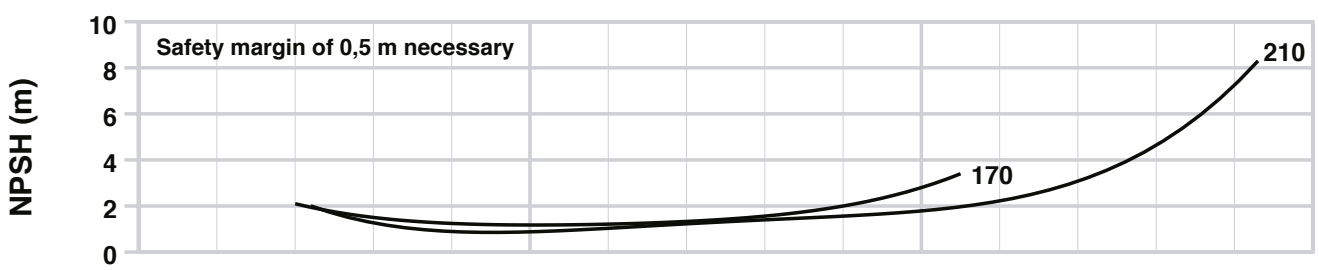
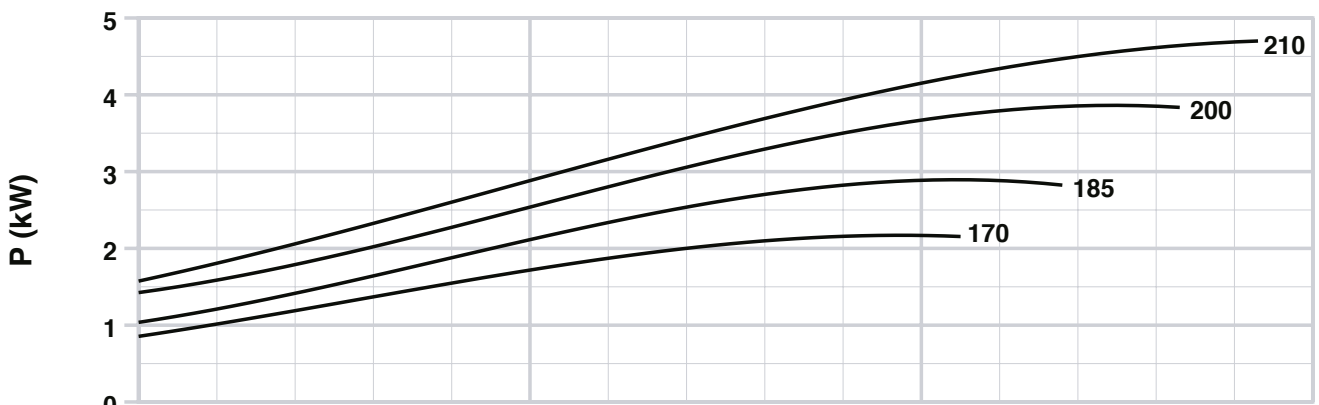
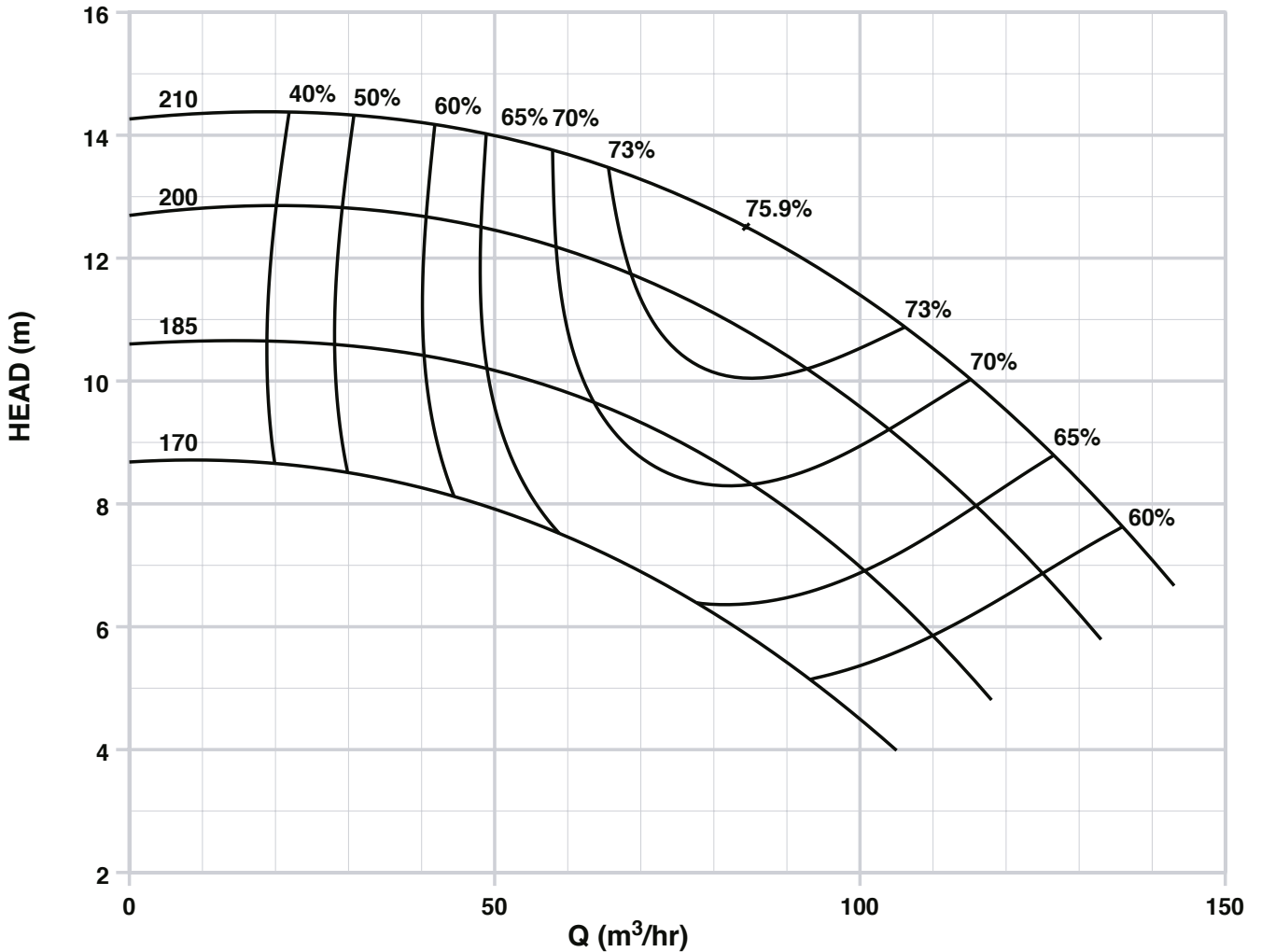

1450

CLT & CLB

MEDIUM-DUTY CENTRIFUGAL CHEMICAL PUMPS TO EN 733 (DIN 24256)



CHARACTERISTIC CURVE

Issue Date
OCTOBER 2005

Suction Diameter
125mm

Discharge Diameter
80mm

DIN 24 256
CLT 80- 250

Based on water density 1000 kg/m³ and viscosity 1 cSt.
Head, capacity and efficiency according to ISO Standard 2548: 1973 Annex B

1450 rpm

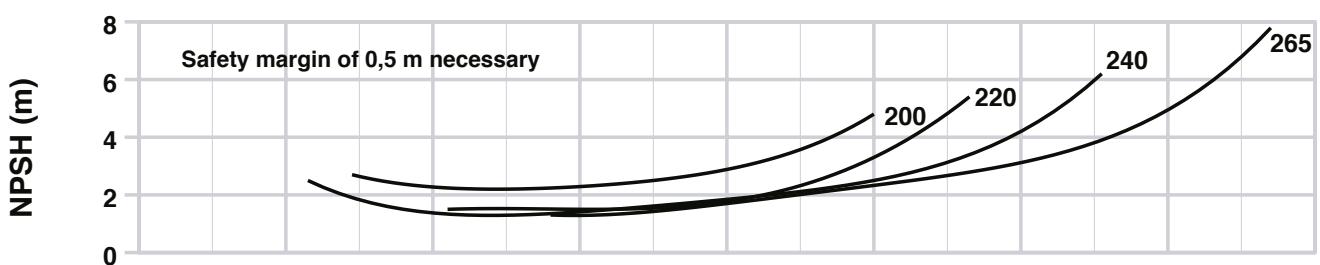
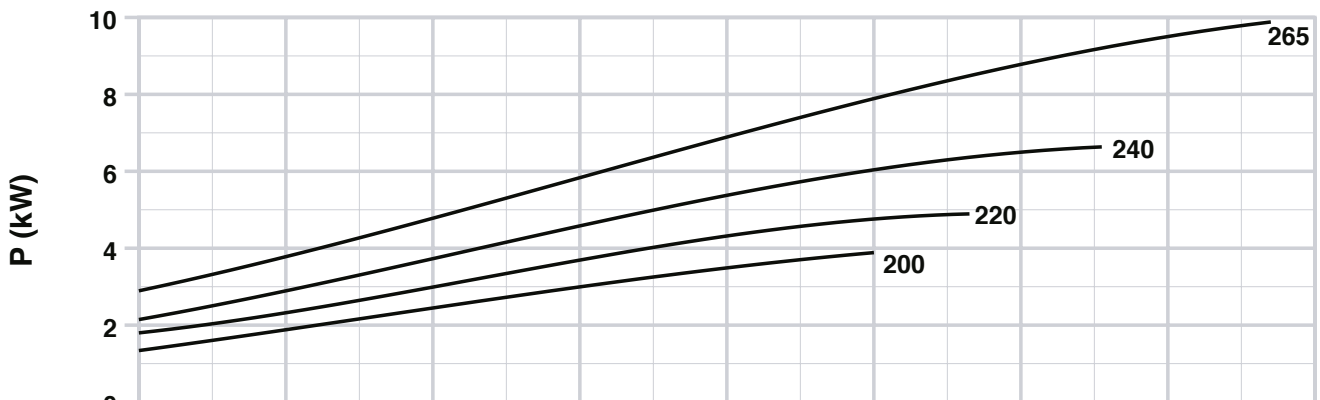
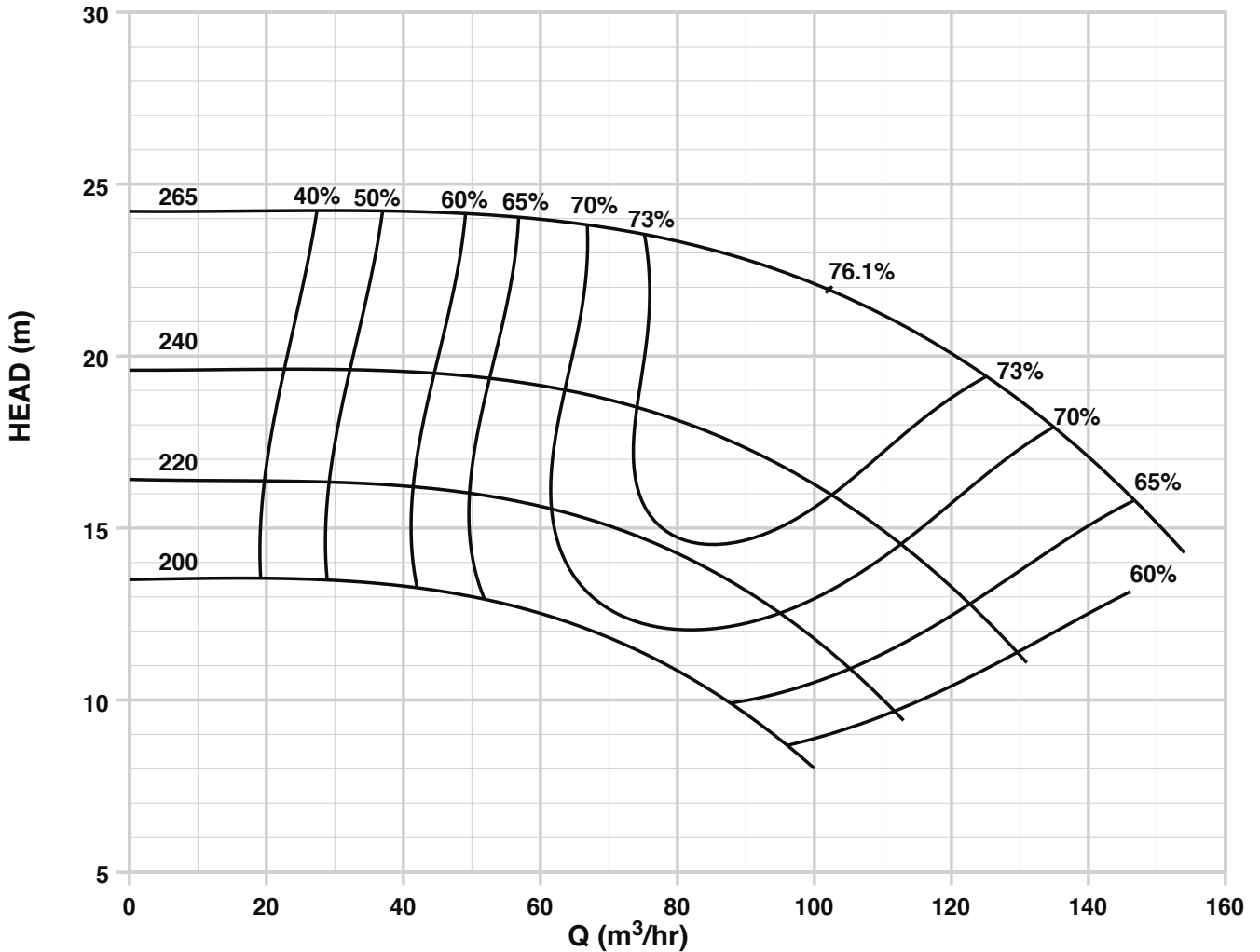

1450

CLT & CLB

MEDIUM-DUTY CENTRIFUGAL CHEMICAL PUMPS TO EN 733 (DIN 24256)



CHARACTERISTIC CURVE

Issue Date
OCTOBER 2005

Suction Diameter
125mm

Discharge Diameter
80mm

DIN 24 256
CLT 80-315

Based on water density 1000 kg/m³ and viscosity 1 cSt.
Head, capacity and efficiency according to ISO Standard 2548: 1973 Annex B

1450 rpm

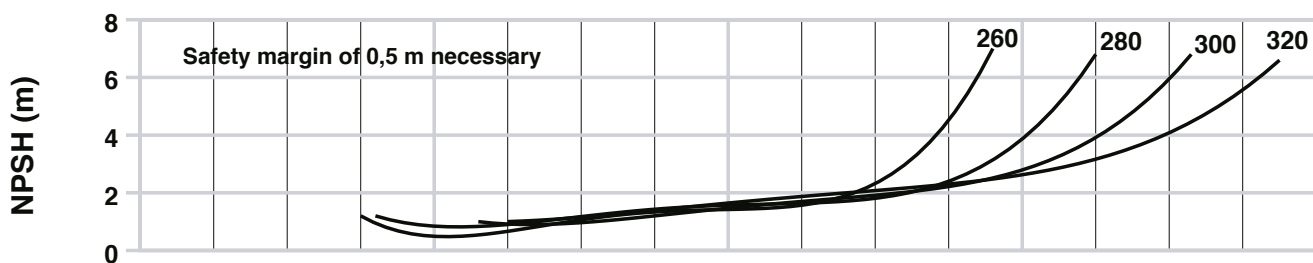
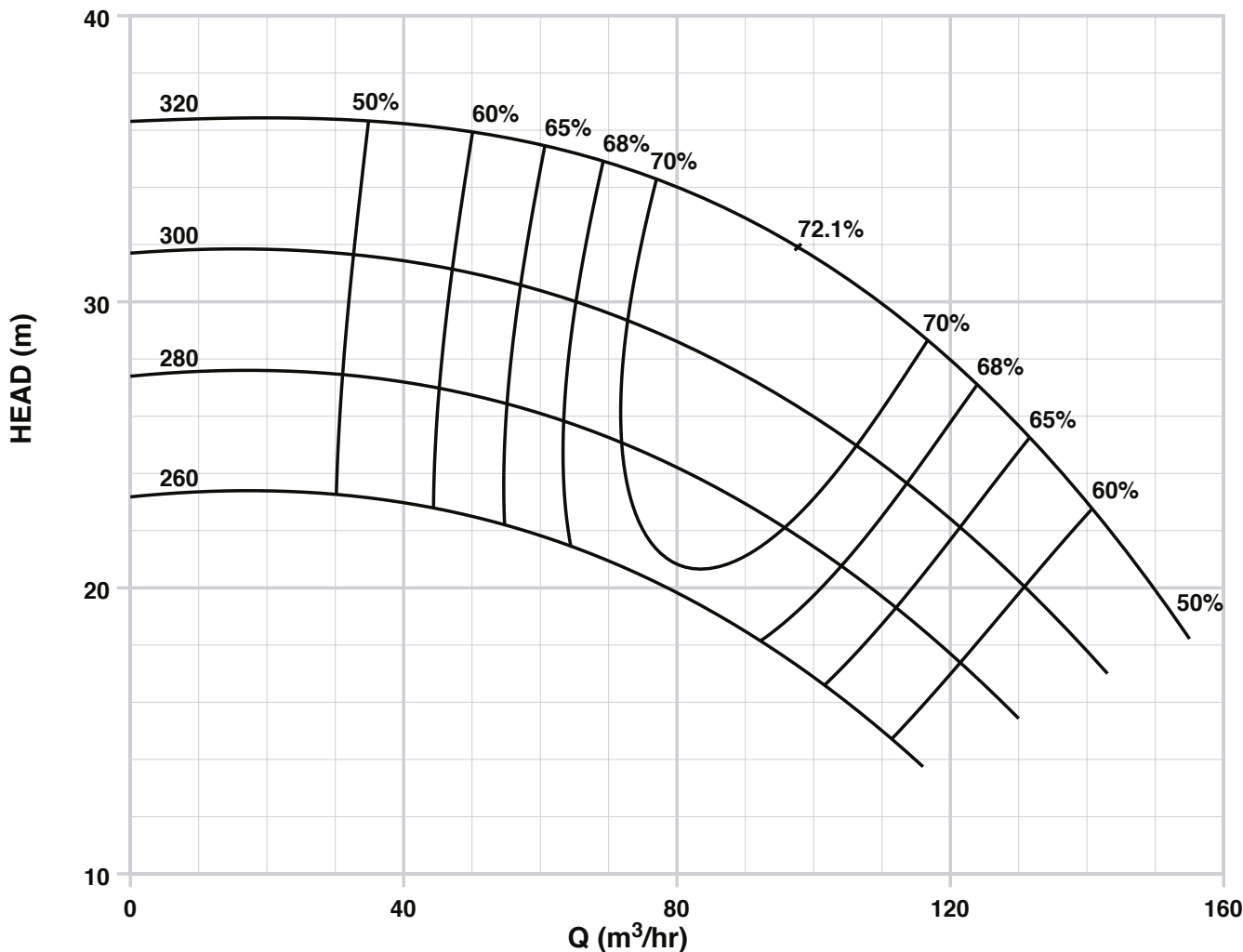

1450

CLT & CLB

MEDIUM-DUTY CENTRIFUGAL CHEMICAL PUMPS TO EN 733 (DIN 24256)



CHARACTERISTIC CURVE

Issue Date
OCTOBER 2005

Suction Diameter
125mm

Discharge Diameter
80mm

DIN 24 256
CLT 80-400

Based on water density 1000 kg/m³ and viscosity 1 cSt.
Head, capacity and efficiency according to ISO Standard 2548: 1973 Annex B

1450 rpm

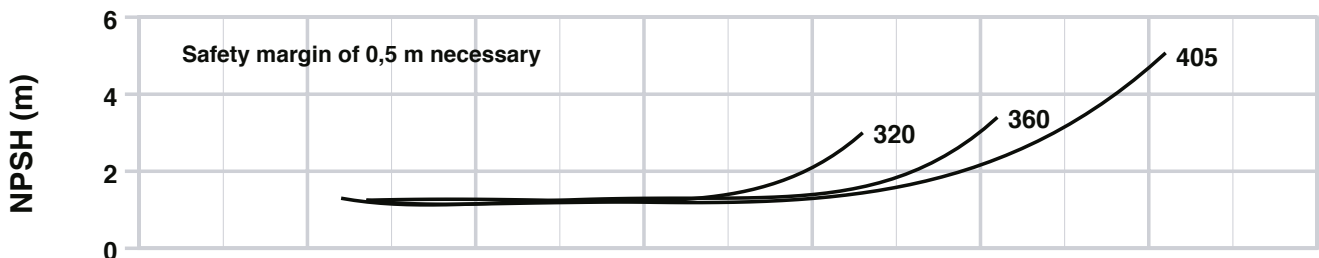
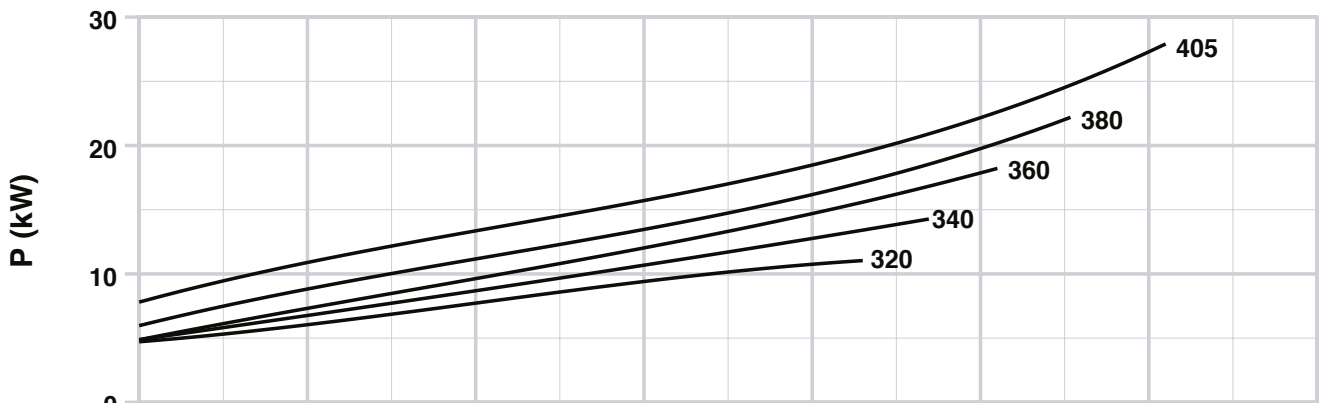
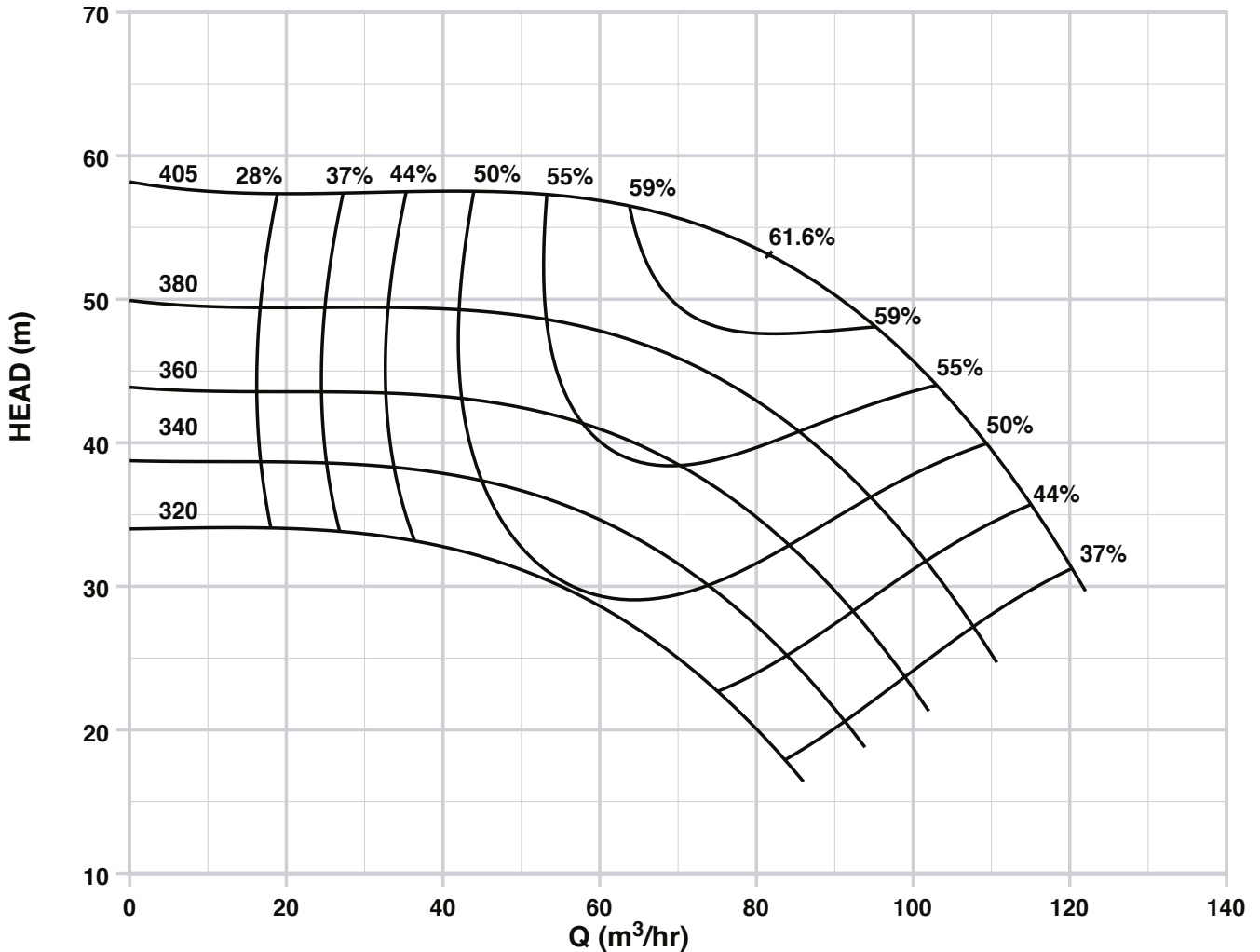

1450

CLT & CLB

MEDIUM-DUTY CENTRIFUGAL CHEMICAL PUMPS TO EN 733 (DIN 24256)



CHARACTERISTIC CURVE

Issue Date
OCTOBER 2005

Suction Diameter
125mm

Discharge Diameter
100mm

DIN 24 256
CLT 100-200

Based on water density 1000 kg/m³ and viscosity 1 cSt.
Head, capacity and efficiency according to ISO Standard 2548: 1973 Annex B

1450 rpm

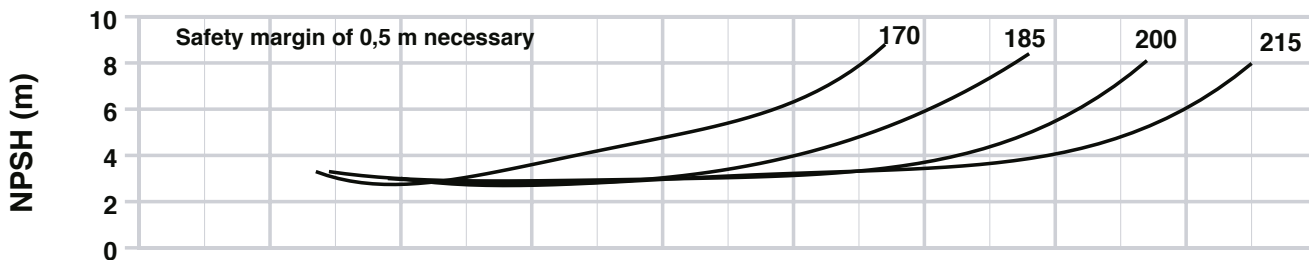
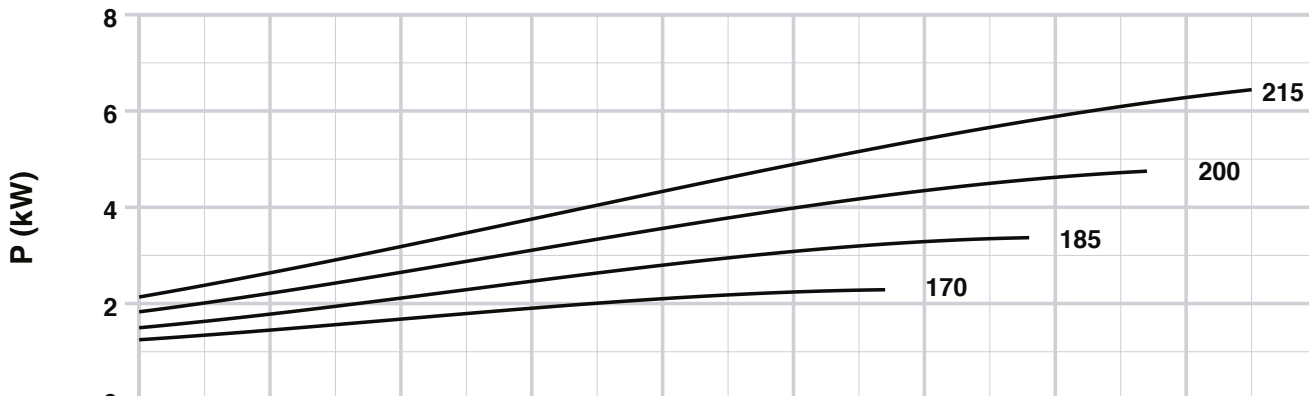
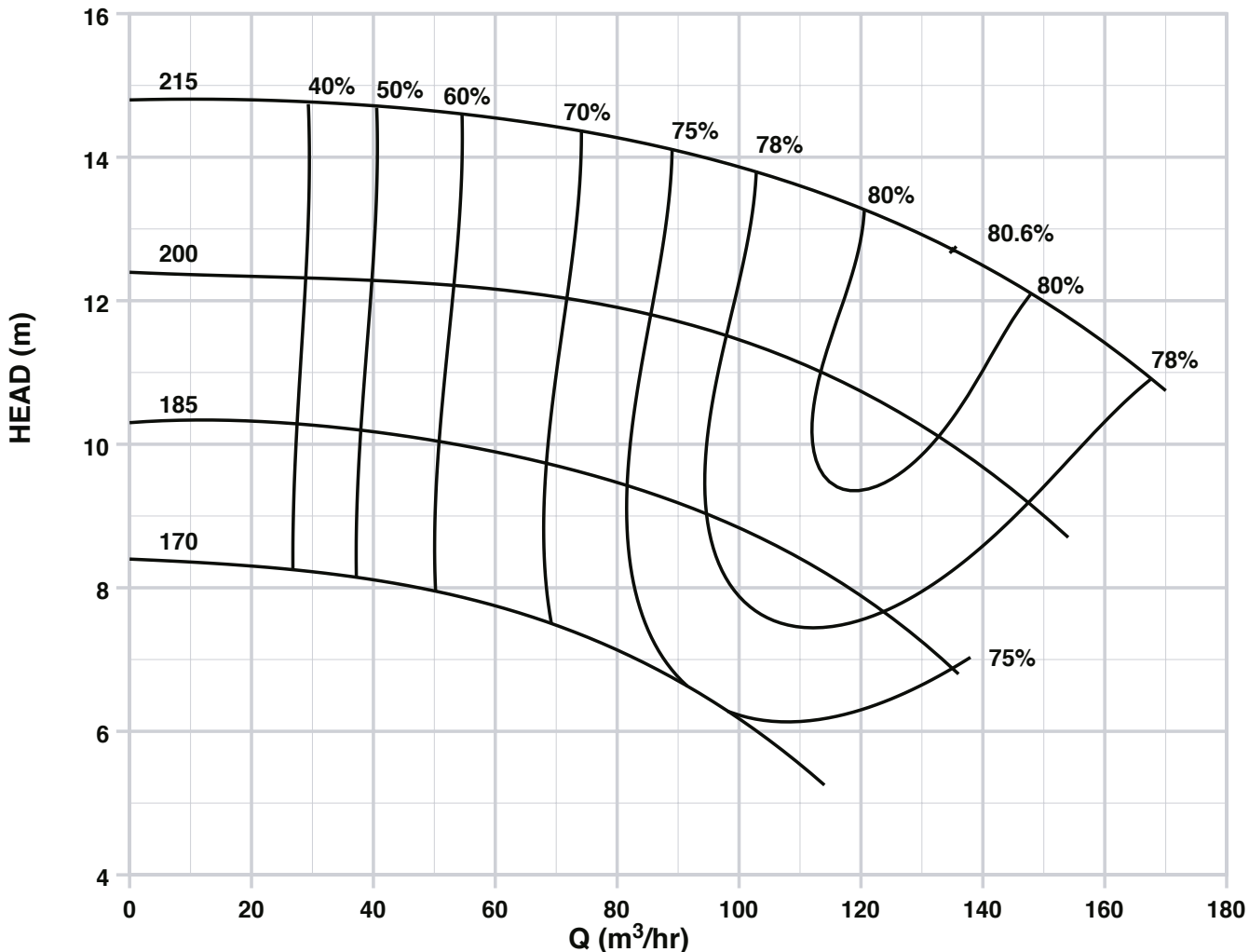

1450

CLT & CLB

MEDIUM-DUTY CENTRIFUGAL CHEMICAL PUMPS TO EN 733 (DIN 24256)

	CHARACTERISTIC CURVE		DIN 24 256	
	Issue Date OCTOBER 2005	Suction Diameter 125mm	Discharge Diameter 100mm	CLT 100-250
	Based on water density 1000 kg/m ³ and viscosity 1 cSt. Head, capacity and efficiency according to ISO Standard 2548: 1973 Annex B			1450 rpm

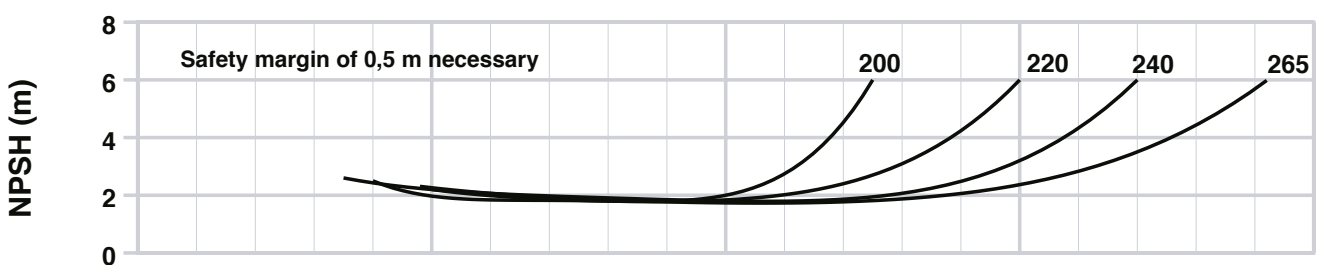
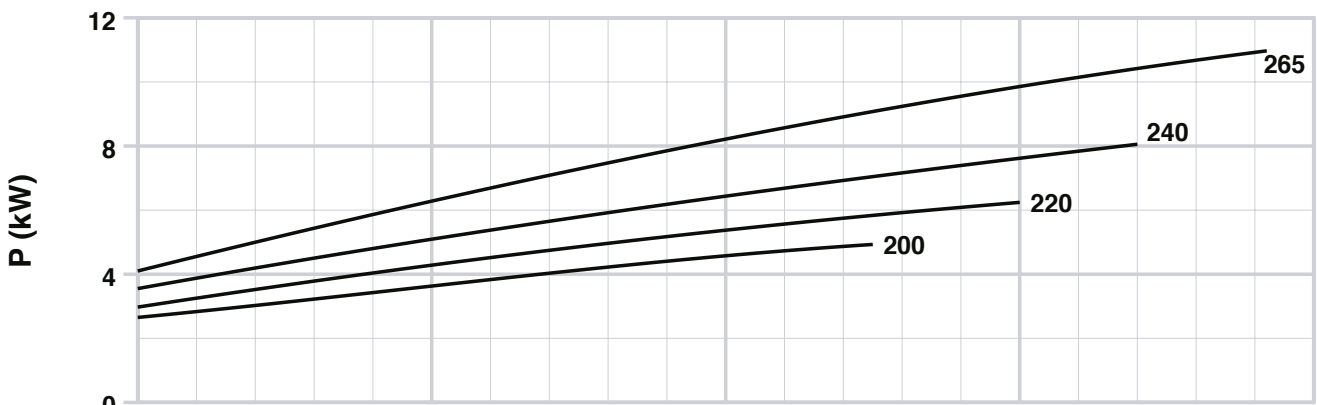
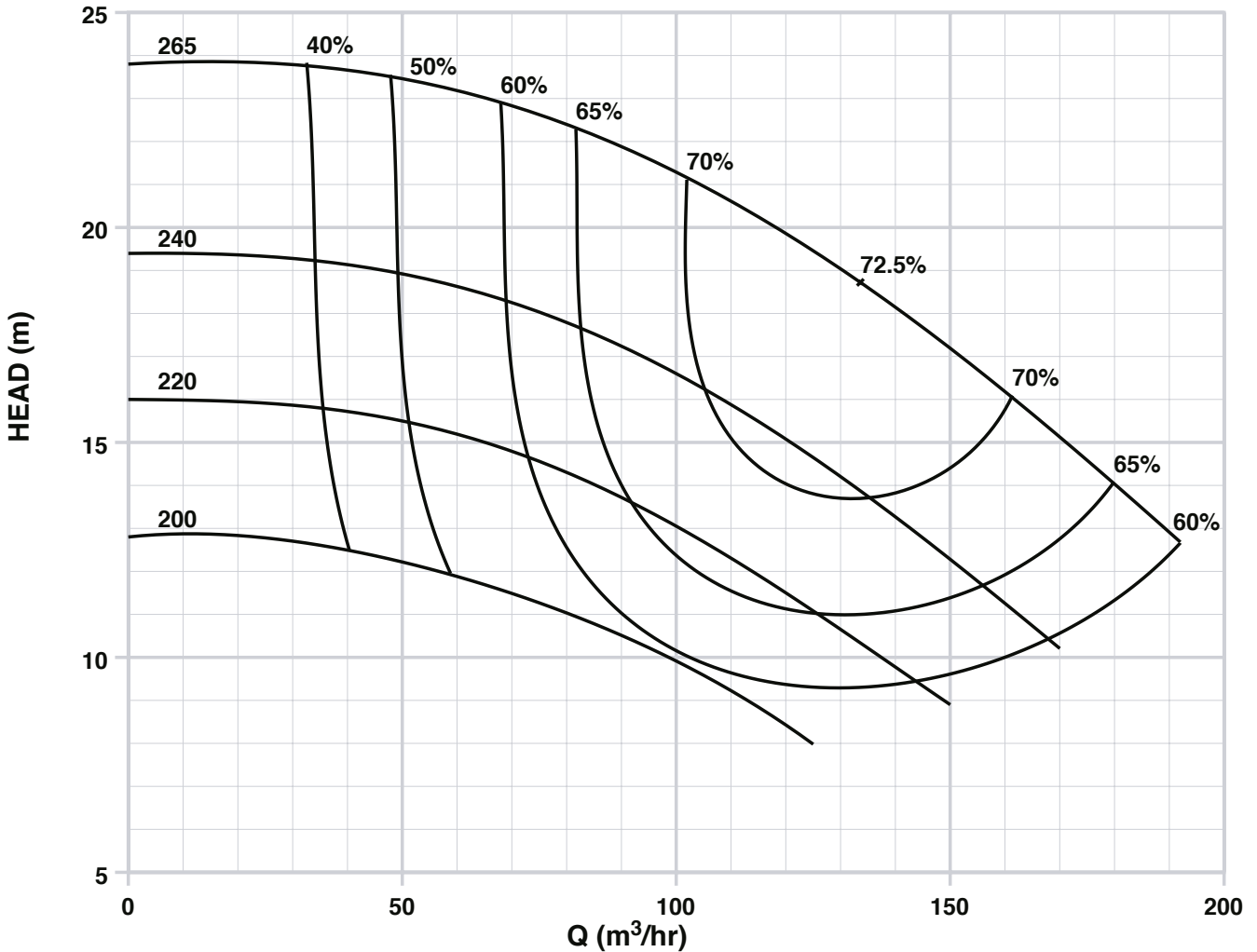

1450

CLT & CLB

MEDIUM-DUTY CENTRIFUGAL CHEMICAL PUMPS TO EN 733 (DIN 24256)



CHARACTERISTIC CURVE

DIN 24 256
CLT 100-315

Issue Date
OCTOBER 2005

Suction Diameter
125mm

Discharge Diameter
100mm

Based on water density 1000 kg/m³ and viscosity 1 cSt.
Head, capacity and efficiency according to ISO Standard 2548: 1973 Annex B

1450 rpm

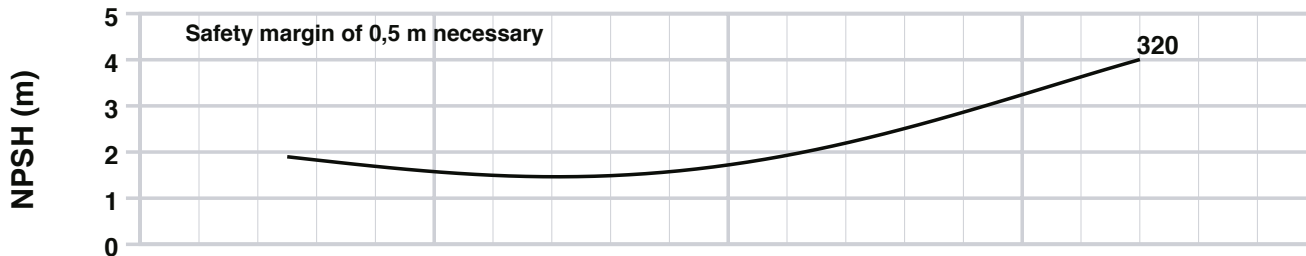
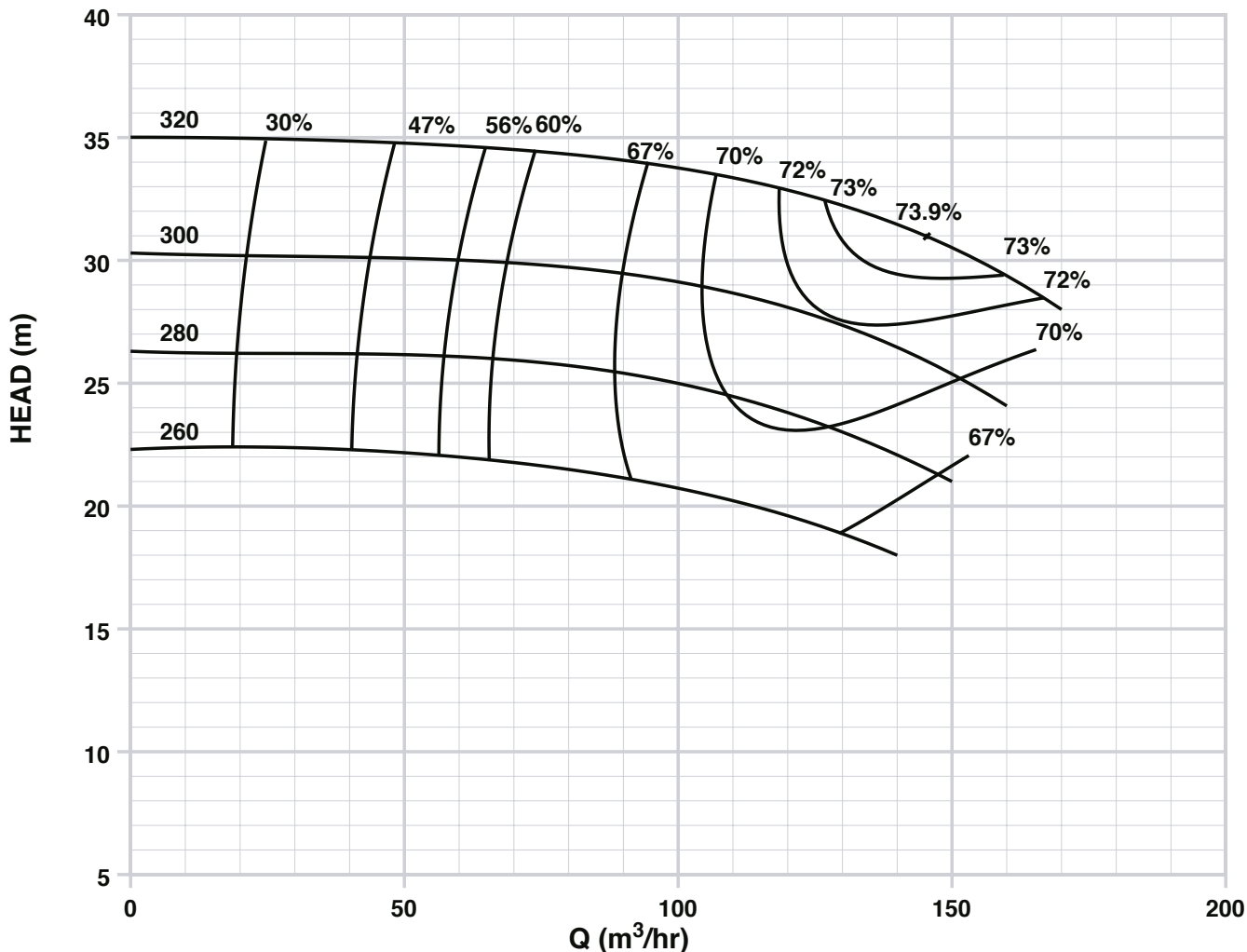

1450

CLT & CLB

MEDIUM-DUTY CENTRIFUGAL CHEMICAL PUMPS TO EN 733 (DIN 24256)



CHARACTERISTIC CURVE

Issue Date
OCTOBER 2005

Suction Diameter
125mm

Discharge Diameter
100mm

DIN 24 256
CLT 100-400

Based on water density 1000 kg/m³ and viscosity 1 cSt.
Head, capacity and efficiency according to ISO Standard 2548: 1973 Annex B

1450 rpm

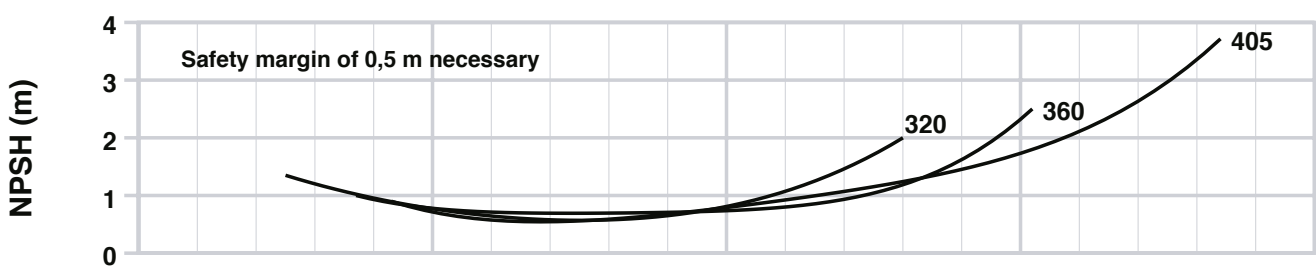
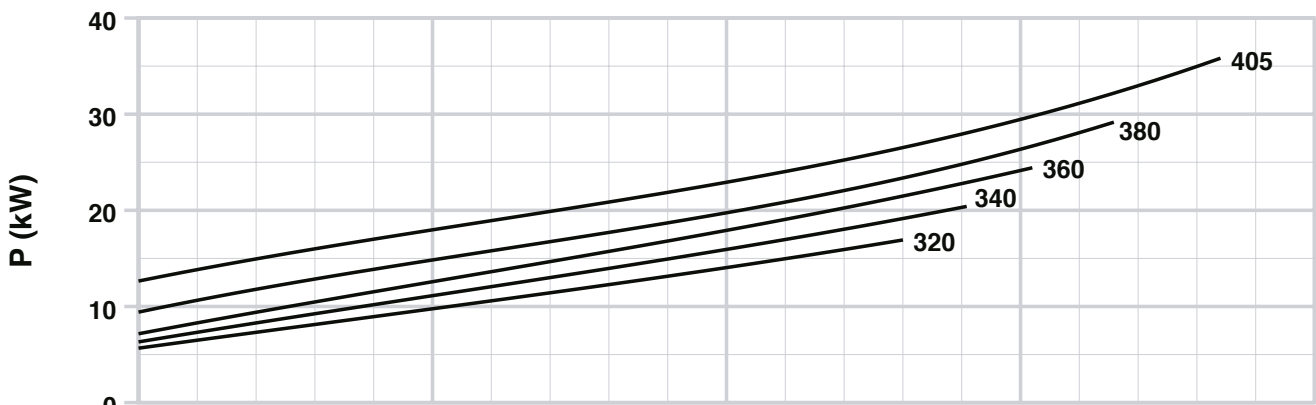
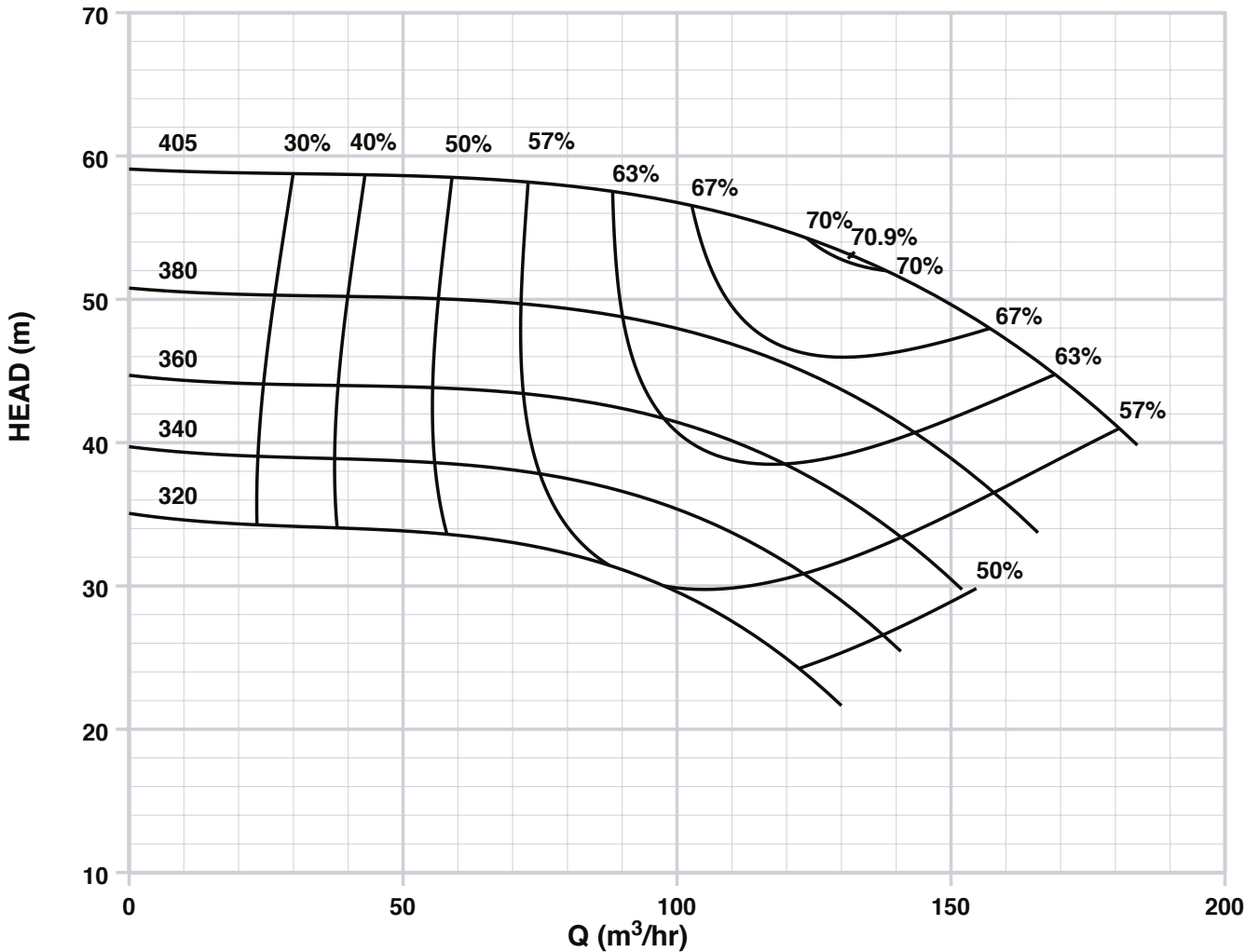

1450

CLT & CLB

MEDIUM-DUTY CENTRIFUGAL CHEMICAL PUMPS TO EN 733 (DIN 24256)



CHARACTERISTIC CURVE

Issue Date
OCTOBER 2005

Suction Diameter
150mm

Discharge Diameter
125mm

DIN 24 256
CLT 125-250

Based on water density 1000 kg/m³ and viscosity 1 cSt.
Head, capacity and efficiency according to ISO Standard 2548: 1973 Annex B

1450 rpm

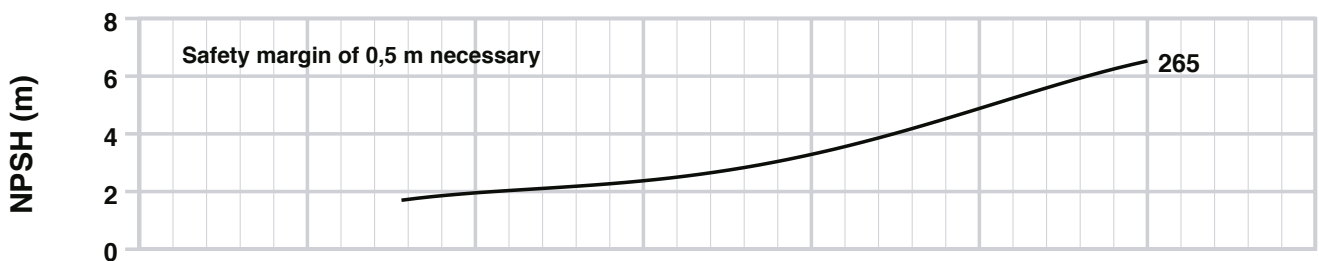
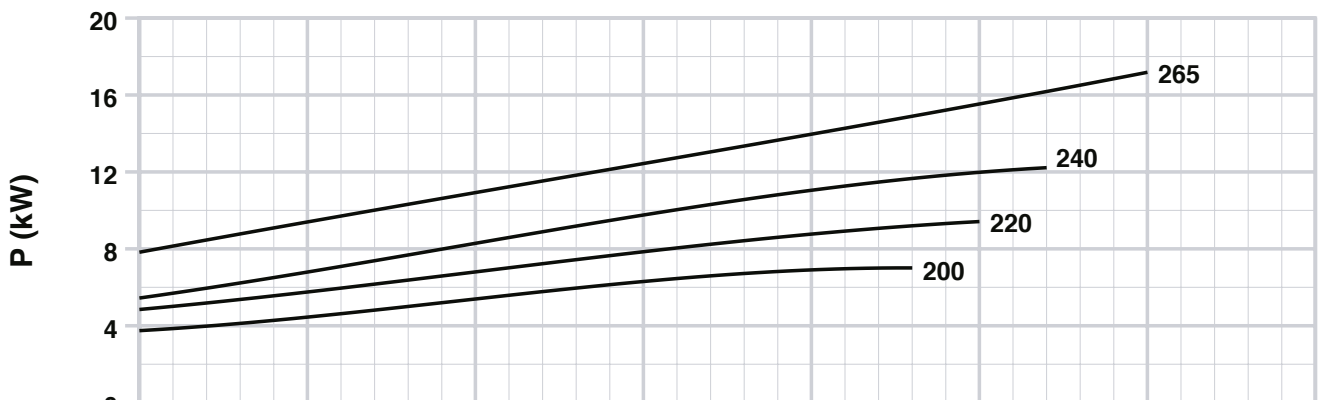
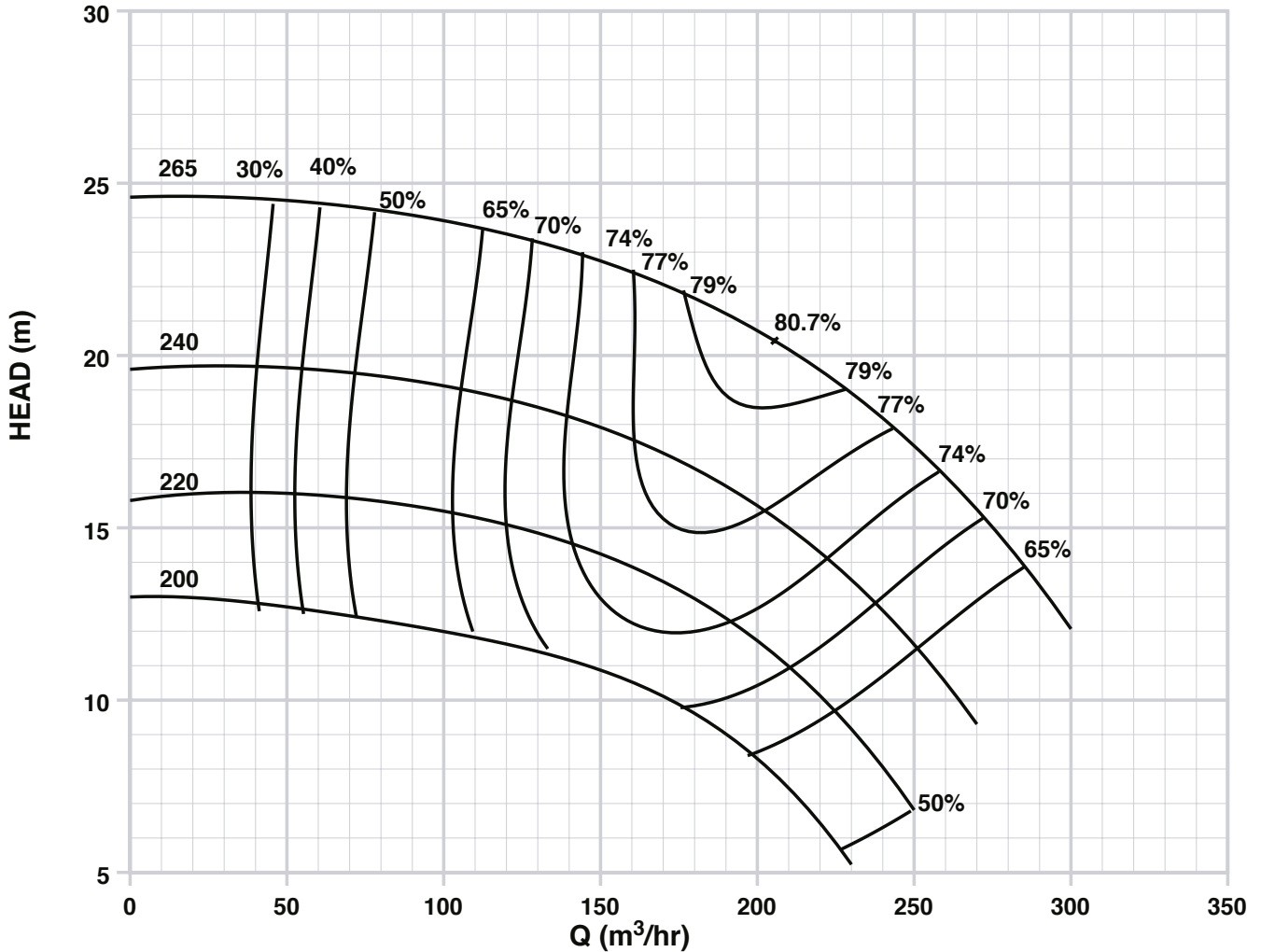

1450

CLT & CLB

MEDIUM-DUTY CENTRIFUGAL CHEMICAL PUMPS TO EN 733 (DIN 24256)

	CHARACTERISTIC CURVE			DIN 24 256
	Issue Date OCTOBER 2005	Suction Diameter 150mm	Discharge Diameter 125mm	CLT 125-315
	Based on water density 1000 kg/m ³ and viscosity 1 cSt. Head, capacity and efficiency according to ISO Standard 2548: 1973 Annex B			1450 rpm

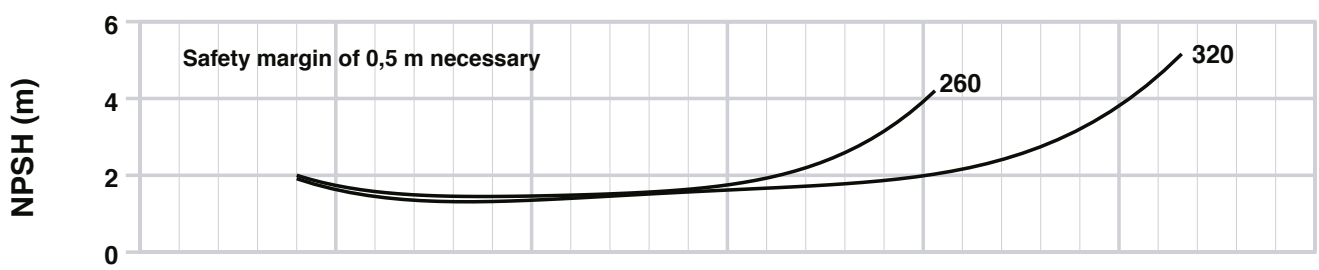
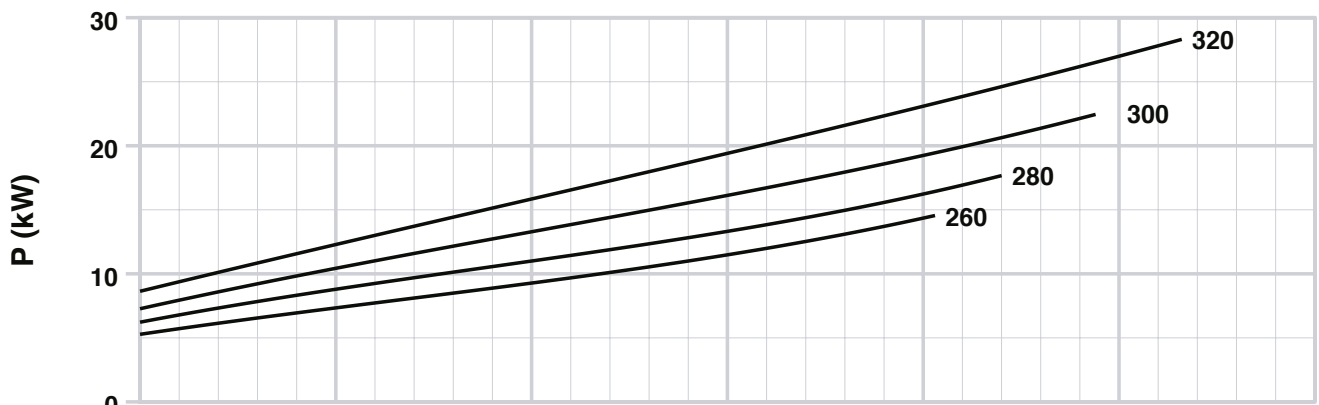
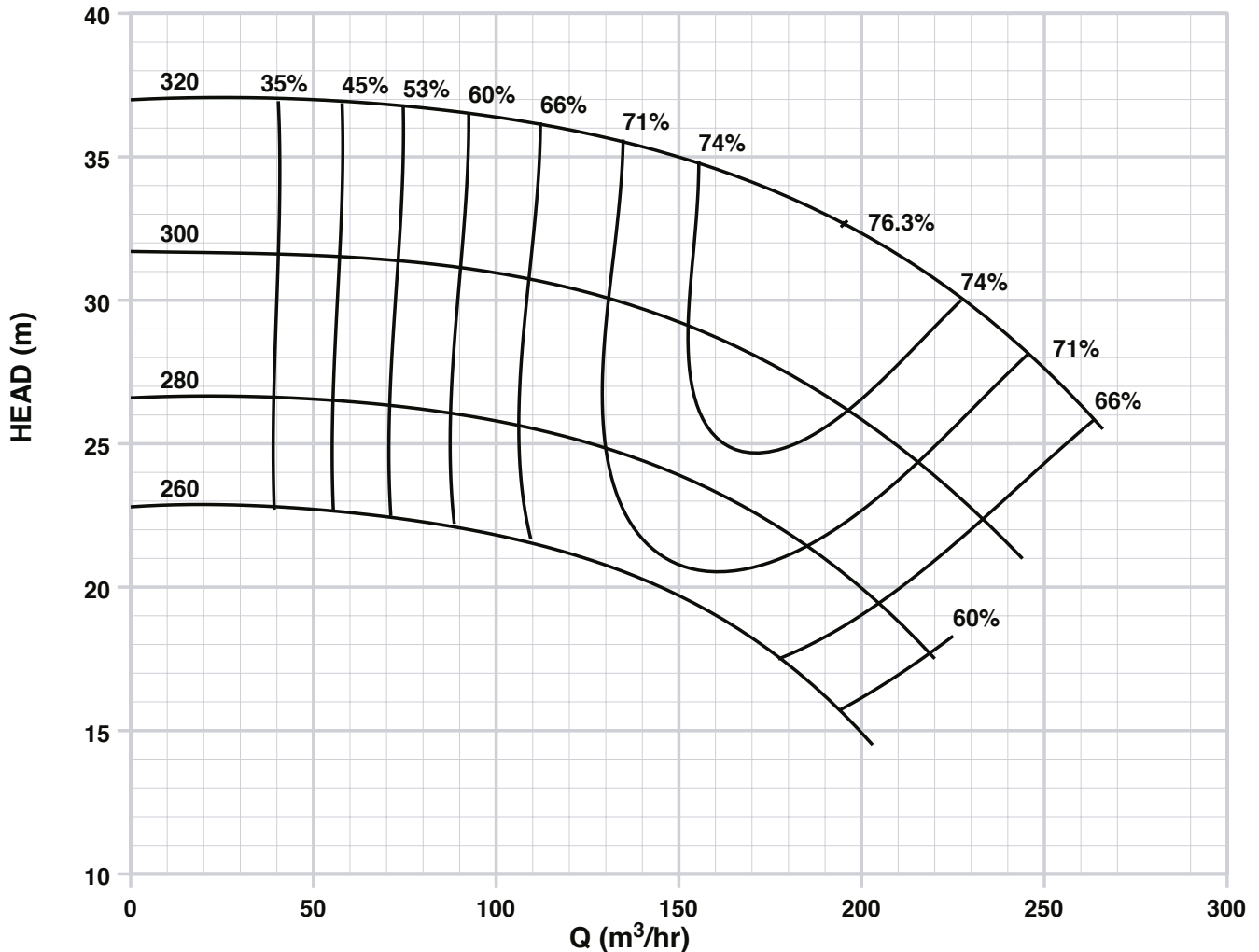

1450

CLT & CLB

MEDIUM-DUTY CENTRIFUGAL CHEMICAL PUMPS TO EN 733 (DIN 24256)



CHARACTERISTIC CURVE

Issue Date
OCTOBER 2005

Suction Diameter
150mm

Discharge Diameter
125mm

DIN 24 256
CLT 125-400

Based on water density 1000 kg/m³ and viscosity 1 cSt.
Head, capacity and efficiency according to ISO Standard 2548: 1973 Annex B

1450 rpm

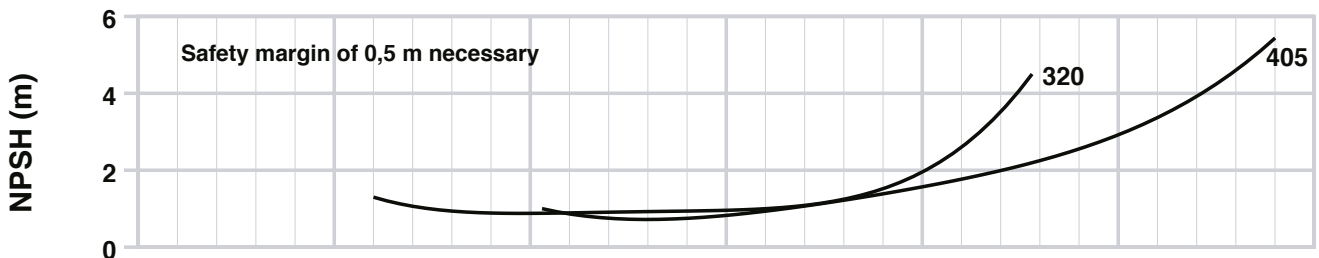
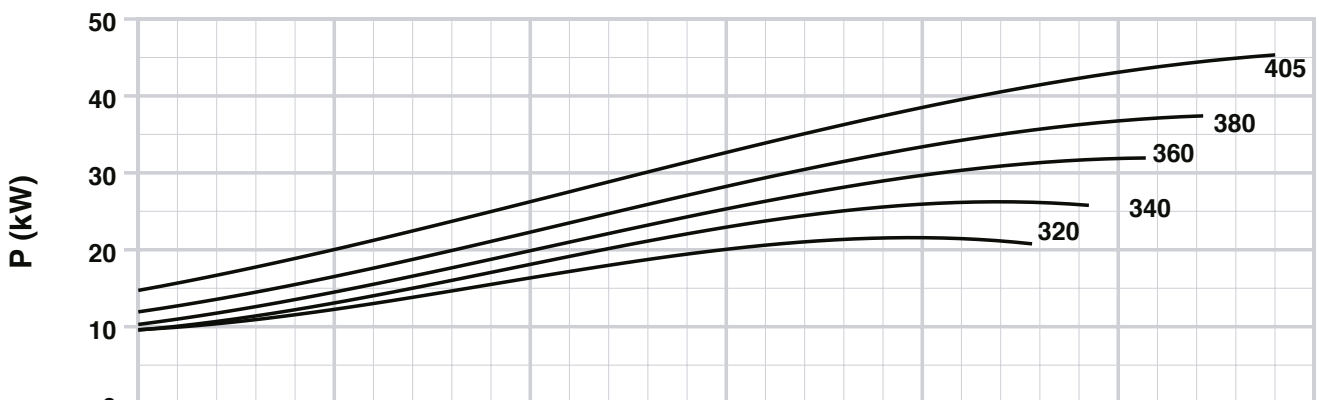
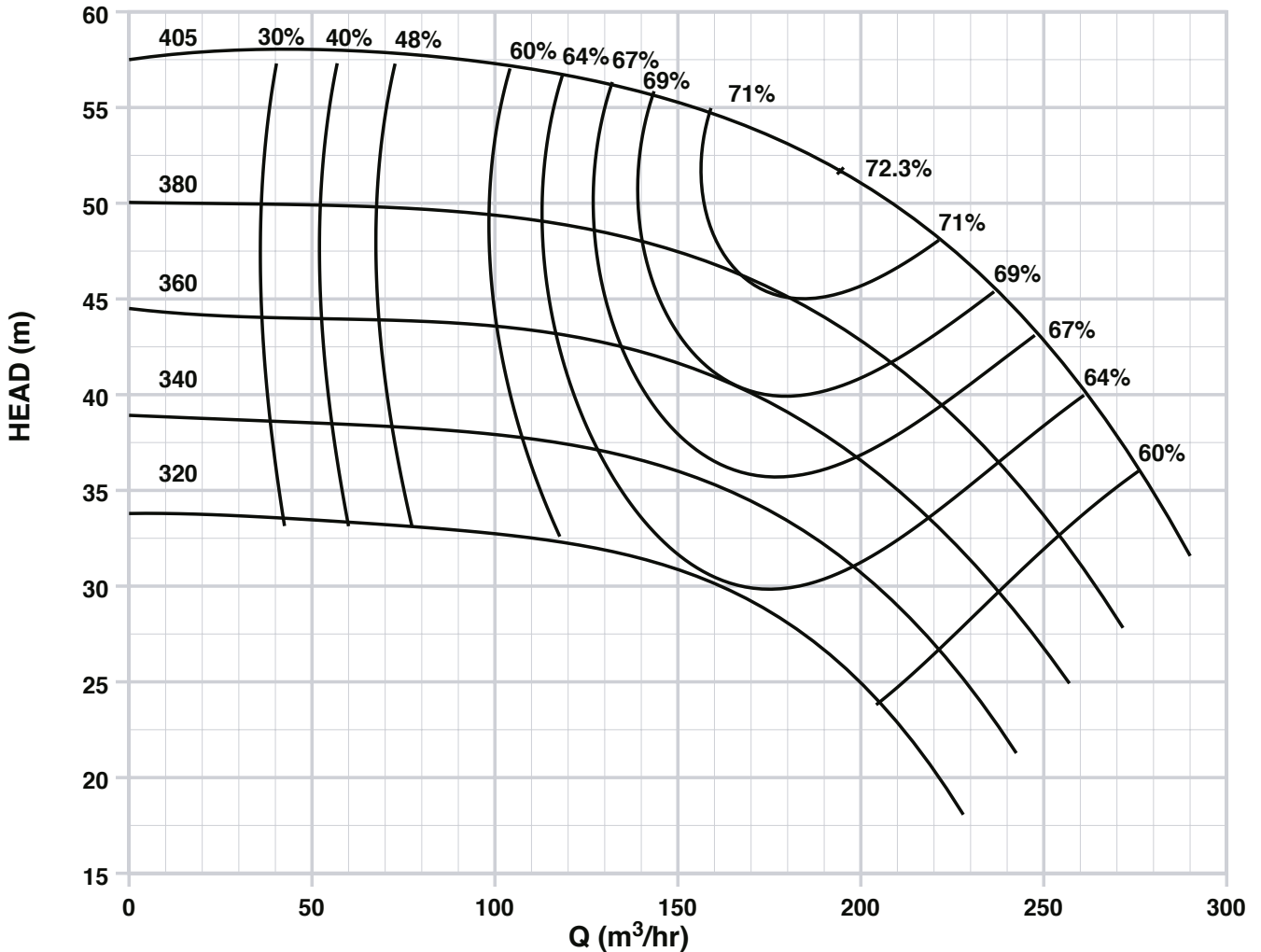

1450

CLT & CLB

MEDIUM-DUTY CENTRIFUGAL CHEMICAL PUMPS TO EN 733 (DIN 24256)



CHARACTERISTIC CURVE

Issue Date
OCTOBER 2005

Suction Diameter
200mm

Discharge Diameter
150mm

DIN 24 256
CLT 150-250

Based on water density 1000 kg/m³ and viscosity 1 cSt.
Head, capacity and efficiency according to ISO Standard 2548: 1973 Annex B

1450 rpm

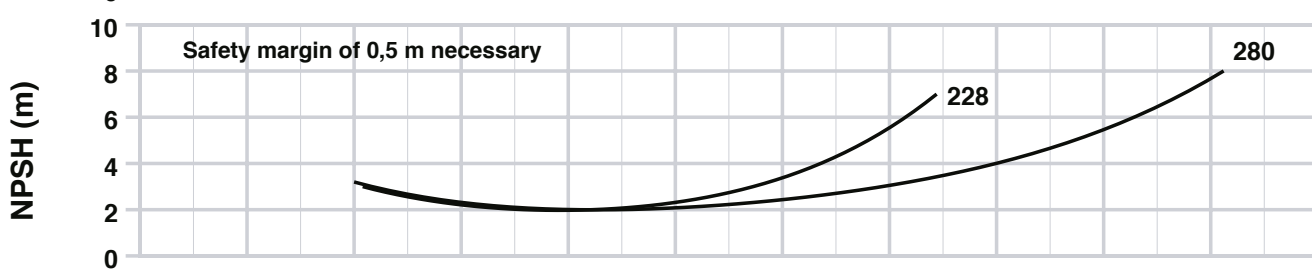
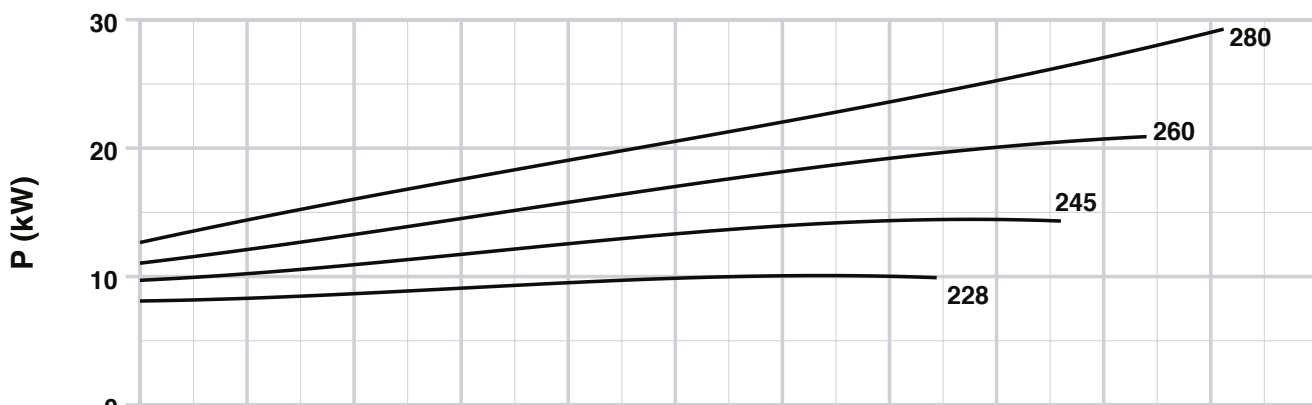
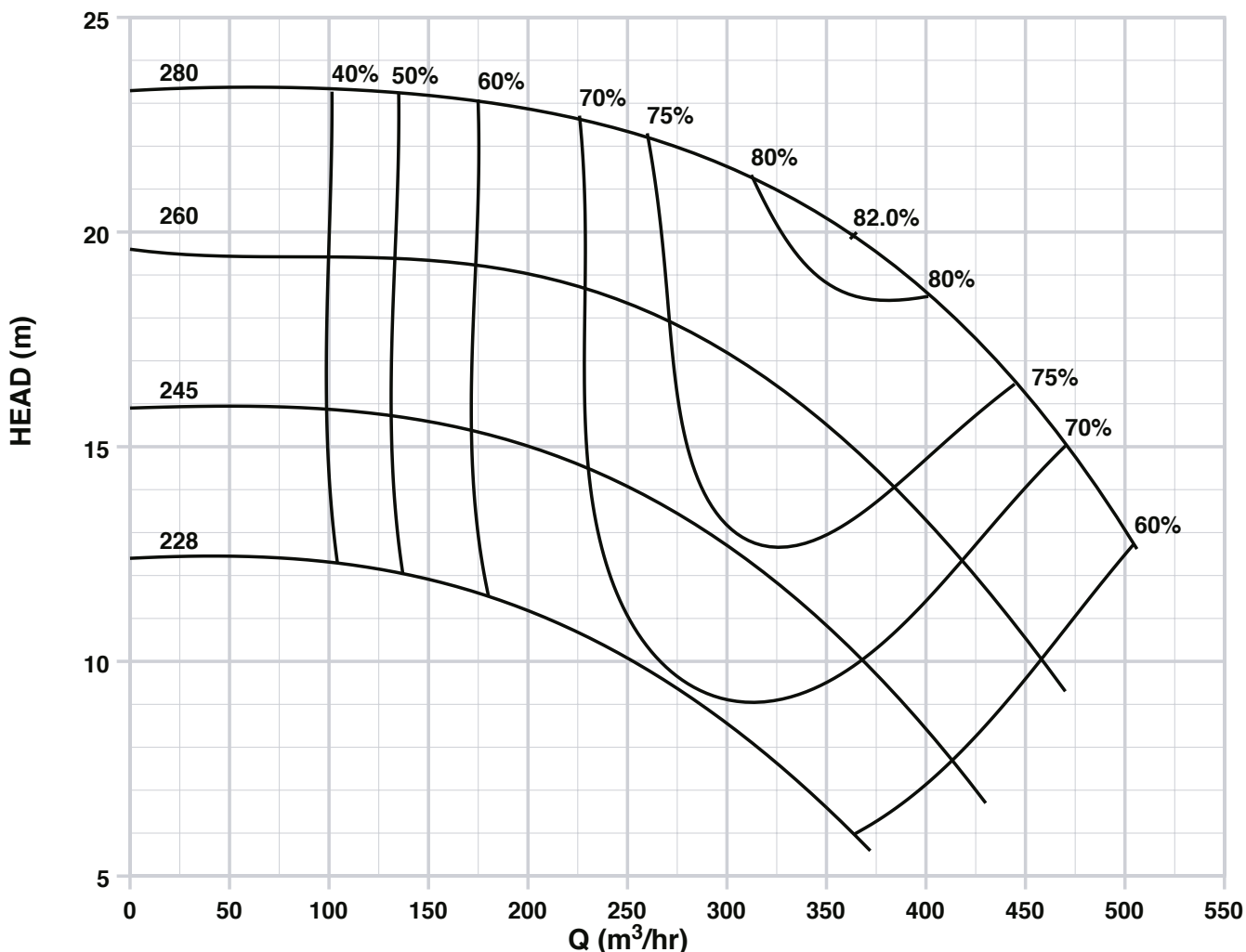

1450

CLT & CLB

MEDIUM-DUTY CENTRIFUGAL CHEMICAL PUMPS TO EN 733 (DIN 24256)



CHARACTERISTIC CURVE

Issue Date
OCTOBER 2005

Suction Diameter
200mm

Discharge Diameter
150mm

DIN 24 256
CLT 150-315

Based on water density 1000 kg/m³ and viscosity 1 cSt.
Head, capacity and efficiency according to ISO Standard 2548: 1973 Annex B

1450 rpm

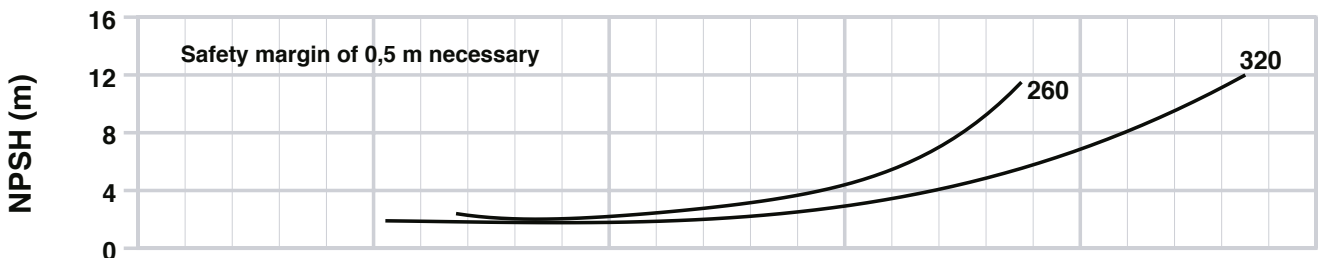
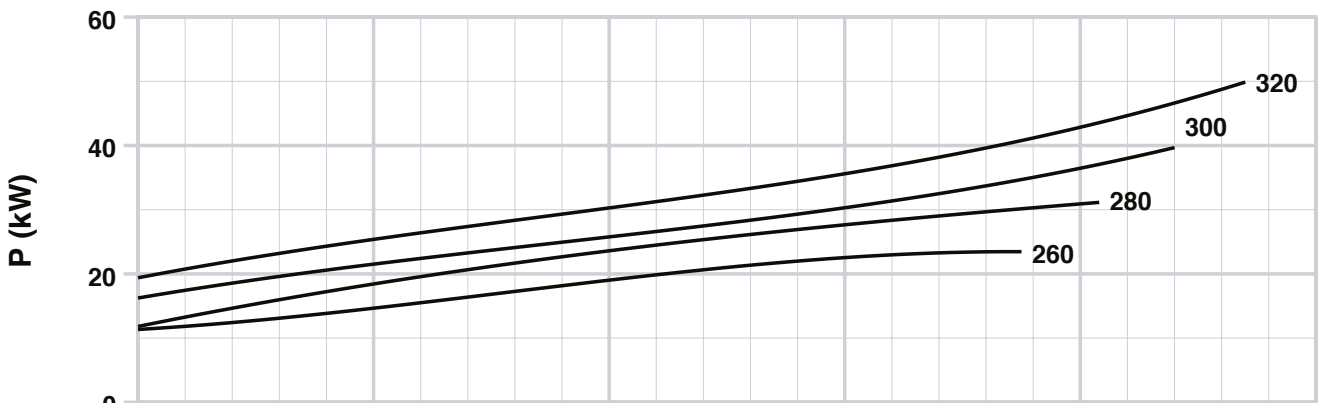
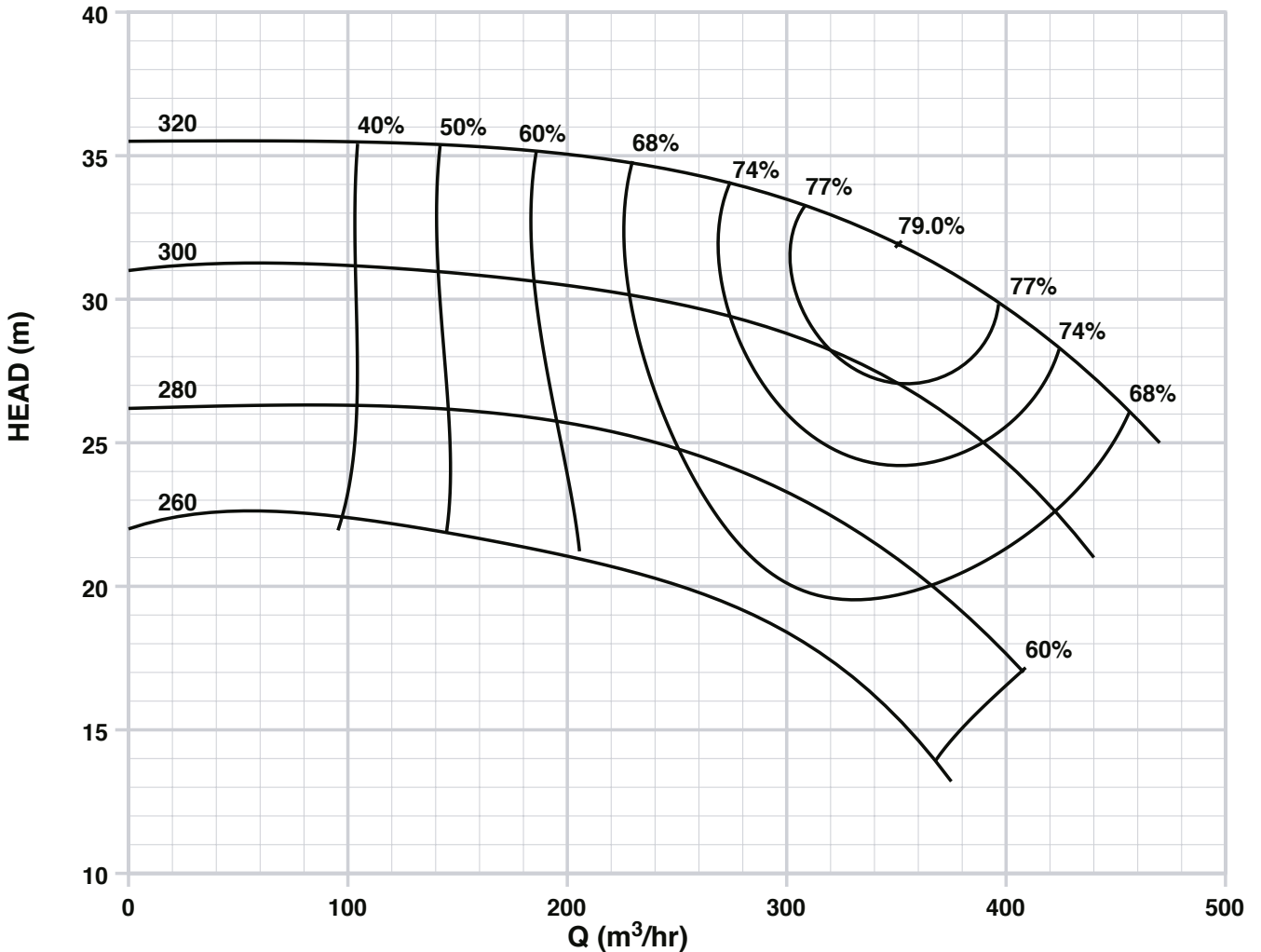

1450

CLT & CLB

MEDIUM-DUTY CENTRIFUGAL CHEMICAL PUMPS TO EN 733 (DIN 24256)



CHARACTERISTIC CURVE

Issue Date
OCTOBER 2005

Suction Diameter
200mm

Discharge Diameter
150mm

DIN 24 256
CLT 150-400

Based on water density 1000 kg/m³ and viscosity 1 cSt.
Head, capacity and efficiency according to ISO Standard 2548: 1973 Annex B

1450 rpm

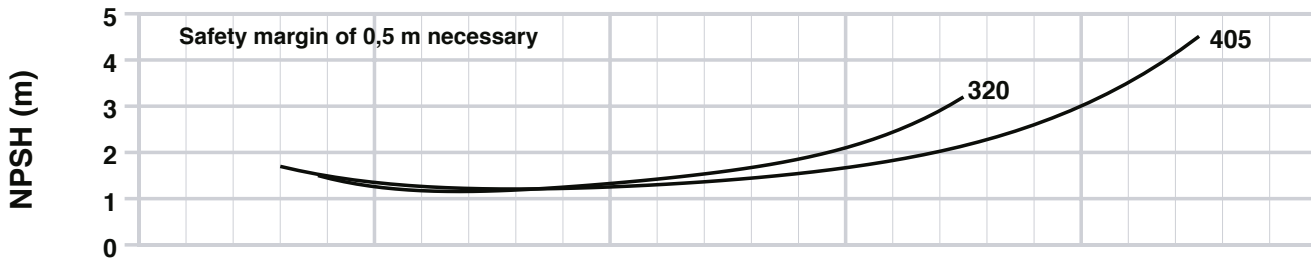
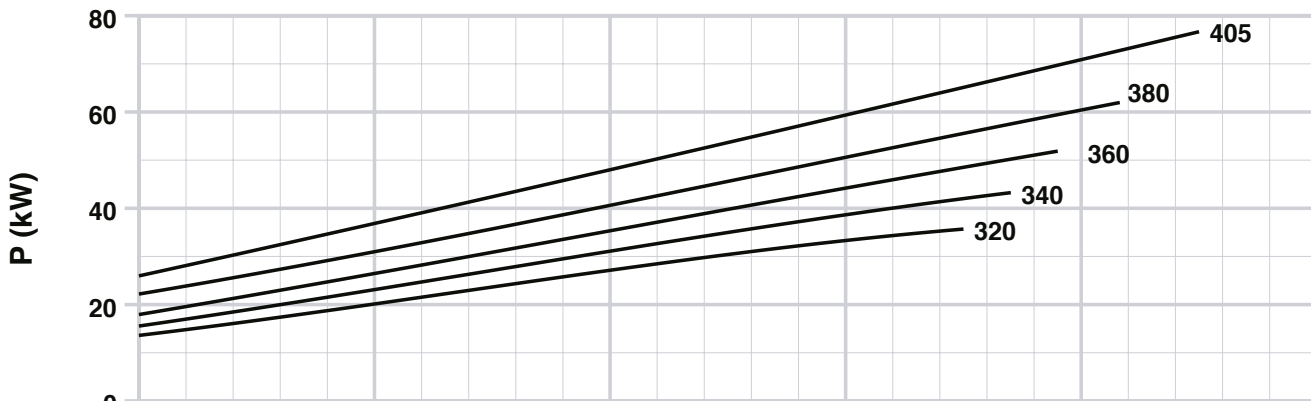
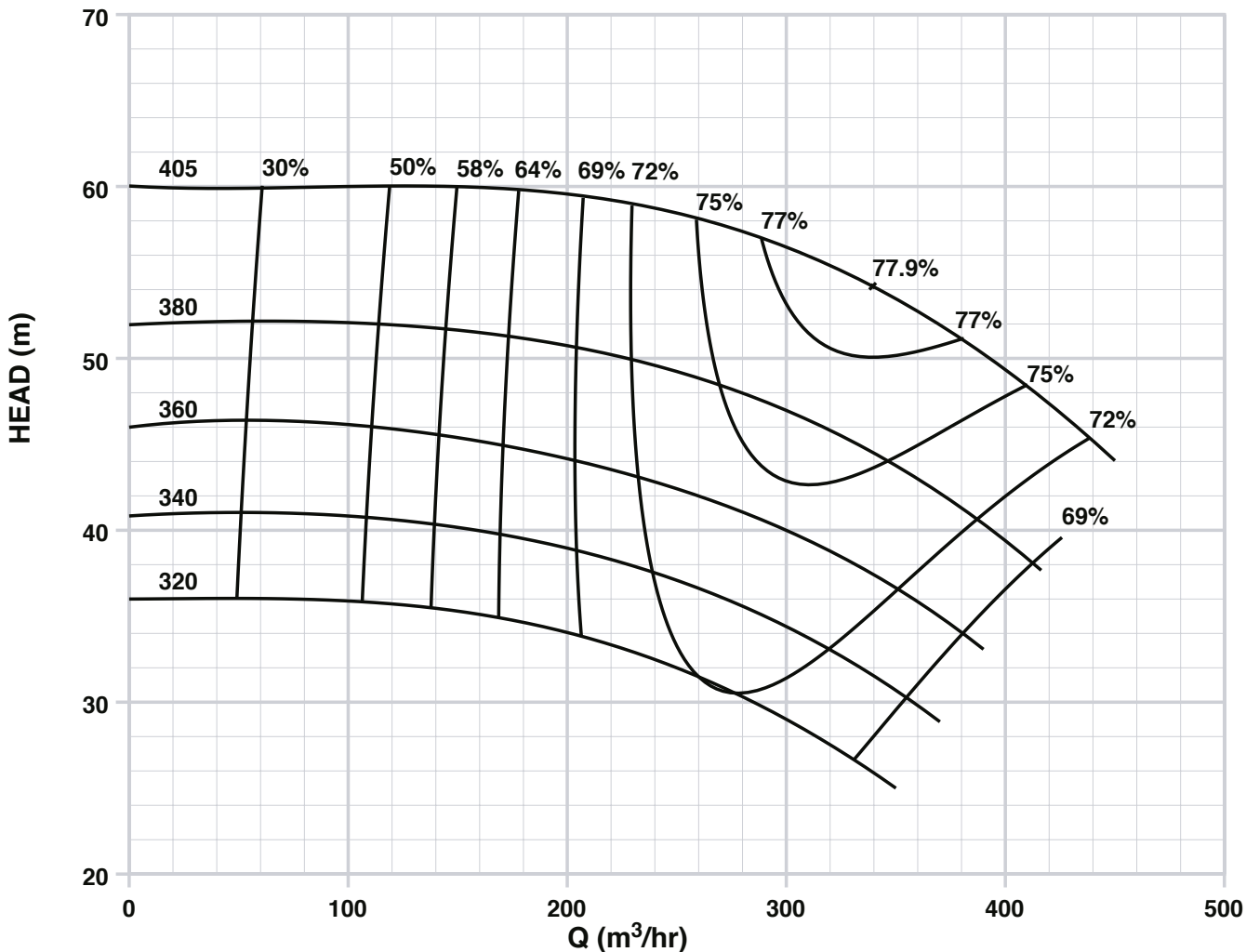

1450

CLT & CLB

MEDIUM-DUTY CENTRIFUGAL CHEMICAL PUMPS TO EN 733 (DIN 24256)



CHARACTERISTIC CURVE

DIN 24 256
CLT 150-500

Issue Date
OCTOBER 2005

Suction Diameter
2000mm

Discharge Diameter
150mm

Based on water density 1000 kg/m³ and viscosity 1 cSt.
Head, capacity and efficiency according to ISO Standard 2548: 1973 Annex B

1450 rpm

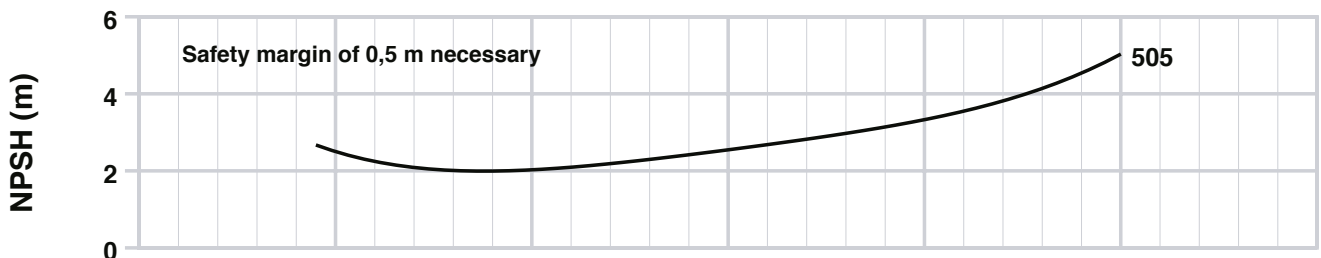
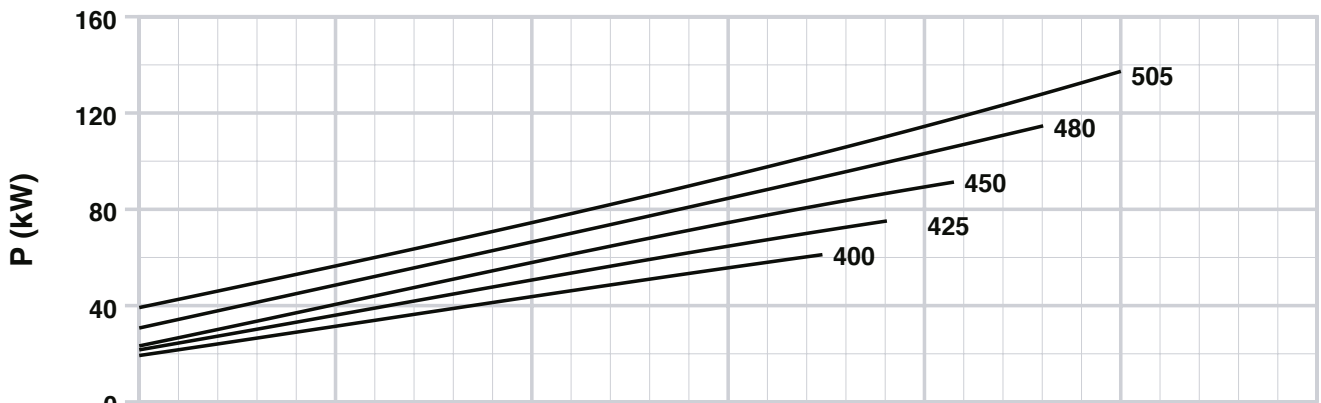
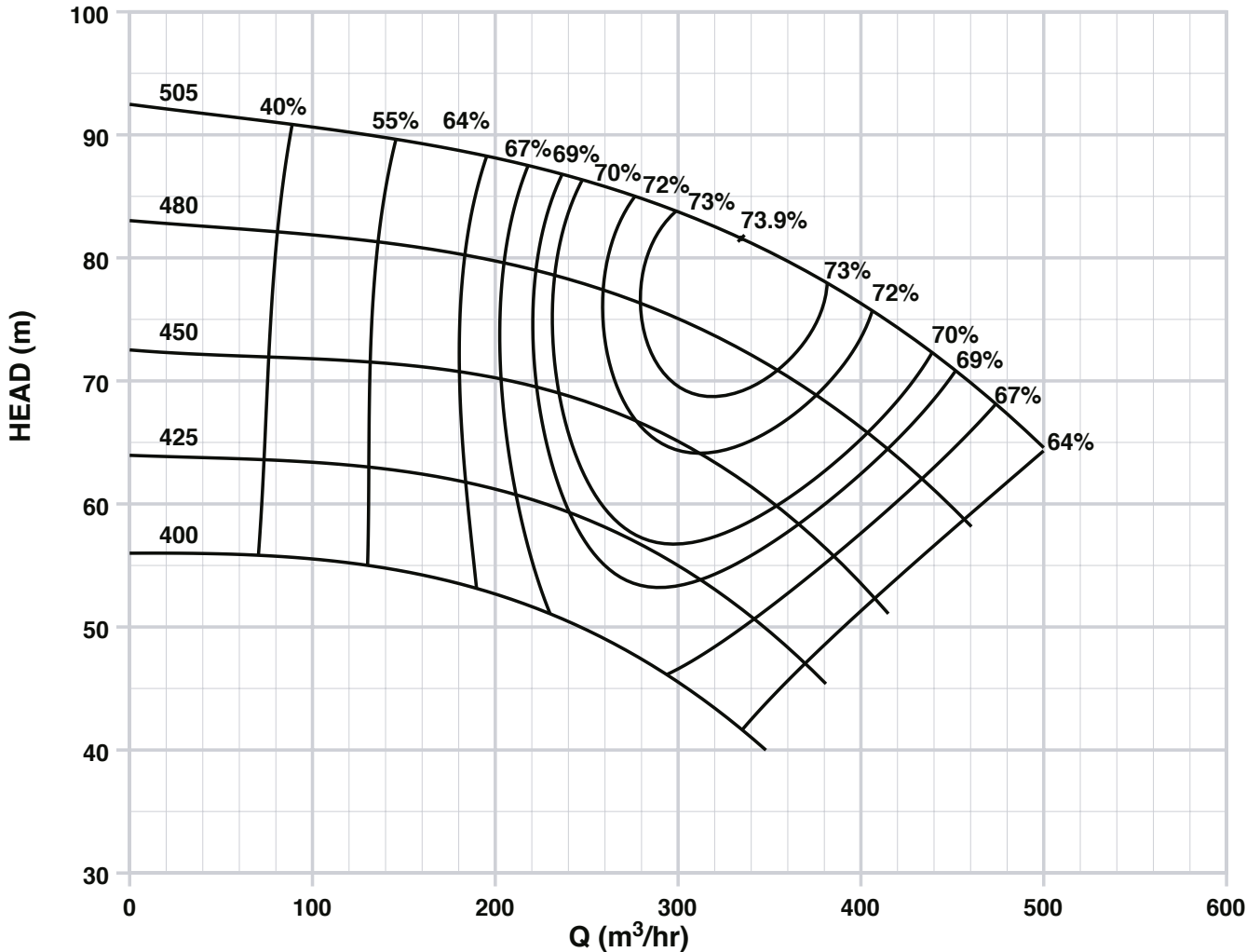

1450

CLT & CLB

MEDIUM-DUTY CENTRIFUGAL CHEMICAL PUMPS TO EN 733 (DIN 24256)



CHARACTERISTIC CURVE

Issue Date
OCTOBER 2005

Suction Diameter
200mm

Discharge Diameter
200mm

DIN 24 256
CLT 200-250

Based on water density 1000 kg/m³ and viscosity 1 cSt.
Head, capacity and efficiency according to ISO Standard 2548: 1973 Annex B

1450 rpm

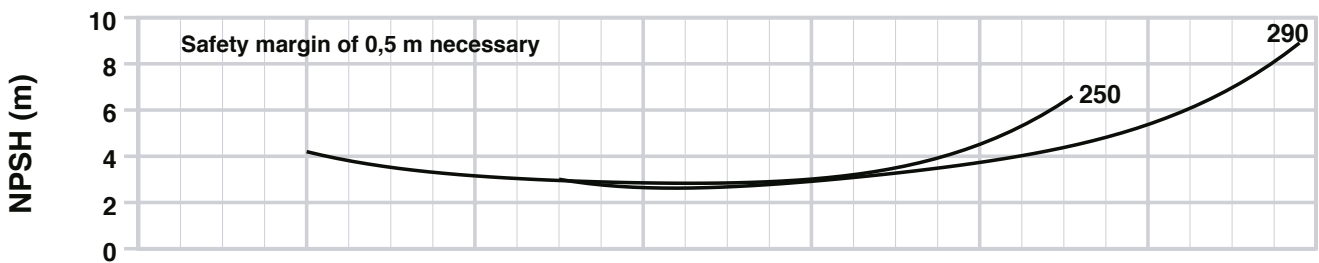
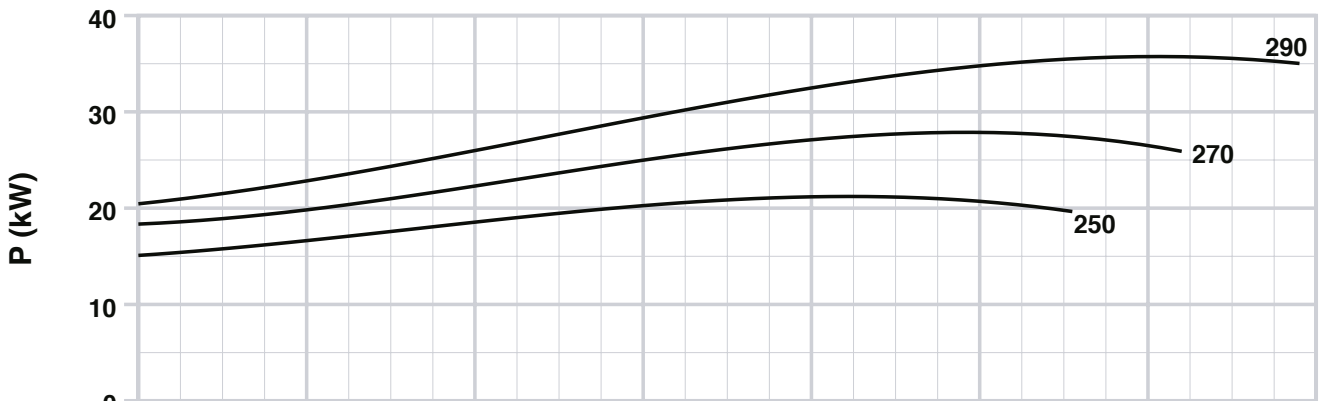
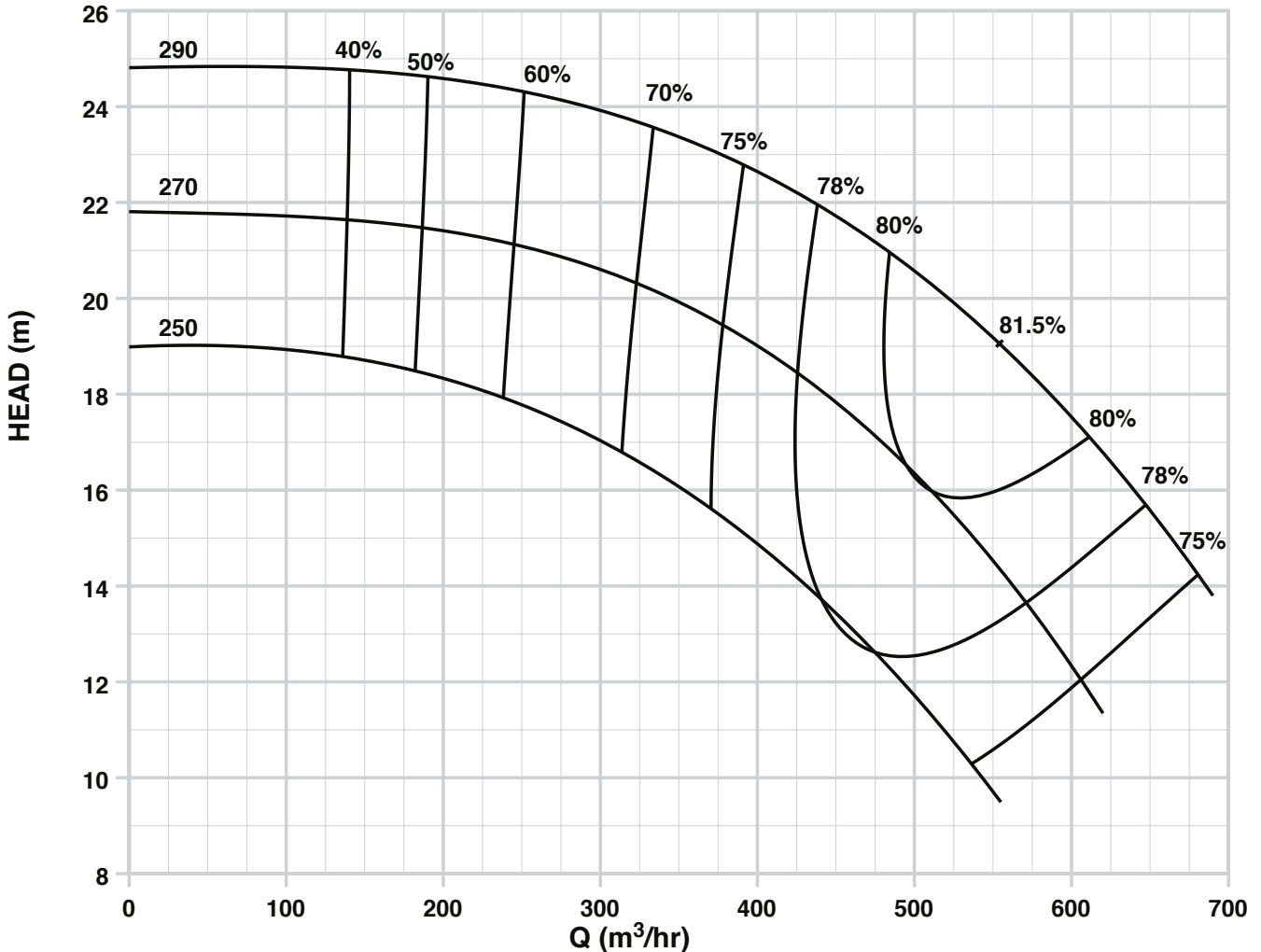

1450

CLT & CLB

MEDIUM-DUTY CENTRIFUGAL CHEMICAL PUMPS TO EN 733 (DIN 24256)



CHARACTERISTIC CURVE

DIN 24 256
CLT 200-315

Issue Date
OCTOBER 2005

Suction Diameter
250mm

Discharge Diameter
200mm

Based on water density 1000 kg/m³ and viscosity 1 cSt.
Head, capacity and efficiency according to ISO Standard 2548: 1973 Annex B

1450 rpm

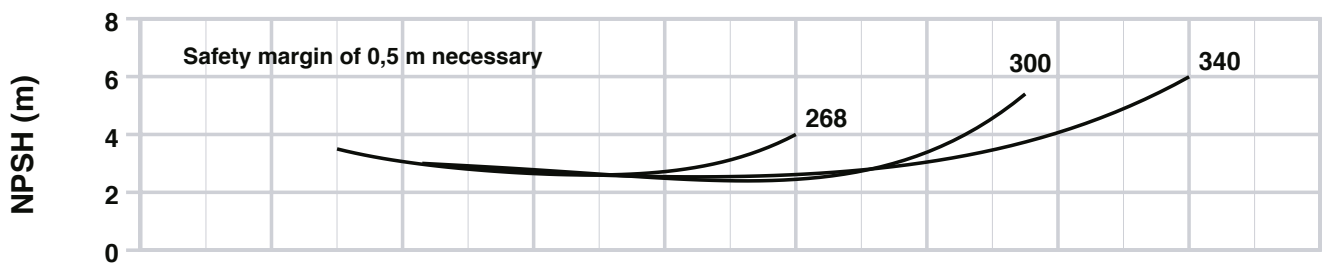
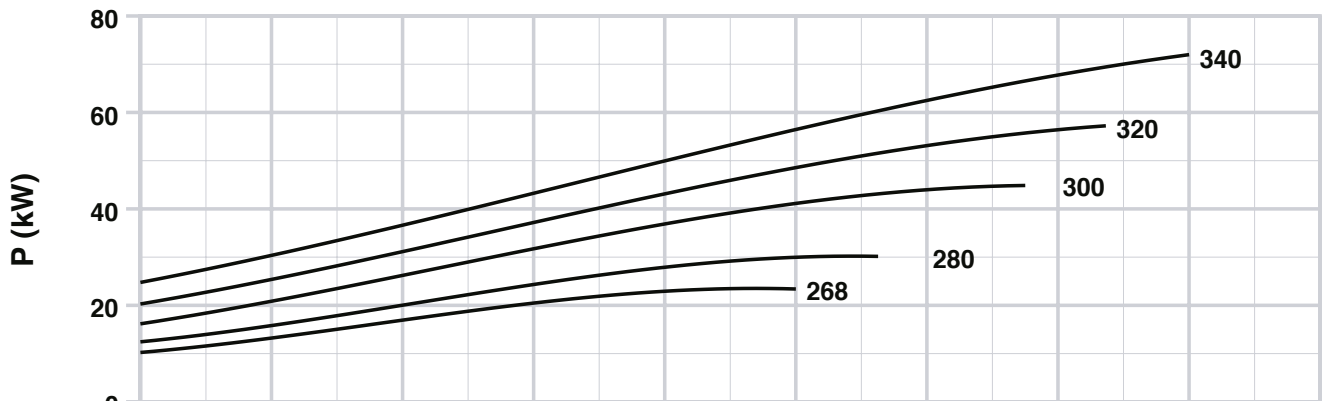
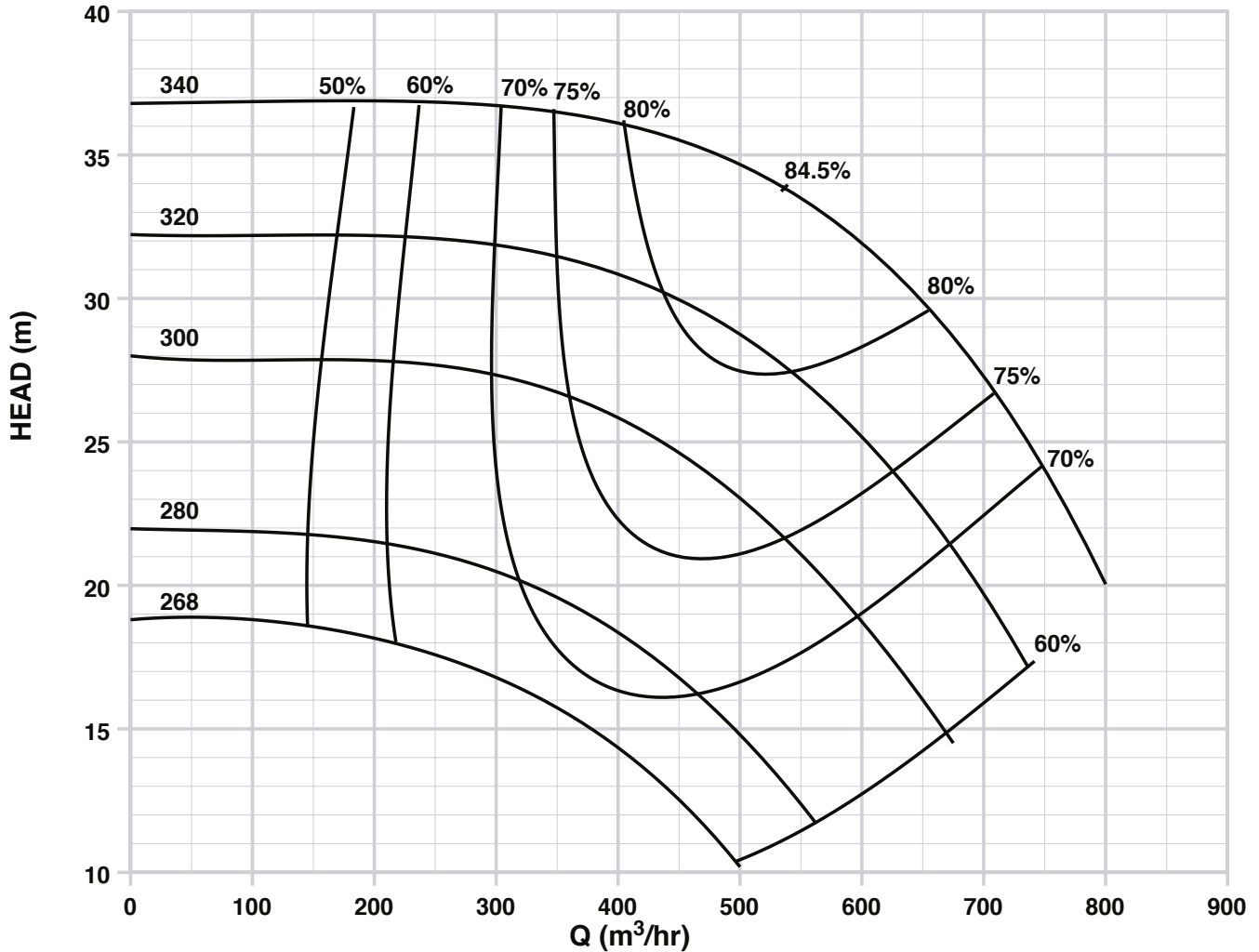

1450

CLT & CLB

MEDIUM-DUTY CENTRIFUGAL CHEMICAL PUMPS TO EN 733 (DIN 24256)



CHARACTERISTIC CURVE

Issue Date
OCTOBER 2005

Suction Diameter
250mm

Discharge Diameter
200mm

DIN 24 256
CLT 200-400

Based on water density 1000 kg/m³ and viscosity 1 cSt.
Head, capacity and efficiency according to ISO Standard 2548: 1973 Annex B

1450 rpm

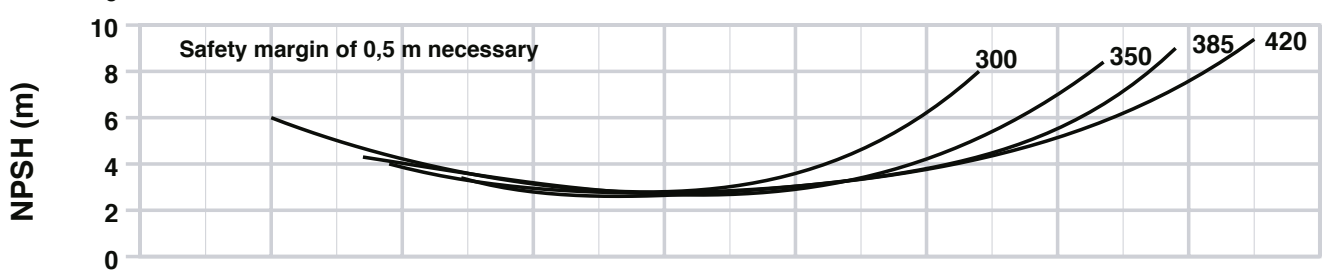
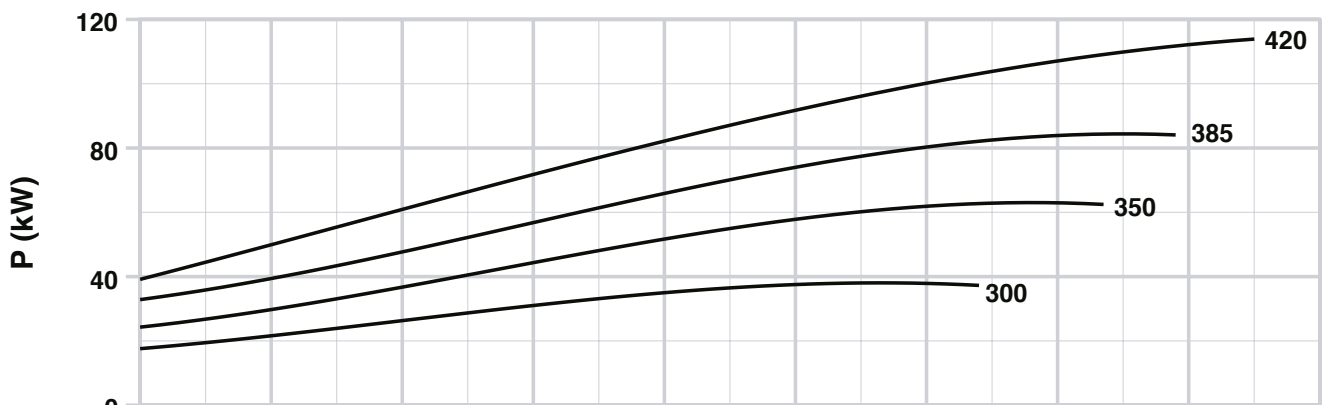
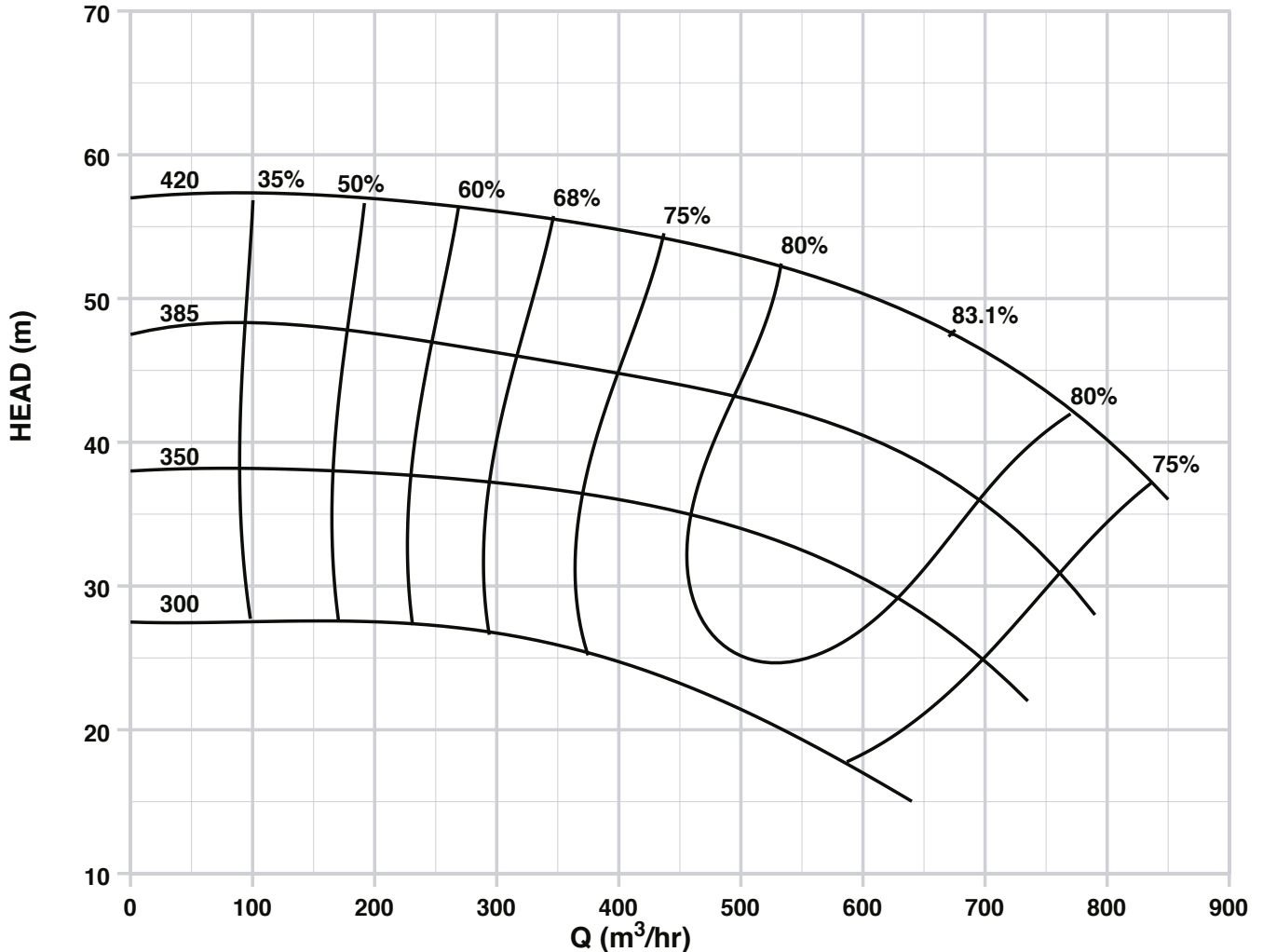

1450

CLT & CLB

MEDIUM-DUTY CENTRIFUGAL CHEMICAL PUMPS TO EN 733 (DIN 24256)



CHARACTERISTIC CURVE

Issue Date
OCTOBER 2005

Suction Diameter
250mm

Discharge Diameter
200mm

DIN 24 256
CLT 200-500

Based on water density 1000 kg/m³ and viscosity 1 cSt.
Head, capacity and efficiency according to ISO Standard 2548: 1973 Annex B

1450 rpm

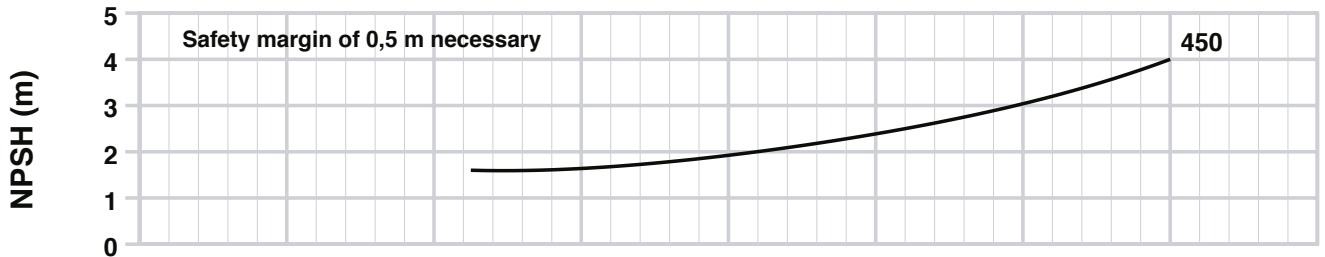
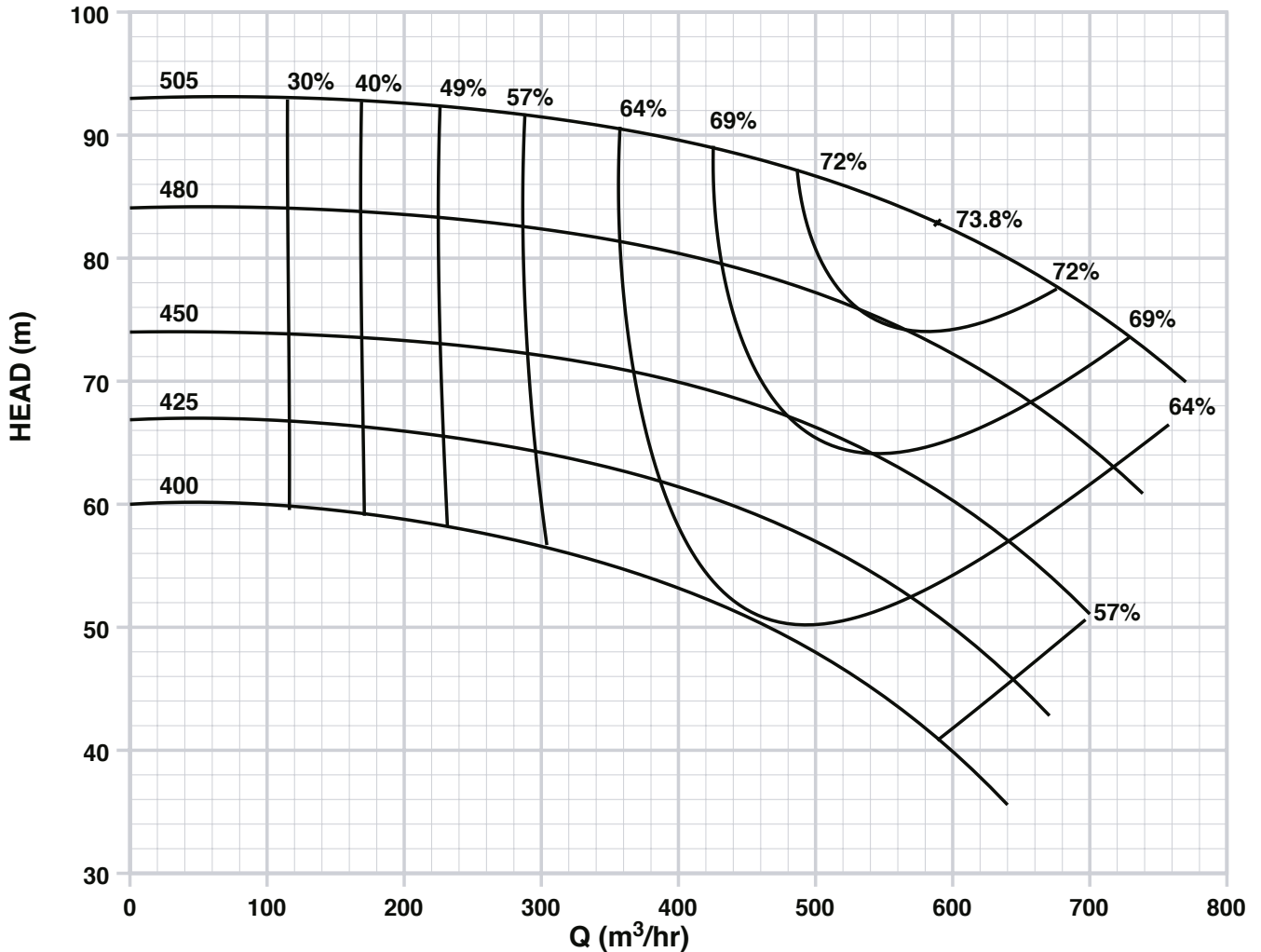

1450

CLT & CLB

MEDIUM-DUTY CENTRIFUGAL CHEMICAL PUMPS TO EN 733 (DIN 24256)



CHARACTERISTIC CURVE

Issue Date
OCTOBER 2005

Suction Diameter
300mm

Discharge Diameter
250mm

DIN 24 256
CLT 250-315

Based on water density 1000 kg/m³ and viscosity 1 cSt.
Head, capacity and efficiency according to ISO Standard 2548: 1973 Annex B

1450 rpm

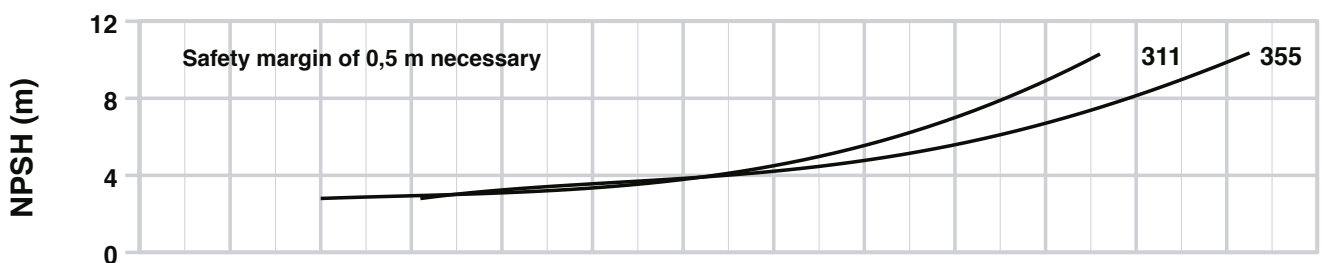
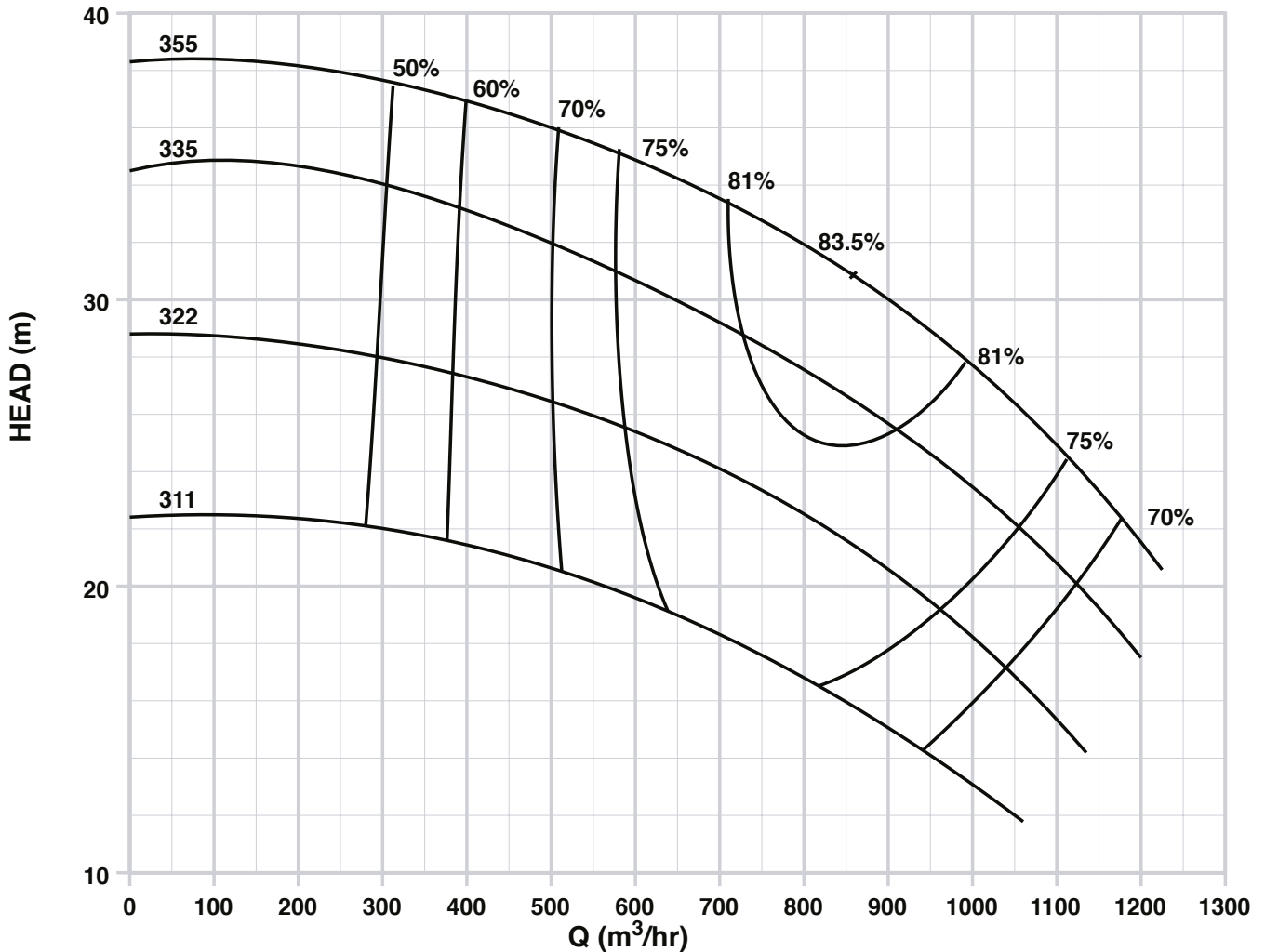

1450

CLT & CLB

MEDIUM-DUTY CENTRIFUGAL CHEMICAL PUMPS TO EN 733 (DIN 24256)



CHARACTERISTIC CURVE

DIN 24 256
CLT 250-400

Issue Date
OCTOBER 2005

Suction Diameter
300mm

Discharge Diameter
250mm

Based on water density 1000 kg/m³ and viscosity 1 cSt.
Head, capacity and efficiency according to ISO Standard 2548: 1973 Annex B

1450 rpm

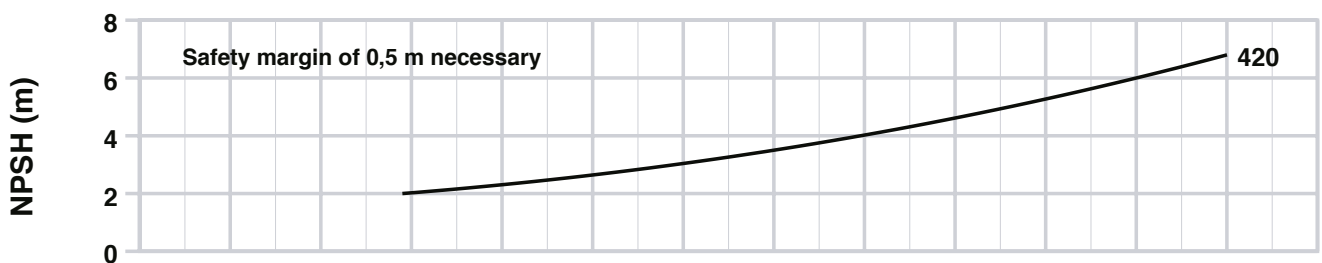
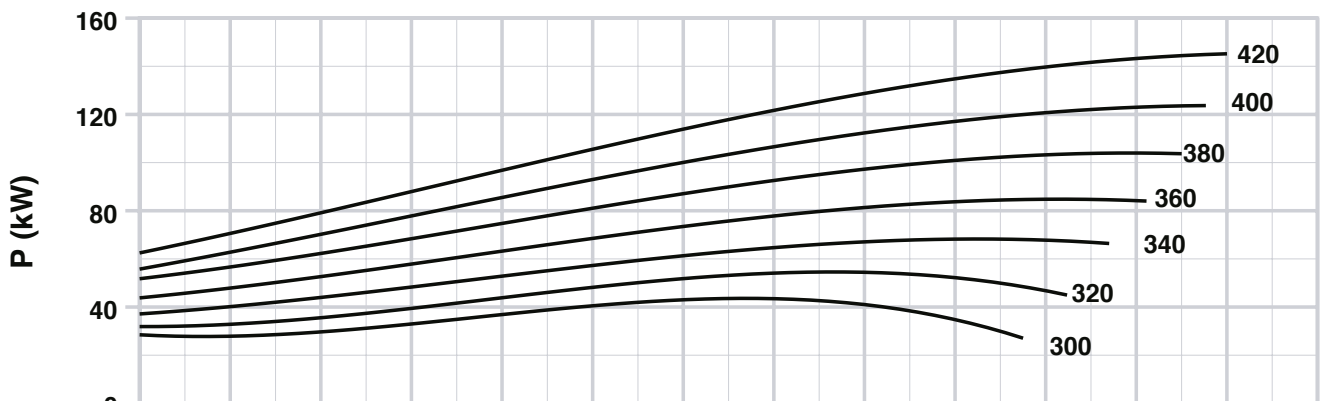
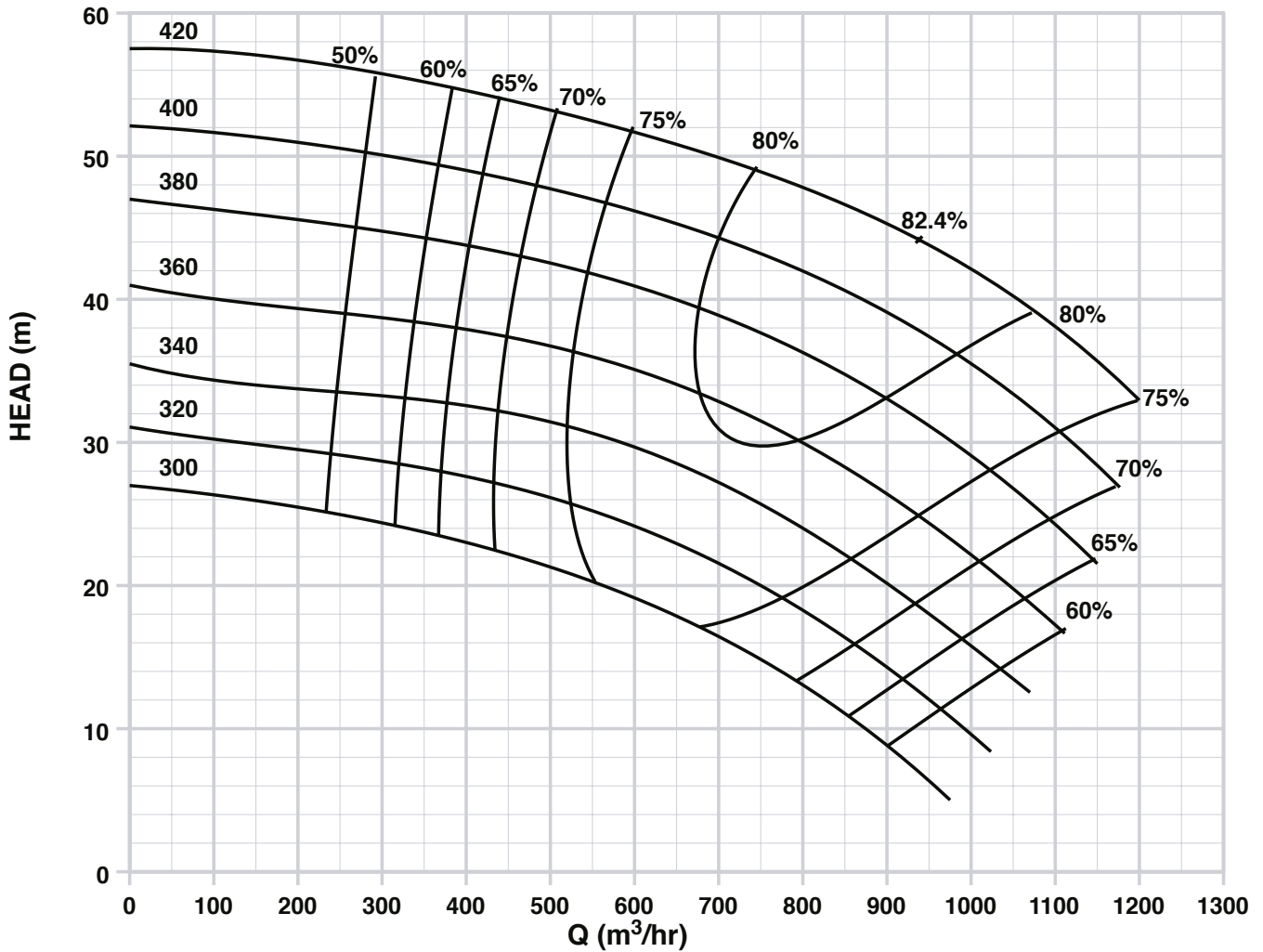

1450

CLT & CLB

MEDIUM-DUTY CENTRIFUGAL CHEMICAL PUMPS TO EN 733 (DIN 24256)

	CHARACTERISTIC CURVE		DIN 24 256	
	Issue Date OCTOBER 2005	Suction Diameter 40mm	Discharge Diameter 25mm	CLT 25- 160
	Based on water density 1000 kg/m ³ and viscosity 1 cSt. Head, capacity and efficiency according to ISO Standard 2548: 1973 Annex B			2900 rpm

2900

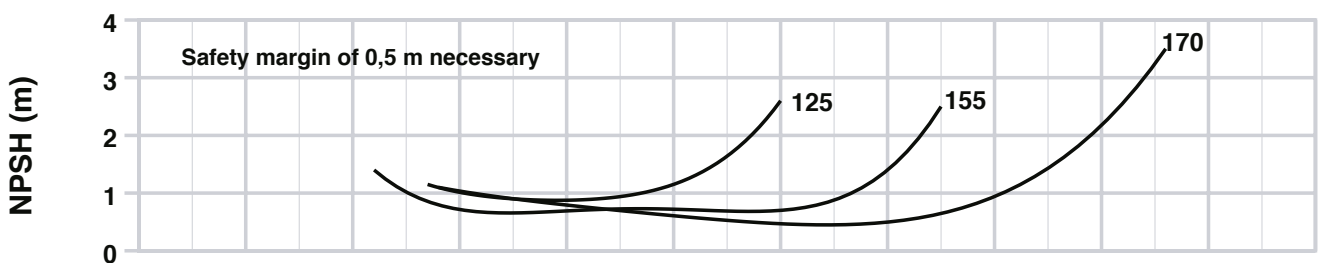
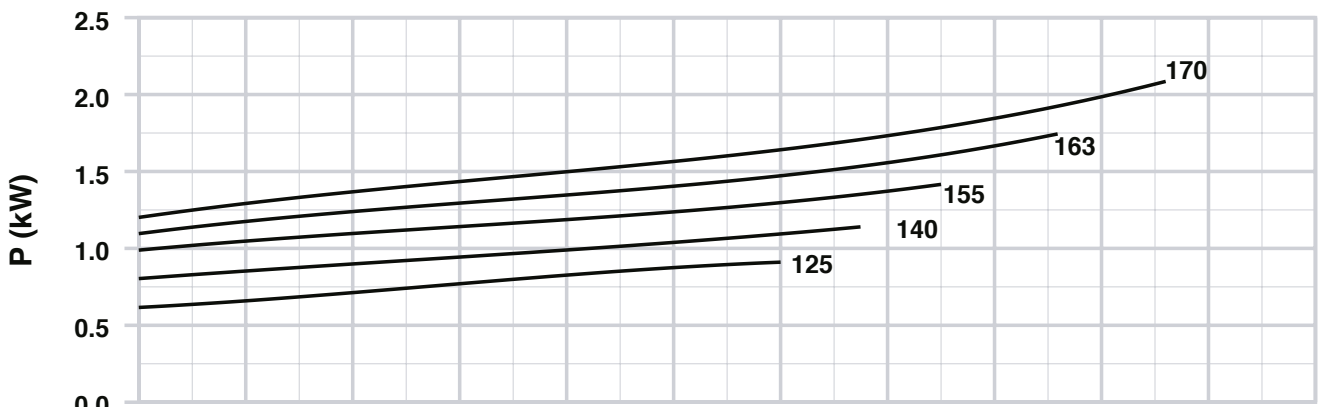
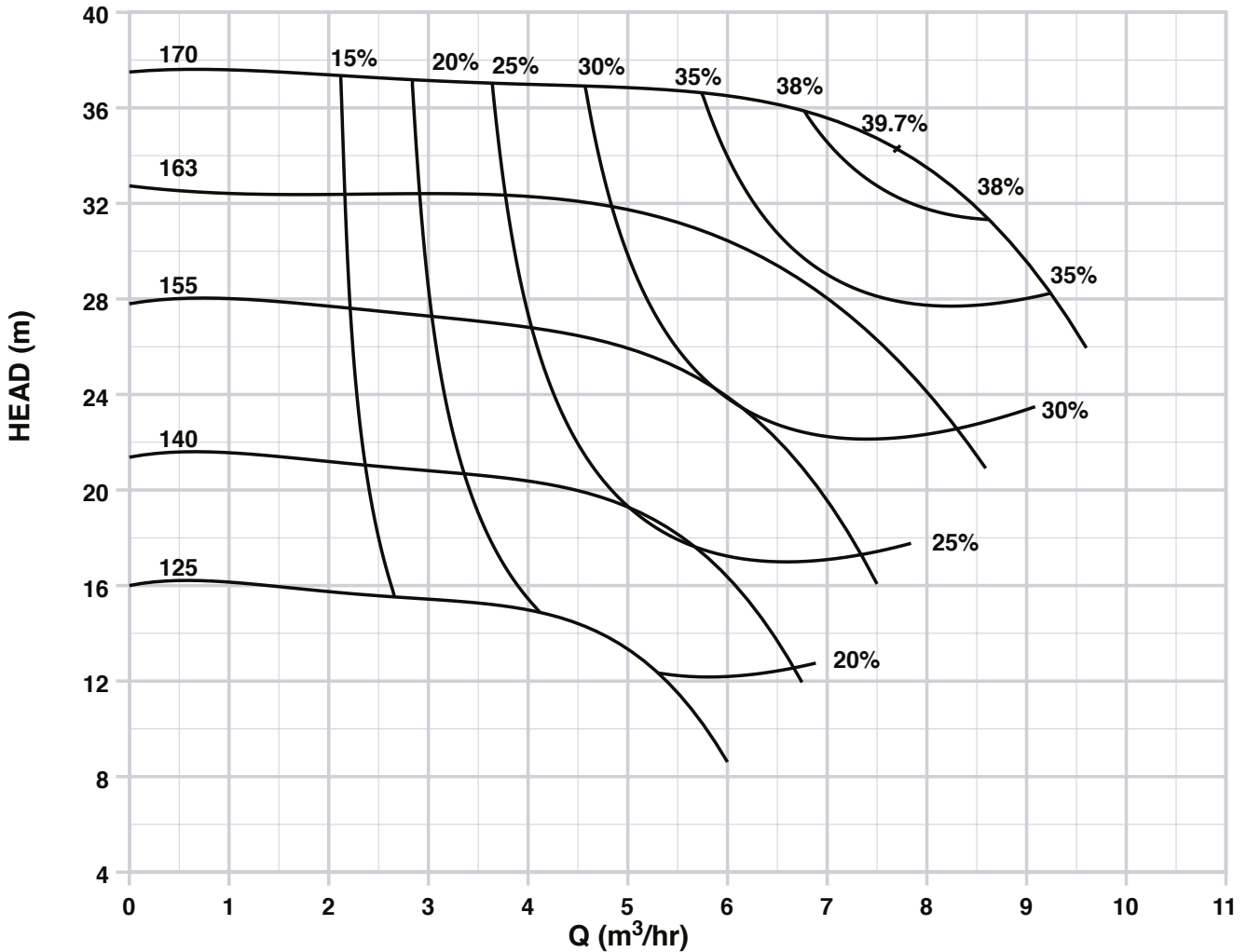

CLT & CLB

MEDIUM-DUTY CENTRIFUGAL CHEMICAL PUMPS TO EN 733 (DIN 24256)



CHARACTERISTIC CURVE

Issue Date
OCTOBER 2005

Suction Diameter
40mm

Discharge Diameter
25mm

DIN 24 256
CLT 25-200

Based on water density 1000 kg/m³ and viscosity 1 cSt.
Head, capacity and efficiency according to ISO Standard 2548: 1973 Annex B

2900 rpm

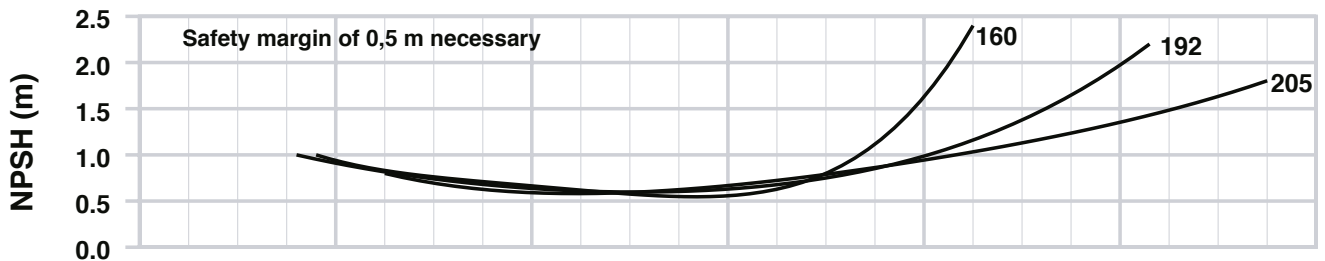
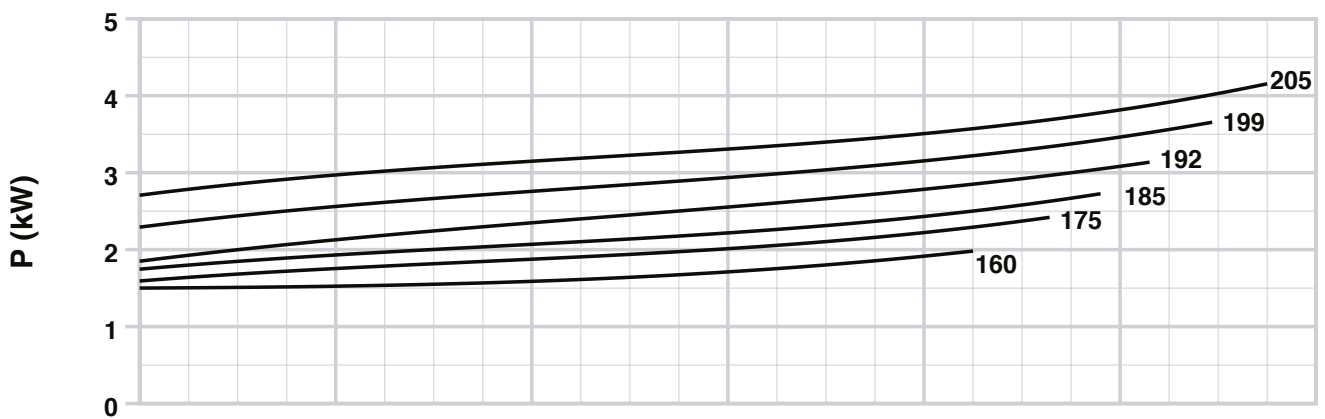
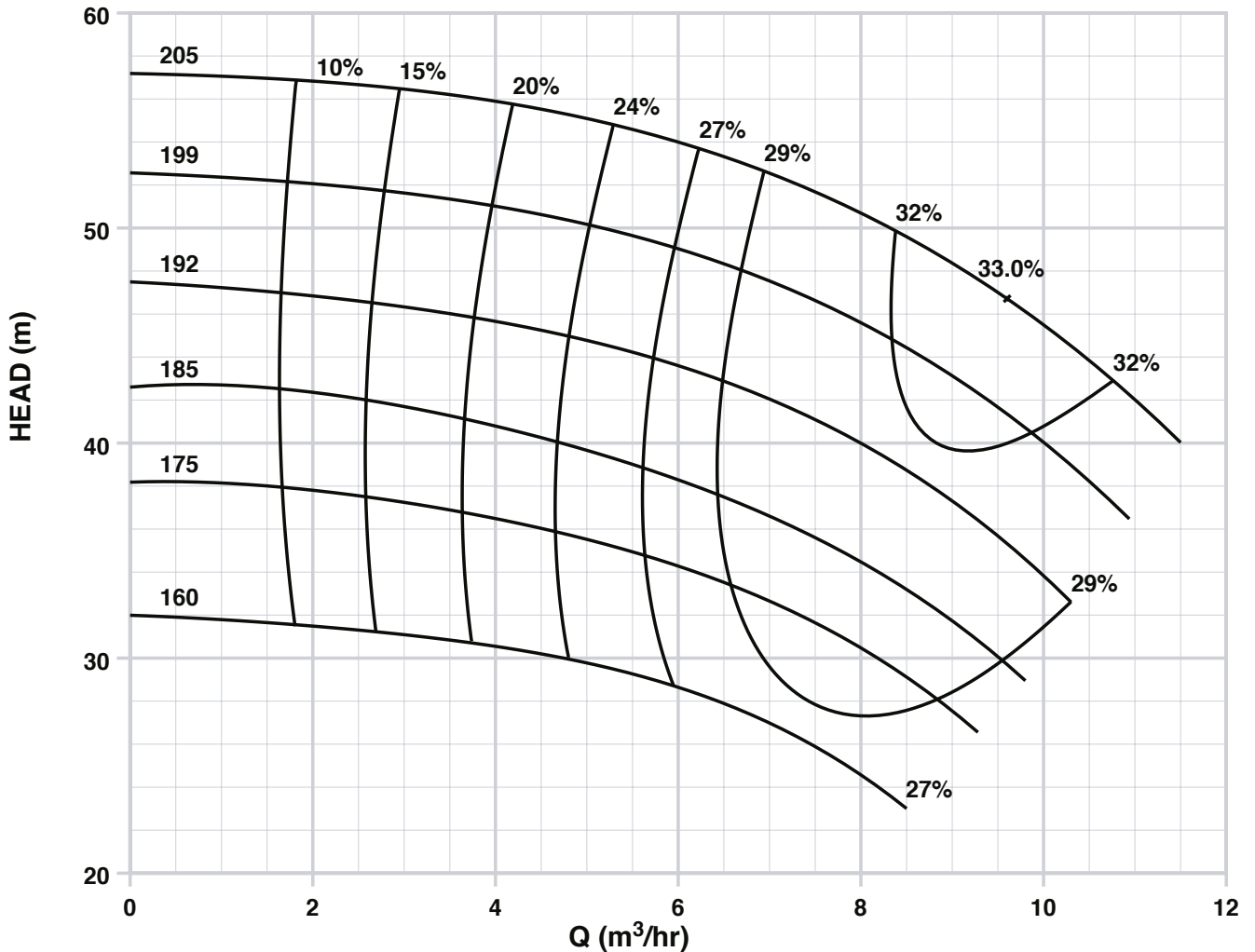

2900

CLT & CLB

MEDIUM-DUTY CENTRIFUGAL CHEMICAL PUMPS TO EN 733 (DIN 24256)



CHARACTERISTIC CURVE

Issue Date
OCTOBER 2005

Suction Diameter
50mm

Discharge Diameter
32mm

DIN 24 256
CLT 32-160

Based on water density 1000 kg/m³ and viscosity 1 cSt.
Head, capacity and efficiency according to ISO Standard 2548: 1973 Annex B

2900 rpm

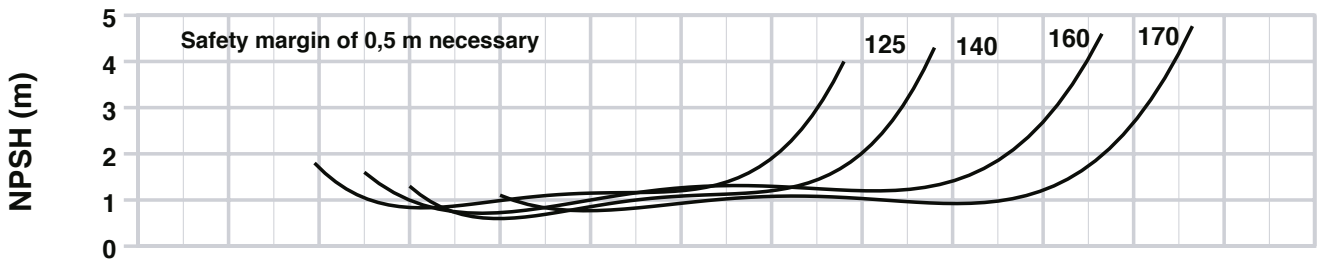
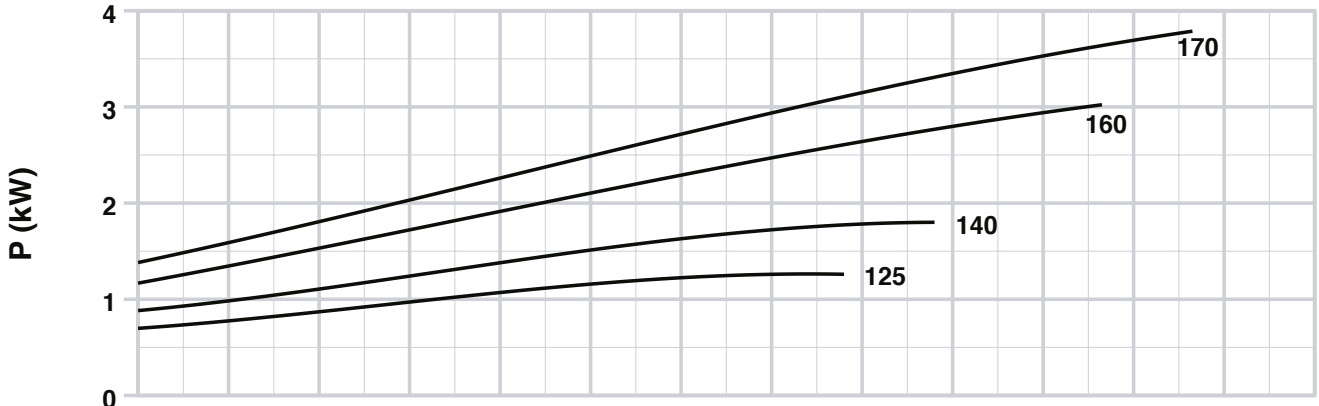
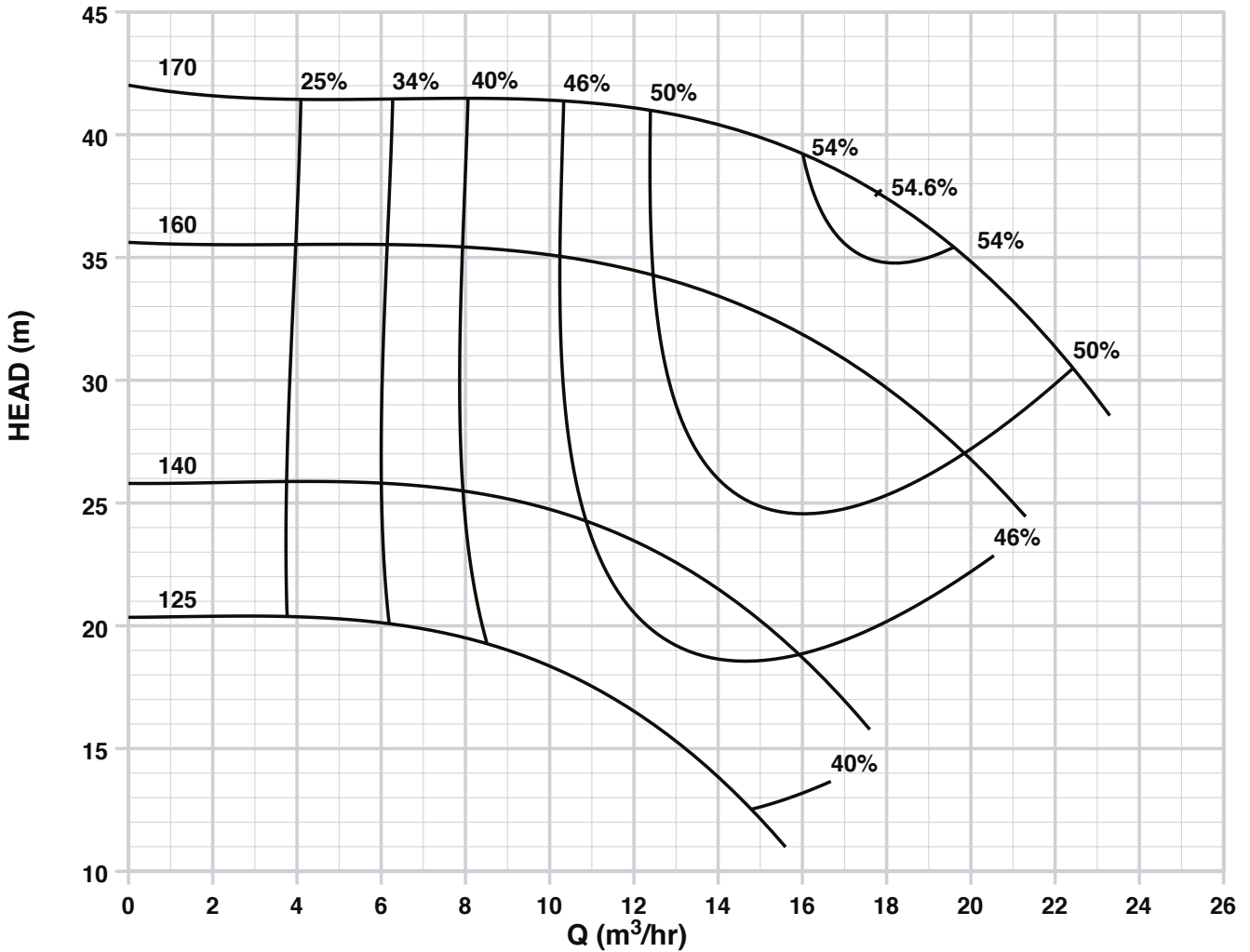

2900

CLT & CLB

MEDIUM-DUTY CENTRIFUGAL CHEMICAL PUMPS TO EN 733 (DIN 24256)



CHARACTERISTIC CURVE

Issue Date
OCTOBER 2005

Suction Diameter
50mm

Discharge Diameter
32mm

DIN 24 256
CLT 32-200

Based on water density 1000 kg/m³ and viscosity 1 cSt.
Head, capacity and efficiency according to ISO Standard 2548: 1973 Annex B

2900 rpm

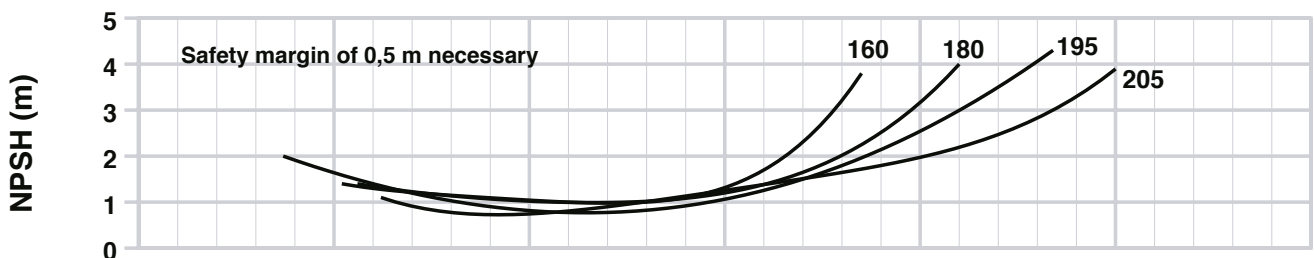
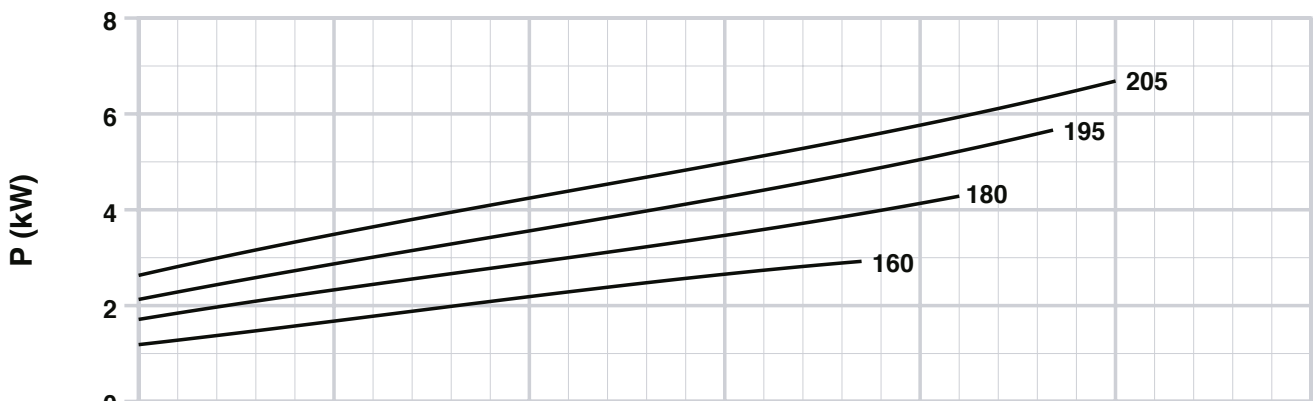
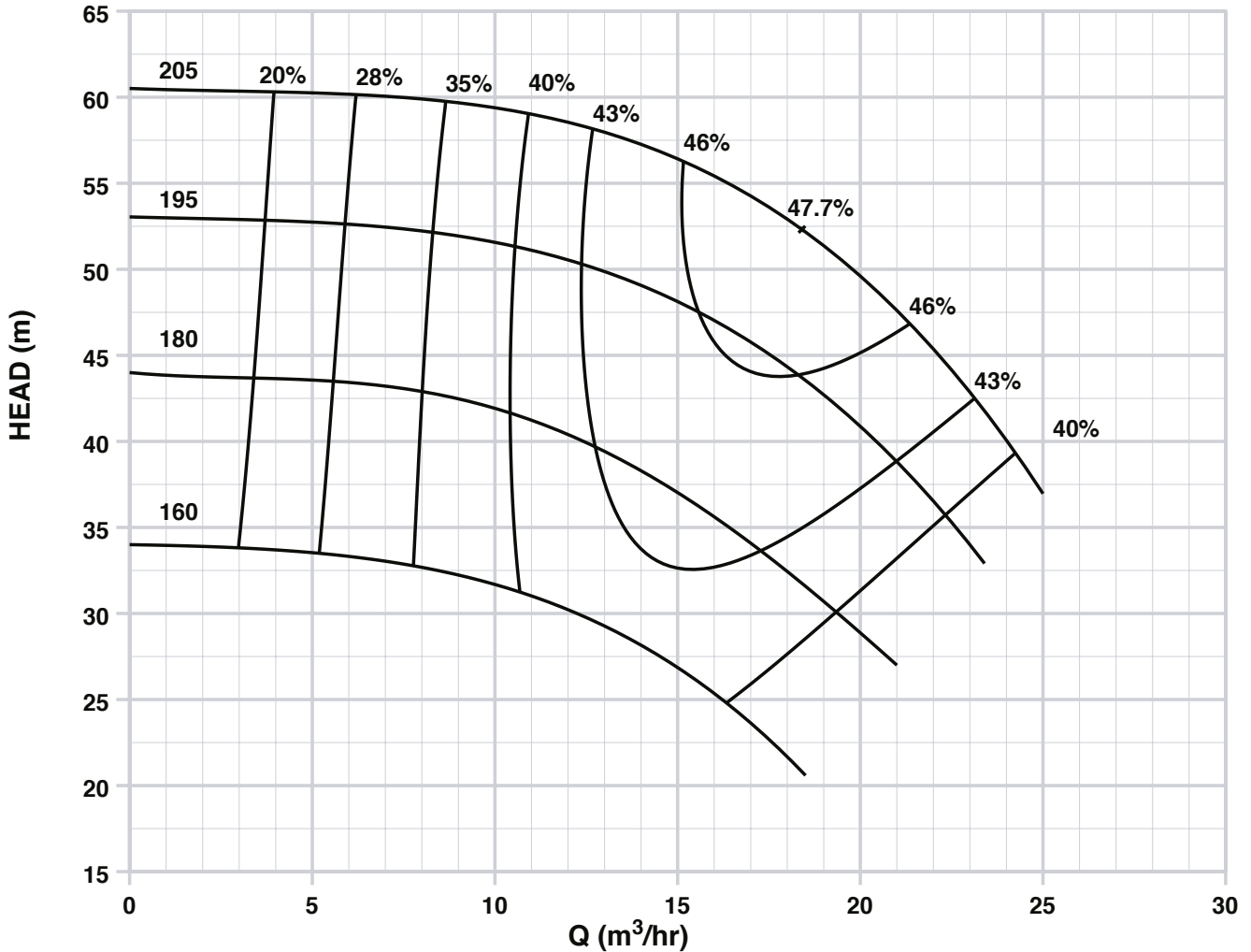

2900

CLT & CLB

MEDIUM-DUTY CENTRIFUGAL CHEMICAL PUMPS TO EN 733 (DIN 24256)



CHARACTERISTIC CURVE

Issue Date
OCTOBER 2005

Suction Diameter
50mm

Discharge Diameter
32mm

DIN 24 256
CLT 32- 250

Based on water density 1000 kg/m³ and viscosity 1 cSt.
Head, capacity and efficiency according to ISO Standard 2548: 1973 Annex B

2900 rpm

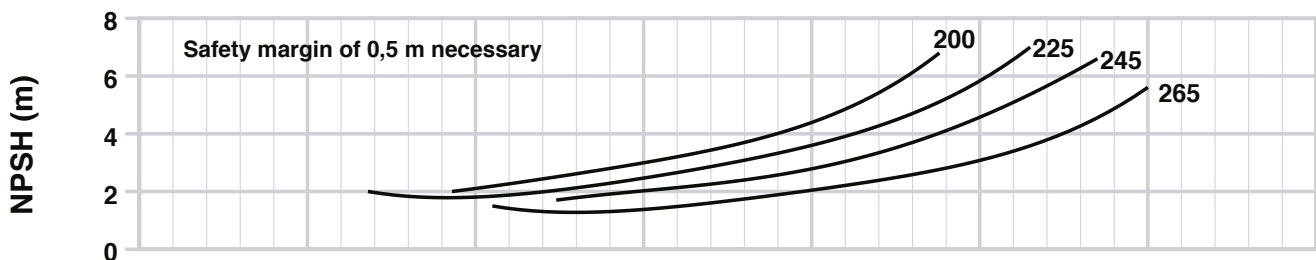
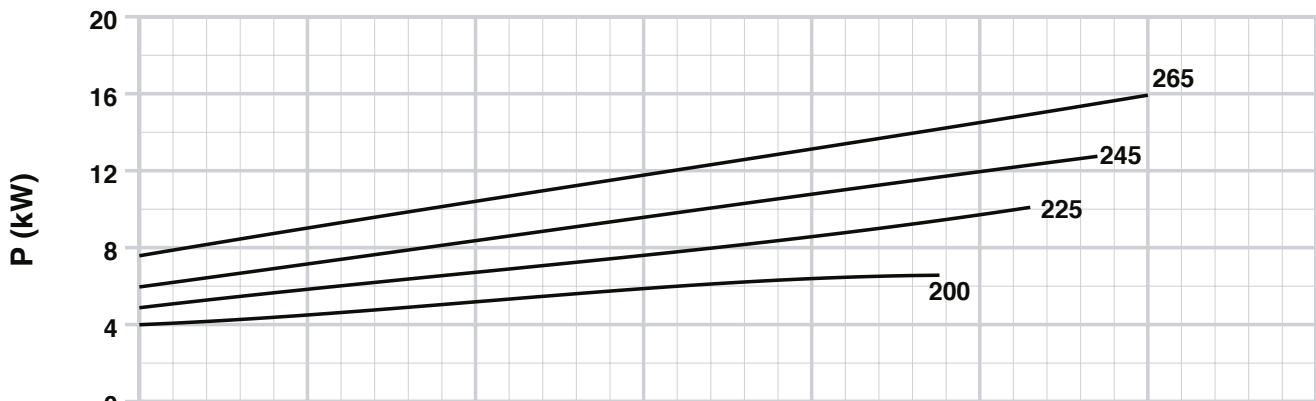
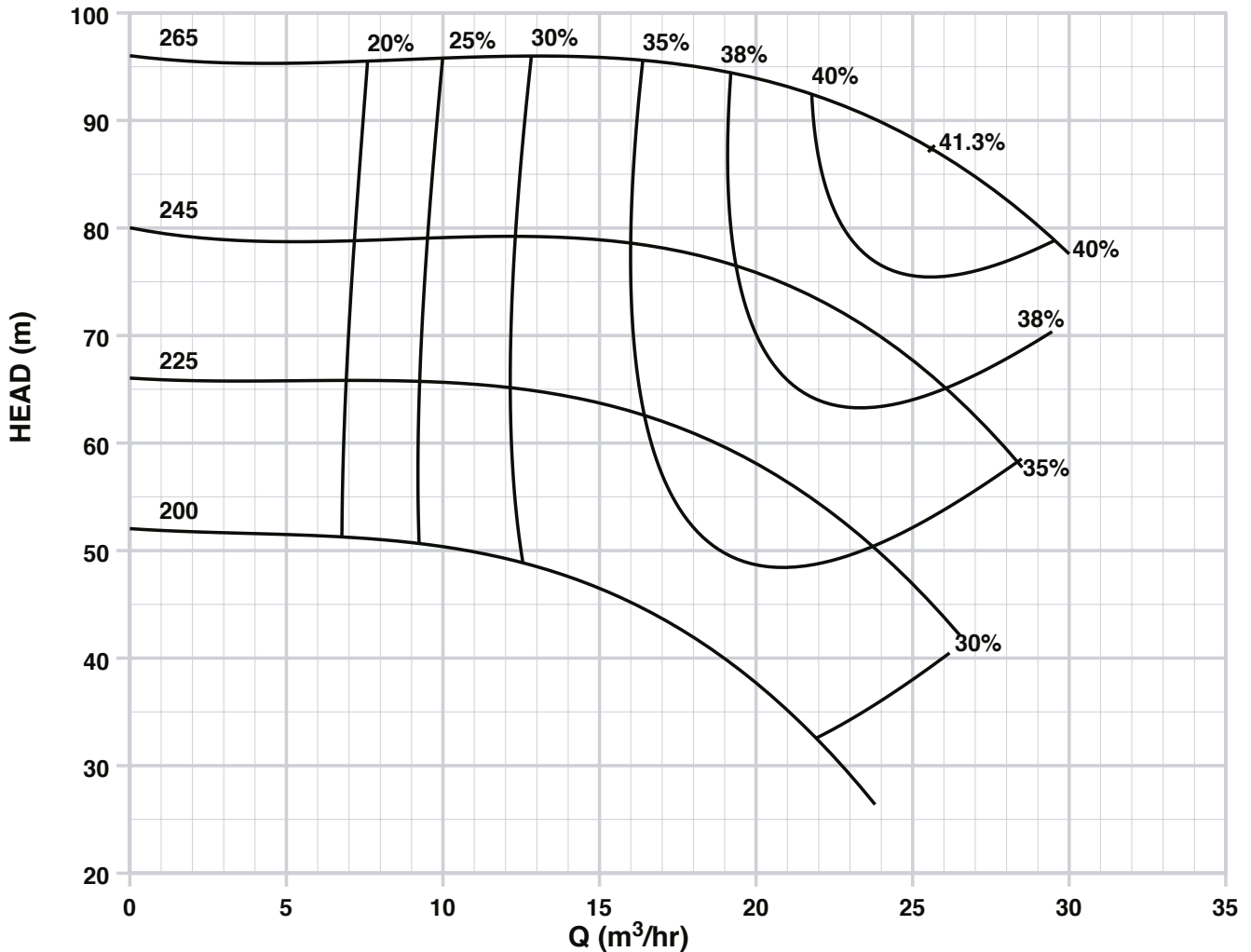

2900

CLT & CLB

MEDIUM-DUTY CENTRIFUGAL CHEMICAL PUMPS TO EN 733 (DIN 24256)



CHARACTERISTIC CURVE

Issue Date
OCTOBER 2005

Suction Diameter
65mm

Discharge Diameter
40mm

DIN 24 256
CLT 40-160

Based on water density 1000 kg/m³ and viscosity 1 cSt.
Head, capacity and efficiency according to ISO Standard 2548: 1973 Annex B

2900 rpm

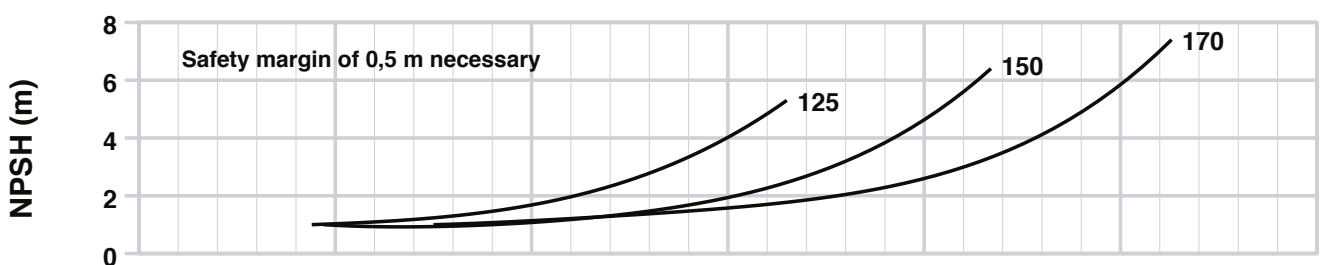
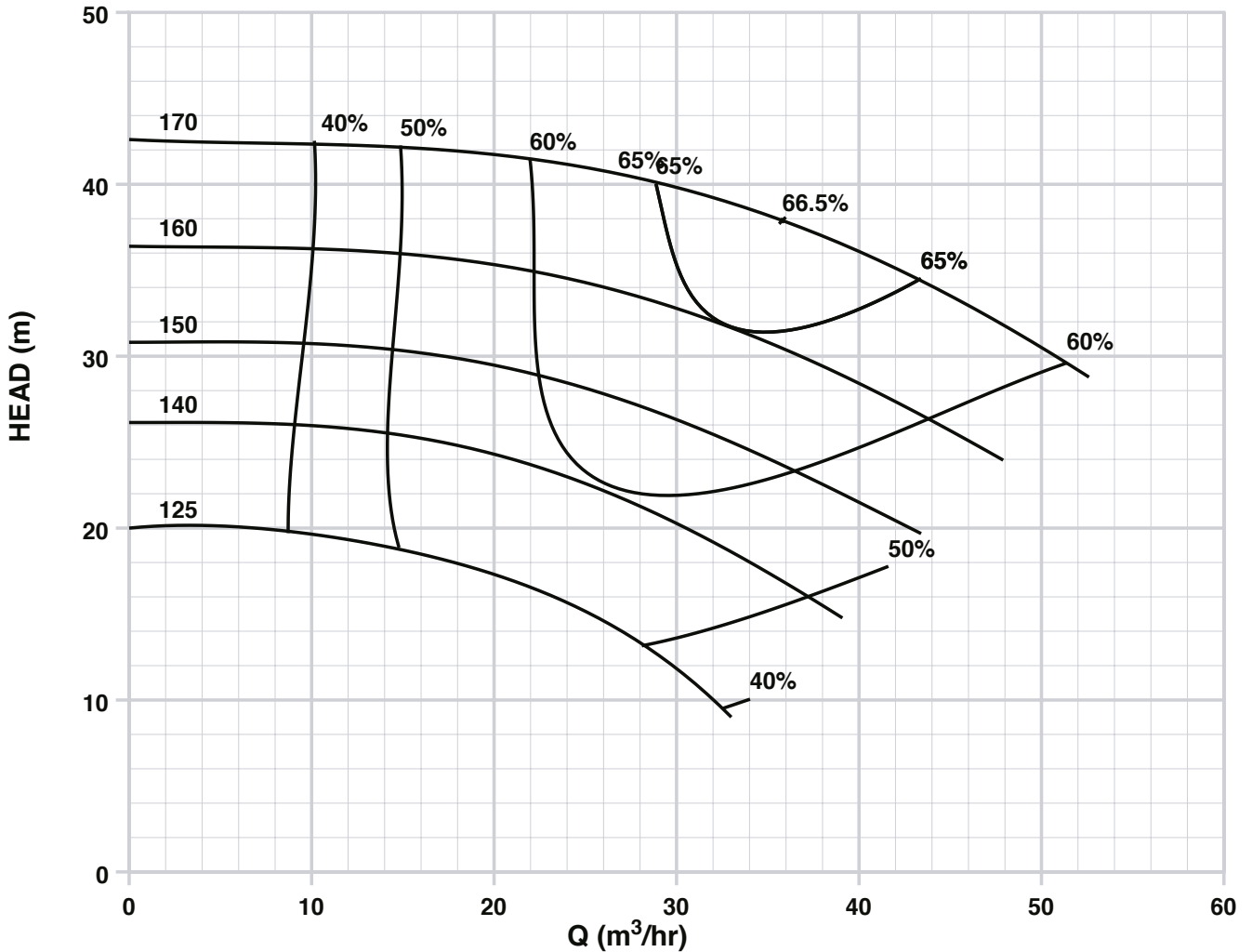

2900

CLT & CLB

MEDIUM-DUTY CENTRIFUGAL CHEMICAL PUMPS TO EN 733 (DIN 24256)



CHARACTERISTIC CURVE

Issue Date
OCTOBER 2005

Suction Diameter
65mm

Discharge Diameter
40mm

DIN 24 256
CLT 40-200

Based on water density 1000 kg/m³ and viscosity 1 cSt.
Head, capacity and efficiency according to ISO Standard 2548: 1973 Annex B

2900 rpm

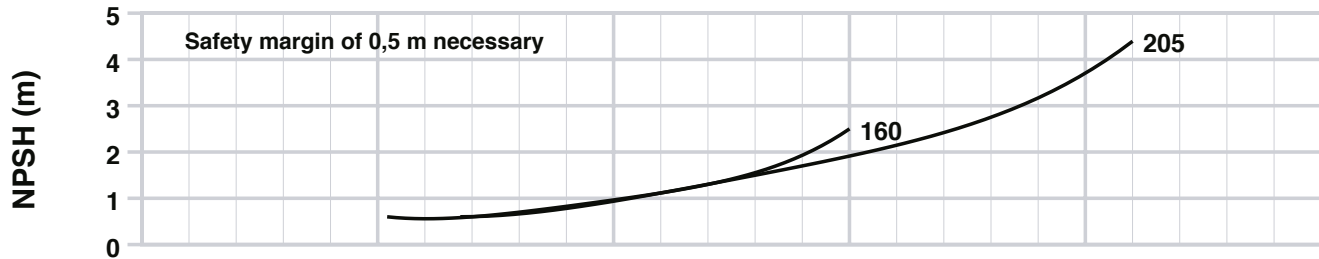
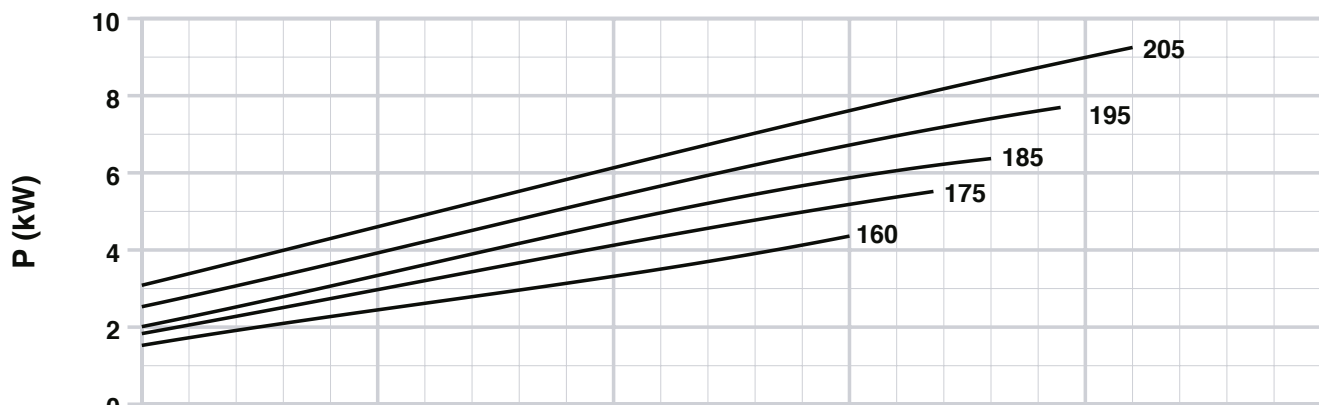
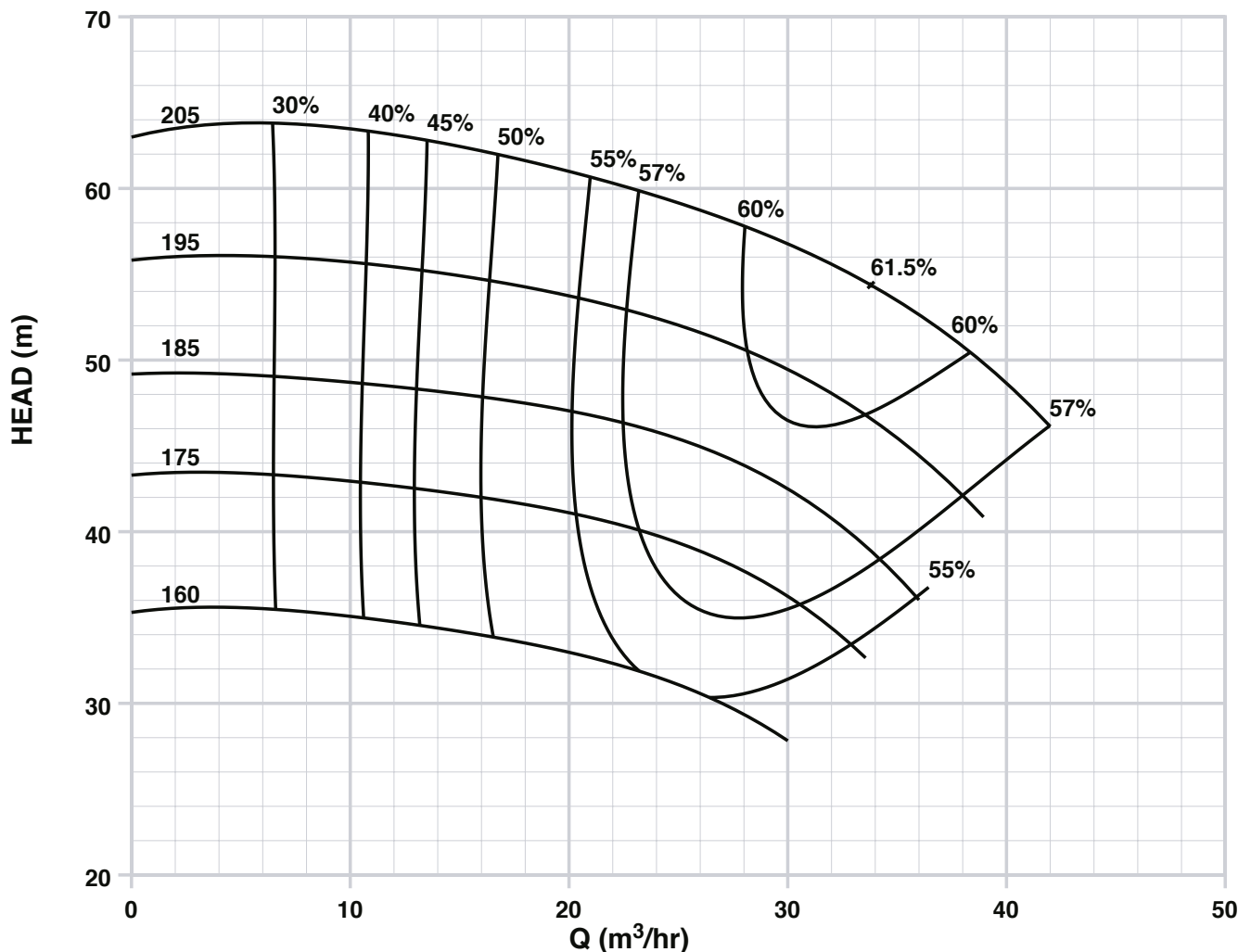

2900

CLT & CLB

MEDIUM-DUTY CENTRIFUGAL CHEMICAL PUMPS TO EN 733 (DIN 24256)



CHARACTERISTIC CURVE

Issue Date
OCTOBER 2005

Suction Diameter
65mm

Discharge Diameter
40mm

DIN 24 256
CLT 40-250

Based on water density 1000 kg/m³ and viscosity 1 cSt.
Head, capacity and efficiency according to ISO Standard 2548: 1973 Annex B

2900 rpm

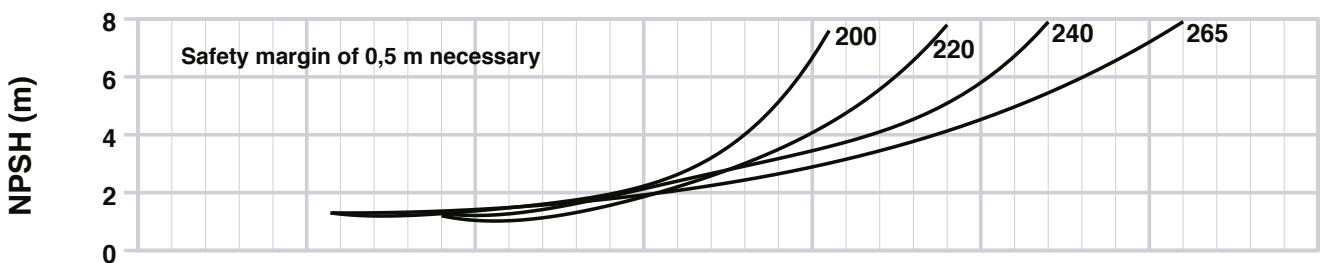
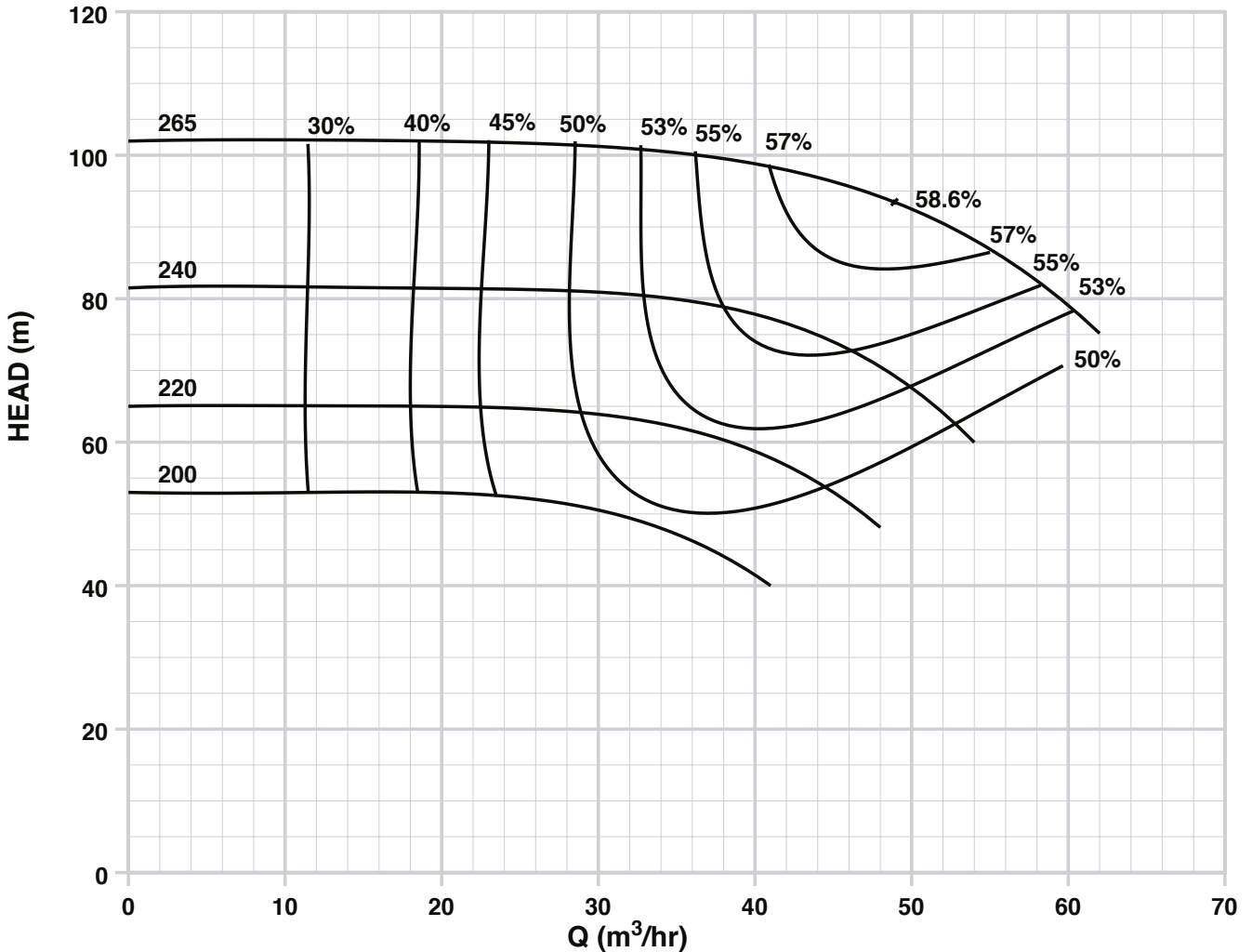

2900

CLT & CLB

MEDIUM-DUTY CENTRIFUGAL CHEMICAL PUMPS TO EN 733 (DIN 24256)



CHARACTERISTIC CURVE

Issue Date
OCTOBER 2005

Suction Diameter
65mm

Discharge Diameter
40mm

DIN 24 256
CLT 40-315

Based on water density 1000 kg/m³ and viscosity 1 cSt.
Head, capacity and efficiency according to ISO Standard 2548: 1973 Annex B

2900 rpm

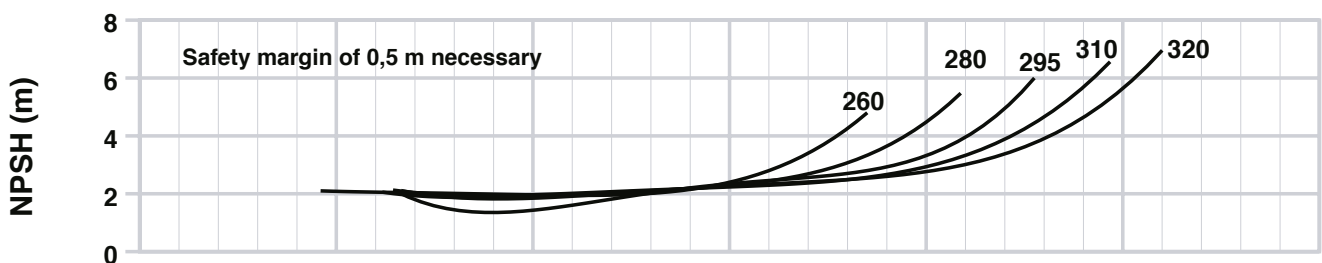
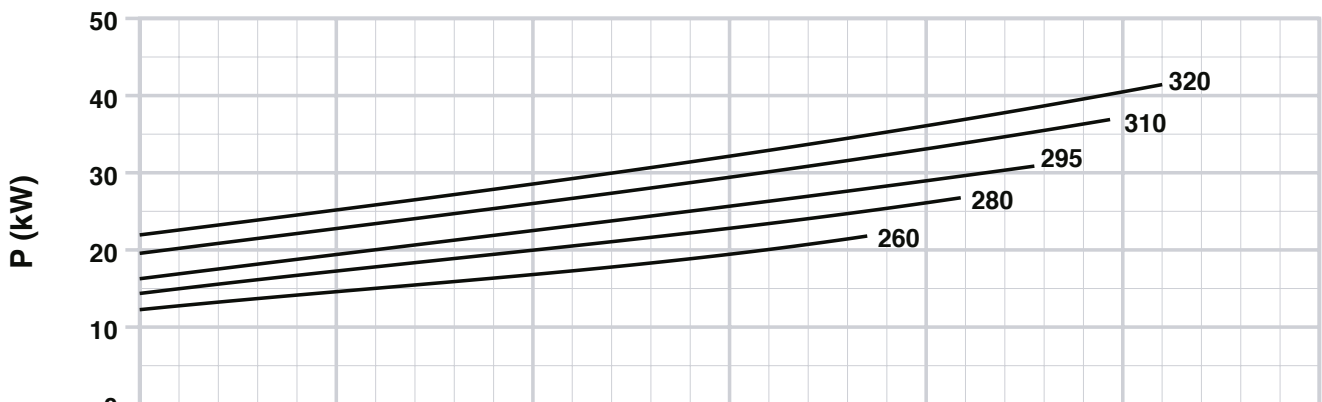
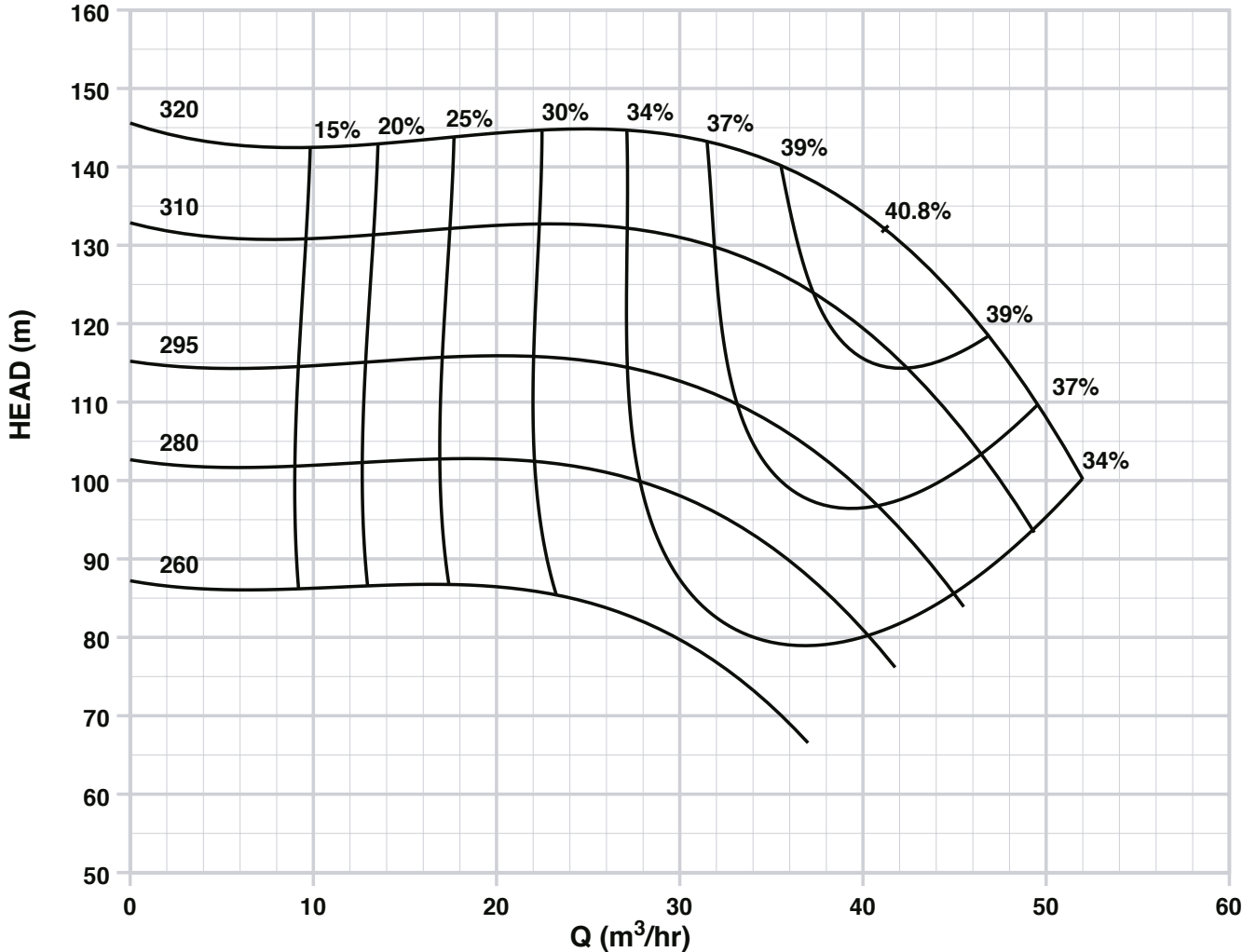

2900

CLT & CLB

MEDIUM-DUTY CENTRIFUGAL CHEMICAL PUMPS TO EN 733 (DIN 24256)



CHARACTERISTIC CURVE

Issue Date
OCTOBER 2005

Suction Diameter
80mm

Discharge Diameter
50mm

DIN 24 256
CLT 50-160

Based on water density 1000 kg/m³ and viscosity 1 cSt.
Head, capacity and efficiency according to ISO Standard 2548: 1973 Annex B

2900 rpm

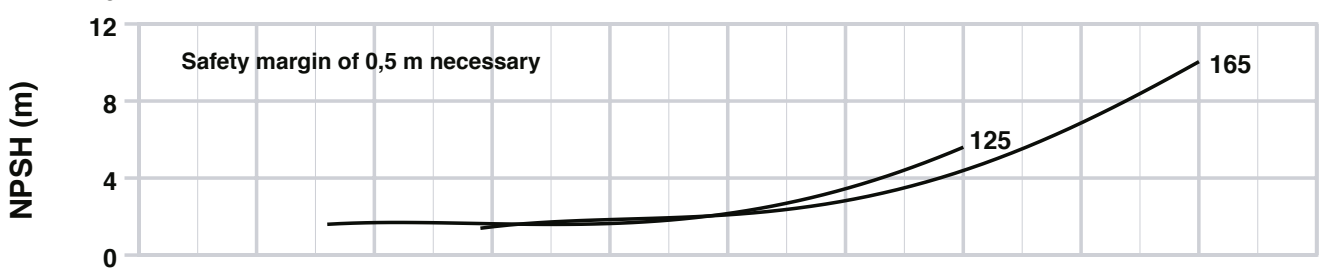
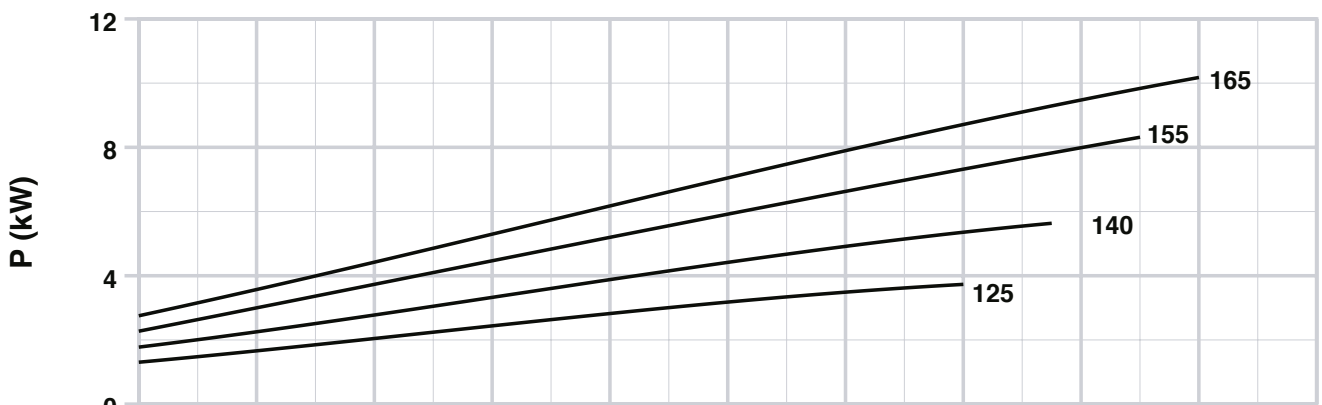
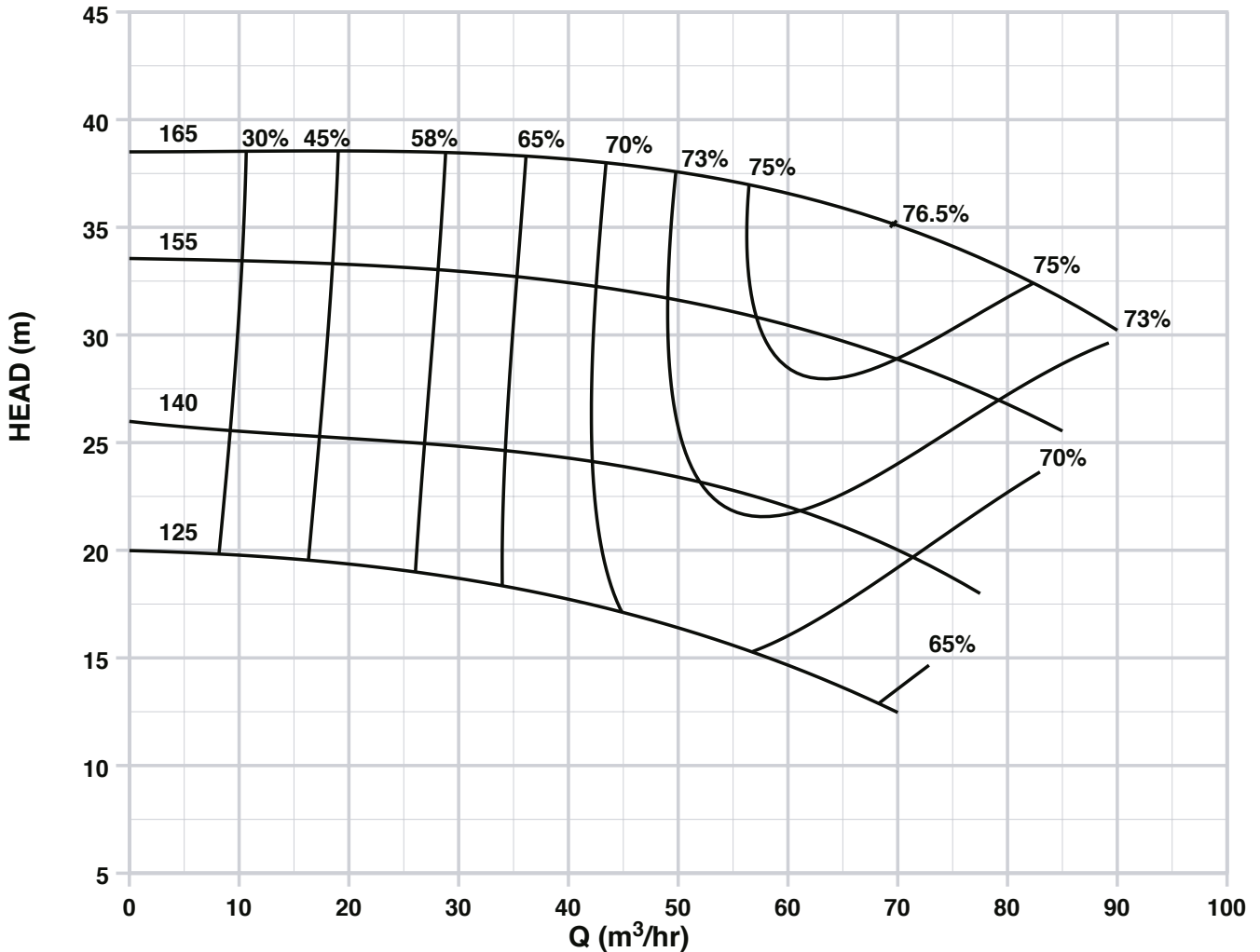

2900

CLT & CLB

MEDIUM-DUTY CENTRIFUGAL CHEMICAL PUMPS TO EN 733 (DIN 24256)



CHARACTERISTIC CURVE

Issue Date
OCTOBER 2005

Suction Diameter
80mm

Discharge Diameter
50mm

DIN 24 256
CLT 50-200

Based on water density 1000 kg/m³ and viscosity 1 cSt.
Head, capacity and efficiency according to ISO Standard 2548: 1973 Annex B

2900 rpm

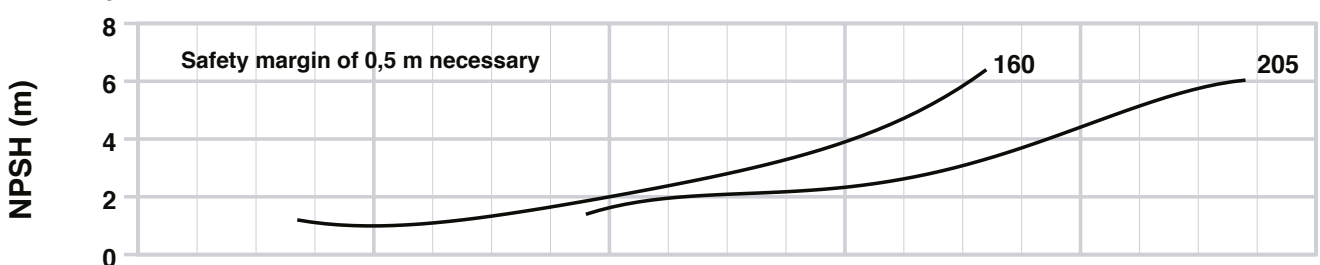
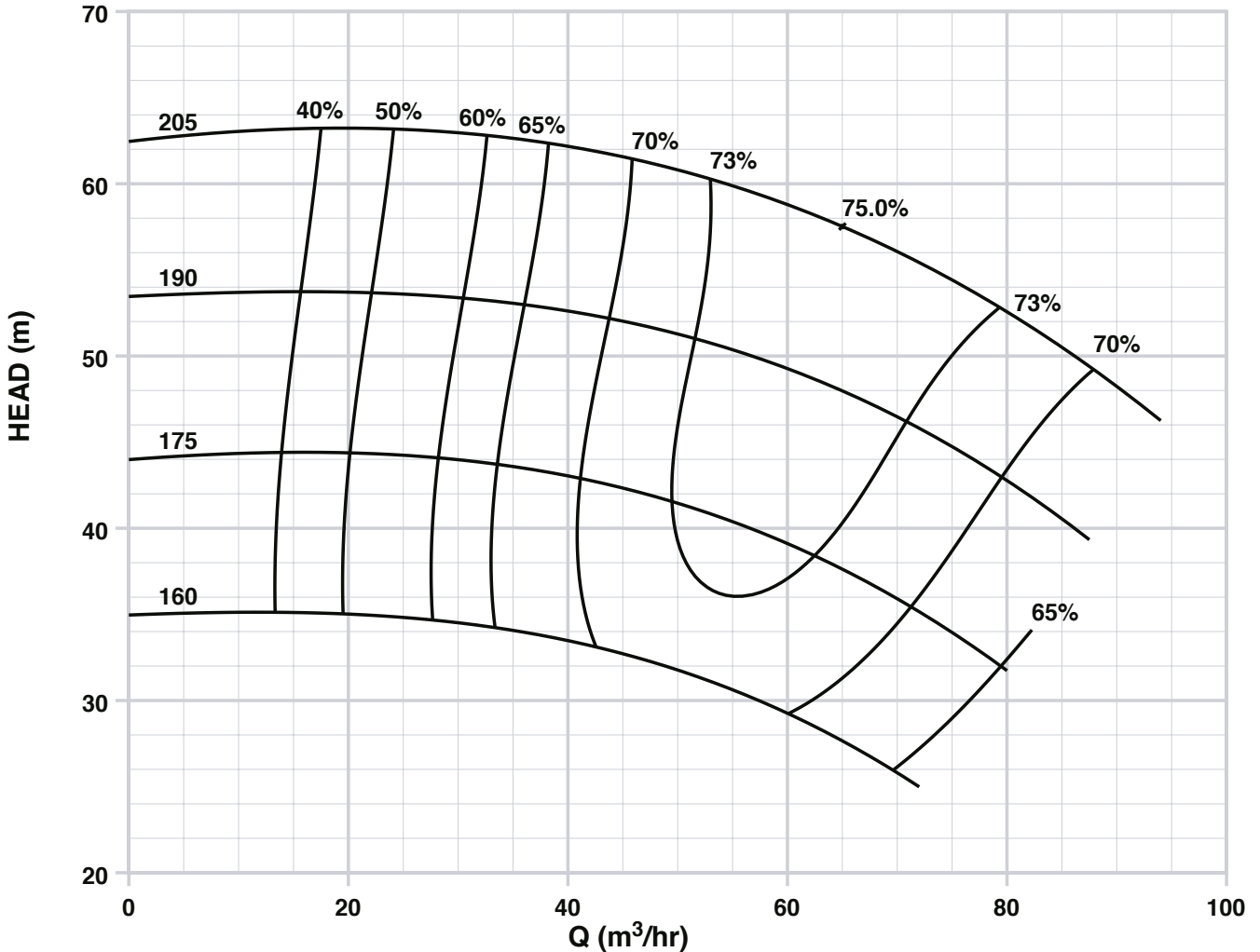

2900

CLT & CLB

MEDIUM-DUTY CENTRIFUGAL CHEMICAL PUMPS TO EN 733 (DIN 24256)



CHARACTERISTIC CURVE

Issue Date
OCTOBER 2005

Suction Diameter
80mm

Discharge Diameter
50mm

DIN 24 256
CLT 50-250

Based on water density 1000 kg/m³ and viscosity 1 cSt.
Head, capacity and efficiency according to ISO Standard 2548: 1973 Annex B

2900 rpm

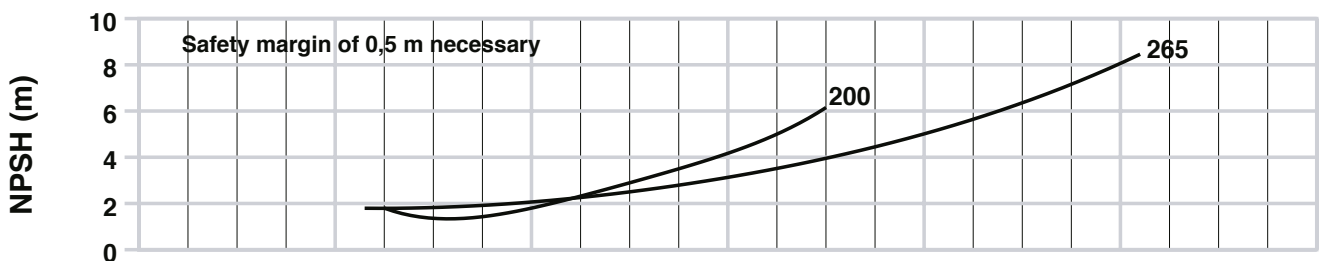
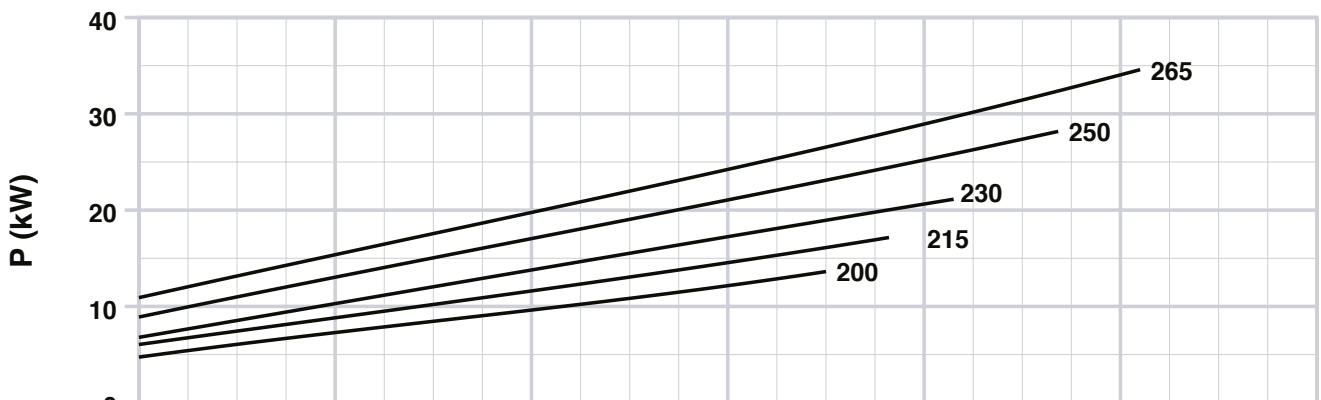
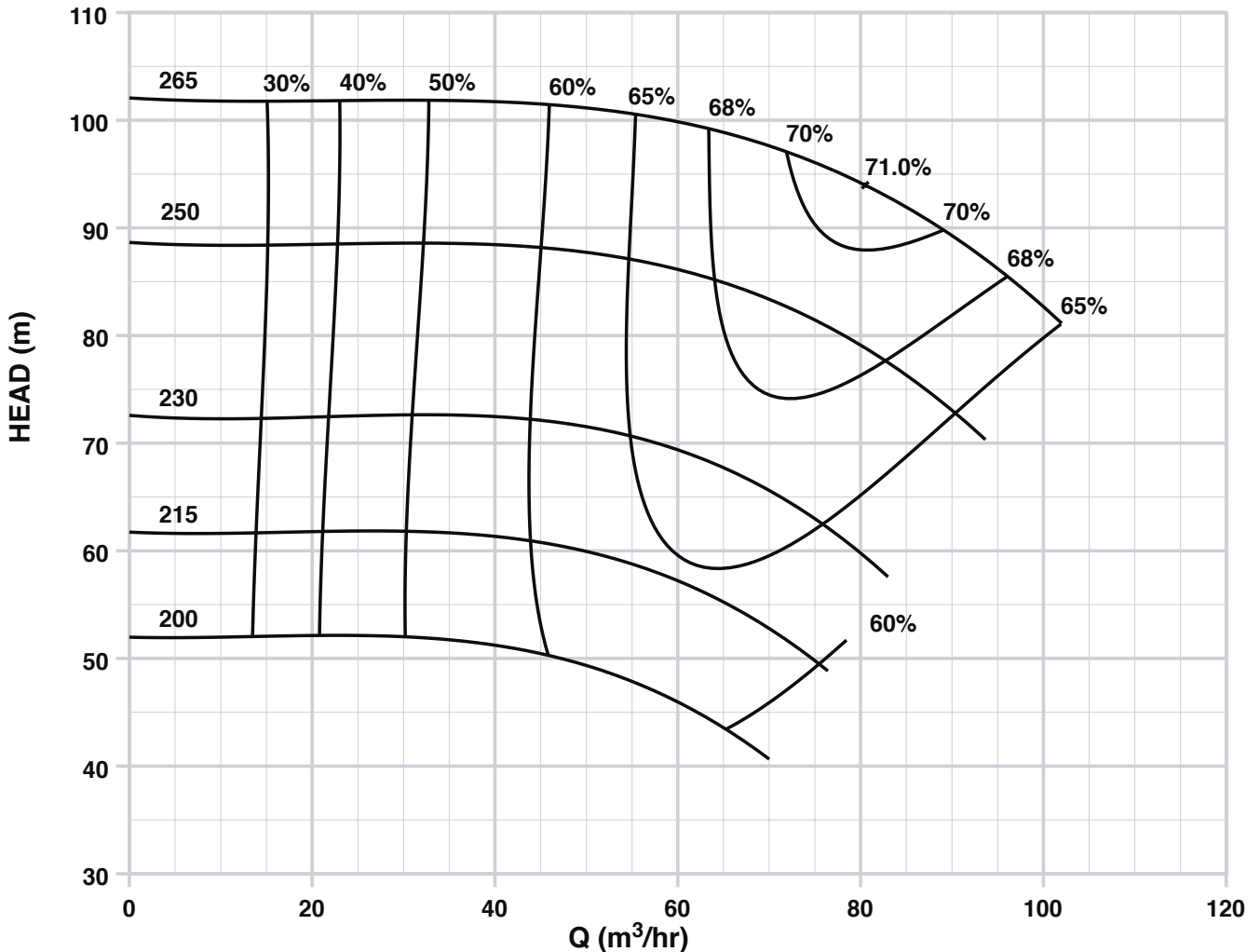

2900

CLT & CLB

MEDIUM-DUTY CENTRIFUGAL CHEMICAL PUMPS TO EN 733 (DIN 24256)



CHARACTERISTIC CURVE

Issue Date
OCTOBER 2005

Suction Diameter
80mm

Discharge Diameter
50mm

DIN 24 256
CLT 50-315

Based on water density 1000 kg/m³ and viscosity 1 cSt.
Head, capacity and efficiency according to ISO Standard 2548: 1973 Annex B

2900 rpm

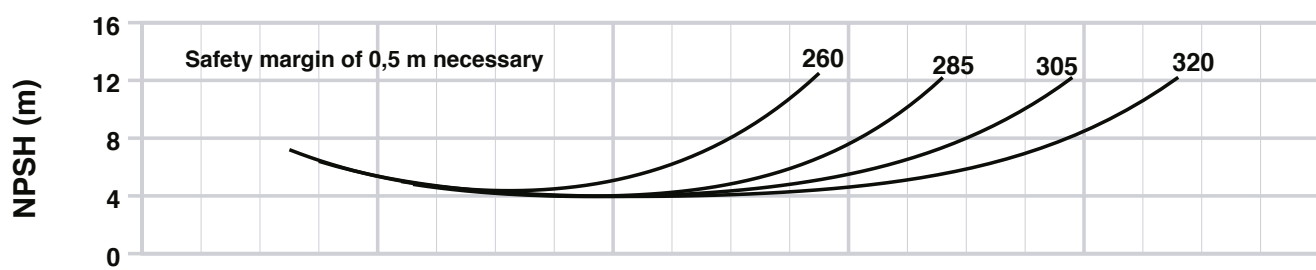
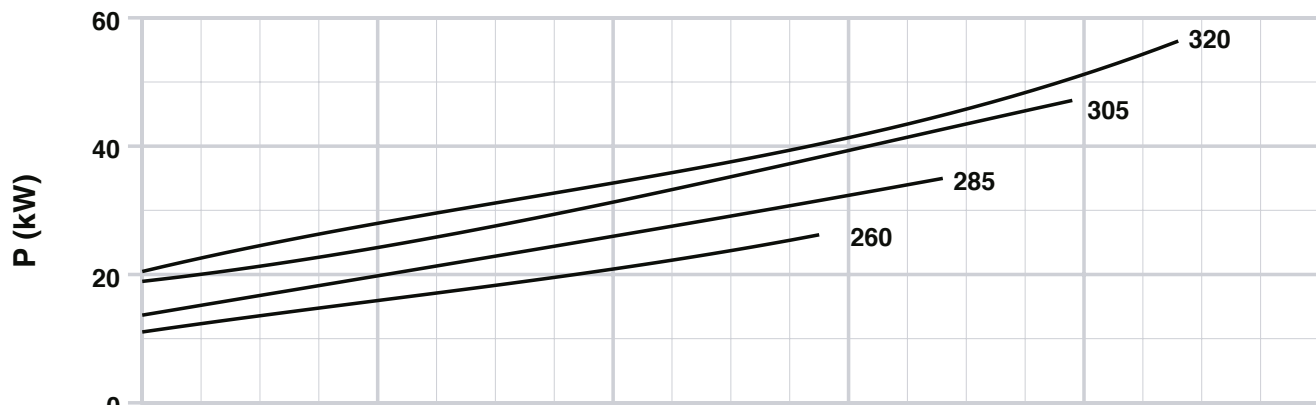
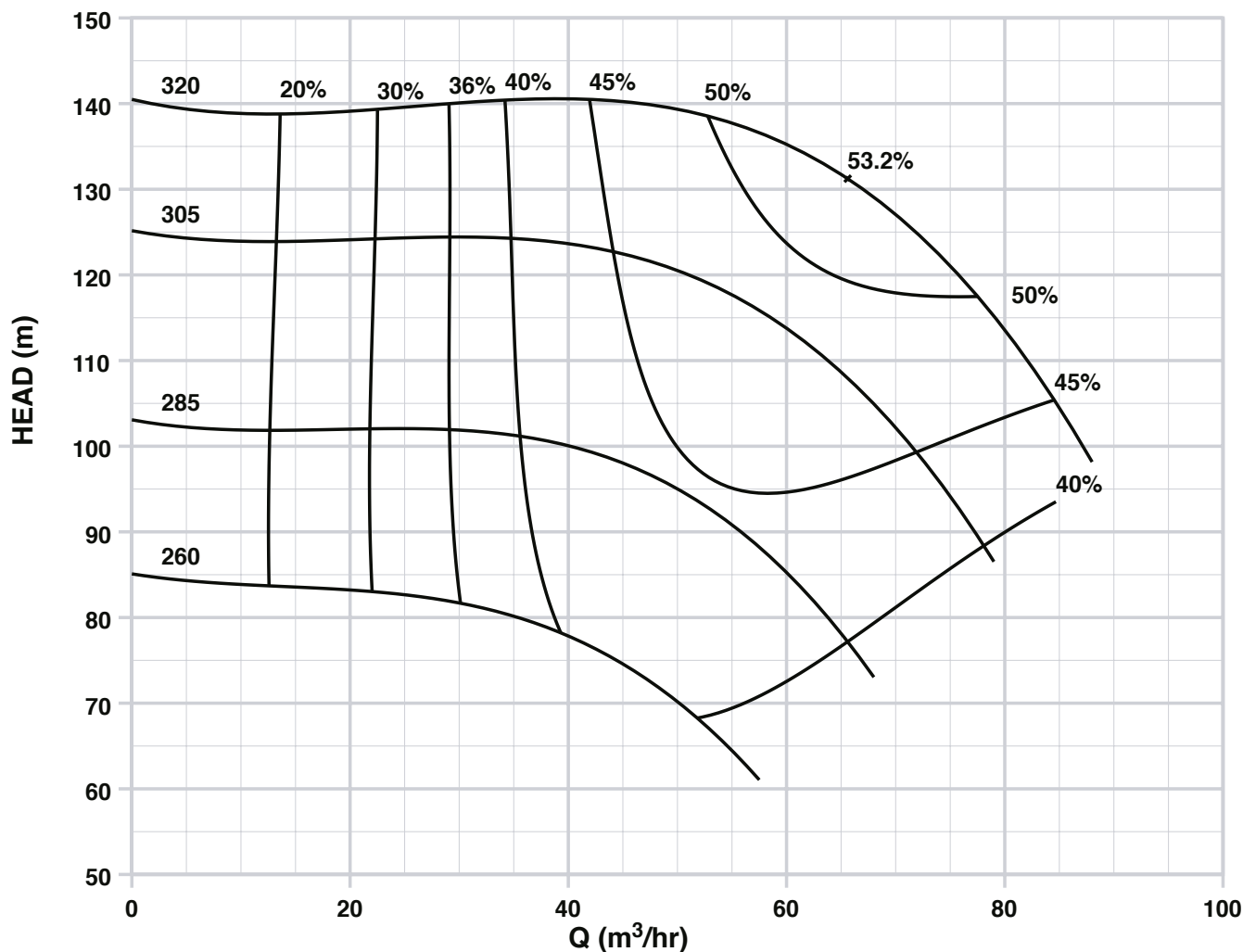

2900

CLT & CLB

MEDIUM-DUTY CENTRIFUGAL CHEMICAL PUMPS TO EN 733 (DIN 24256)



CHARACTERISTIC CURVE

Issue Date
OCTOBER 2005

Suction Diameter
100mm

Discharge Diameter
65mm

DIN 24 256
CLT 65-160

Based on water density 1000 kg/m³ and viscosity 1 cSt.
Head, capacity and efficiency according to ISO Standard 2548: 1973 Annex B

2900 rpm

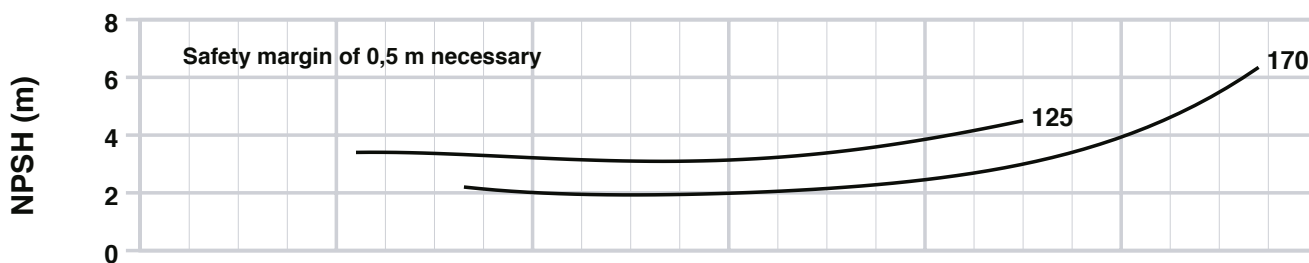
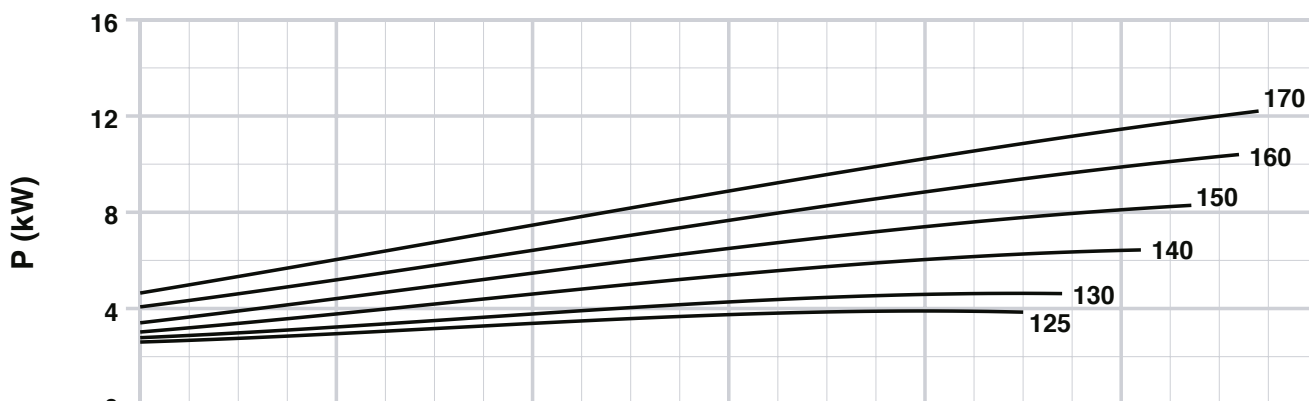
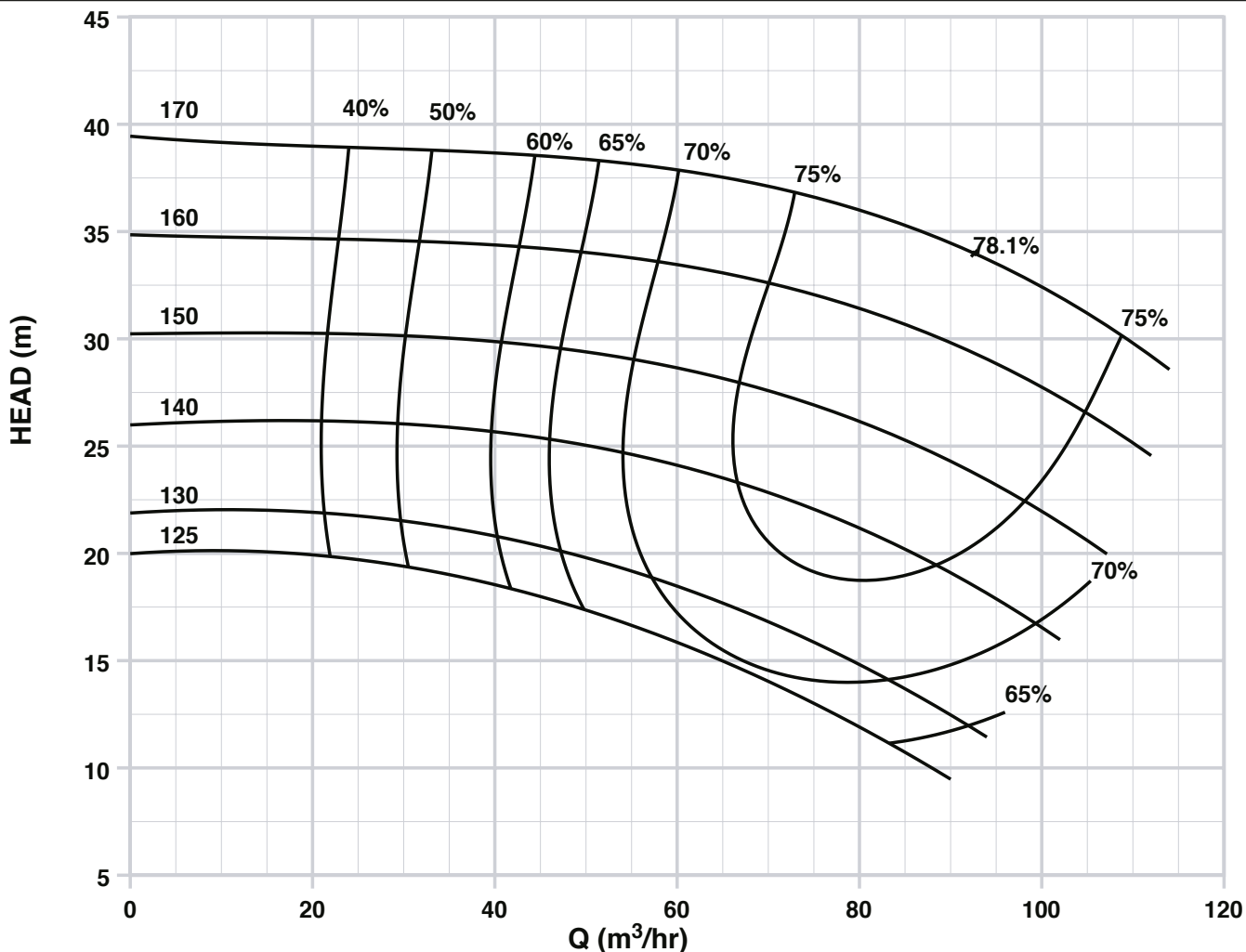

CLT & CLB

CLT & CLB

MEDIUM-DUTY CENTRIFUGAL CHEMICAL PUMPS TO EN 733 (DIN 24256)



CHARACTERISTIC CURVE

Issue Date
OCTOBER 2005

Suction Diameter
100mm

Discharge Diameter
65mm

DIN 24 256
CLT 65-200

Based on water density 1000 kg/m³ and viscosity 1 cSt.
Head, capacity and efficiency according to ISO Standard 2548: 1973 Annex B

2900 rpm

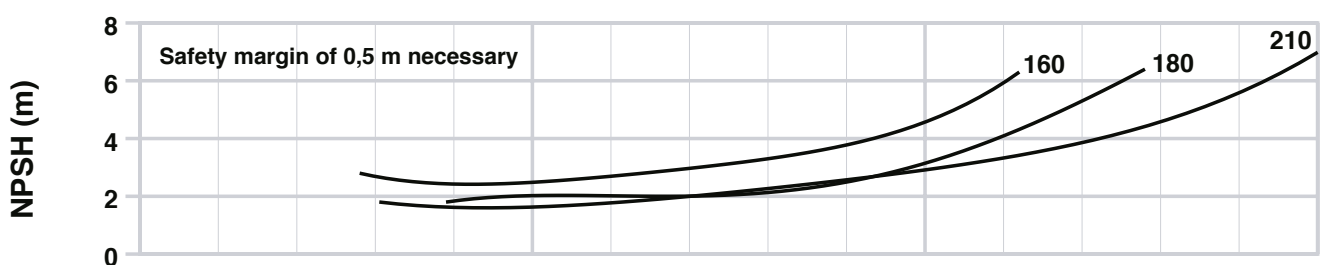
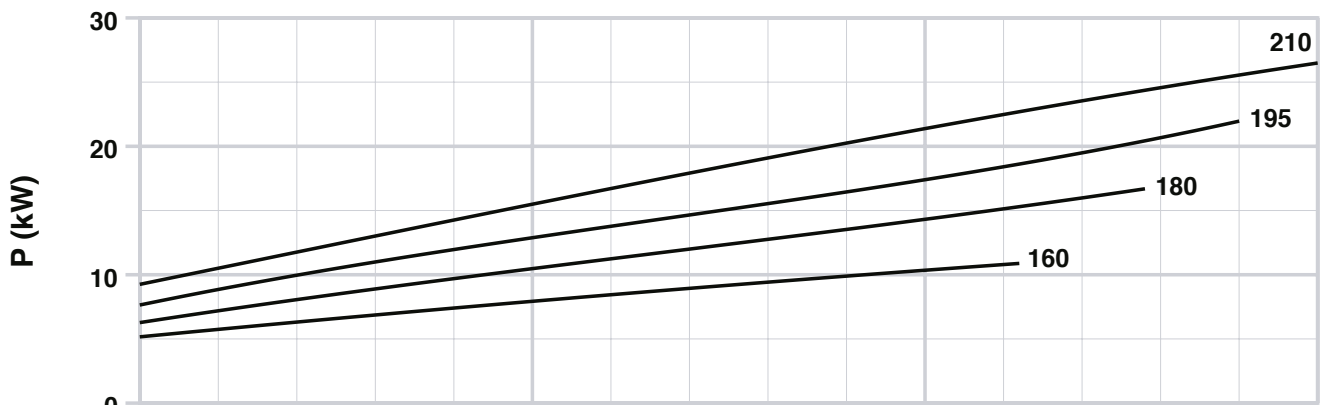
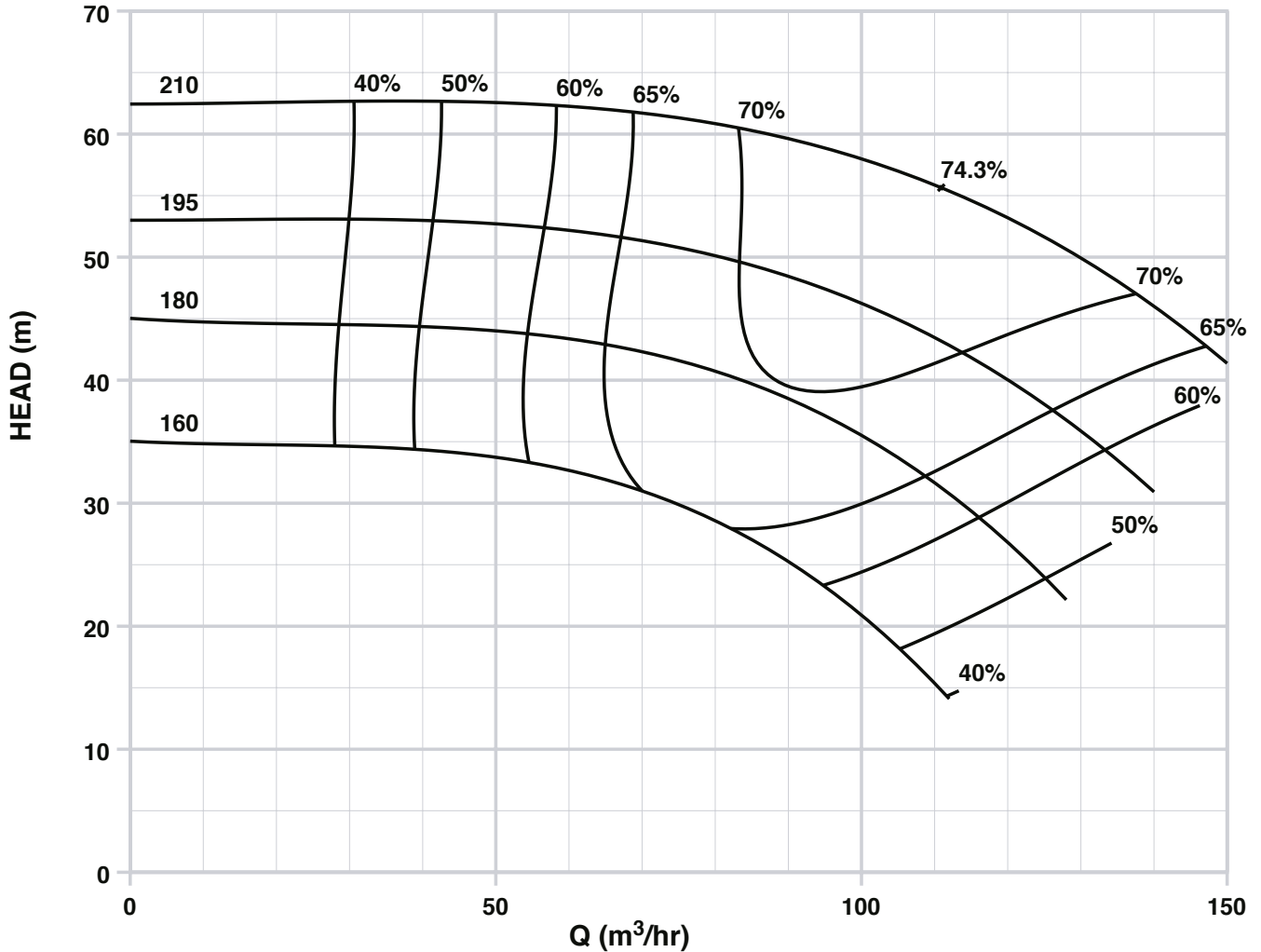

2900

CLT & CLB

MEDIUM-DUTY CENTRIFUGAL CHEMICAL PUMPS TO EN 733 (DIN 24256)



CHARACTERISTIC CURVE

Issue Date
OCTOBER 2005

Suction Diameter
100mm

Discharge Diameter
65mm

DIN 24 256
CLT 65-250

Based on water density 1000 kg/m³ and viscosity 1 cSt.
Head, capacity and efficiency according to ISO Standard 2548: 1973 Annex B

2900 rpm

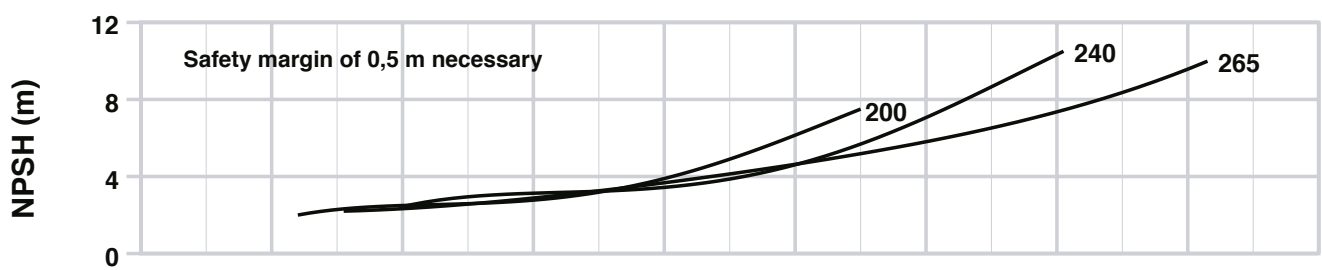
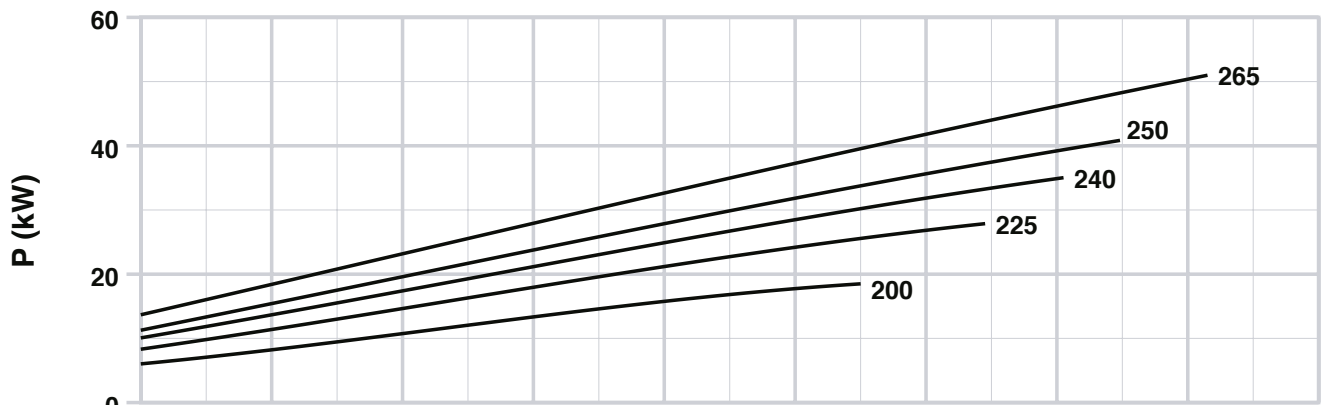
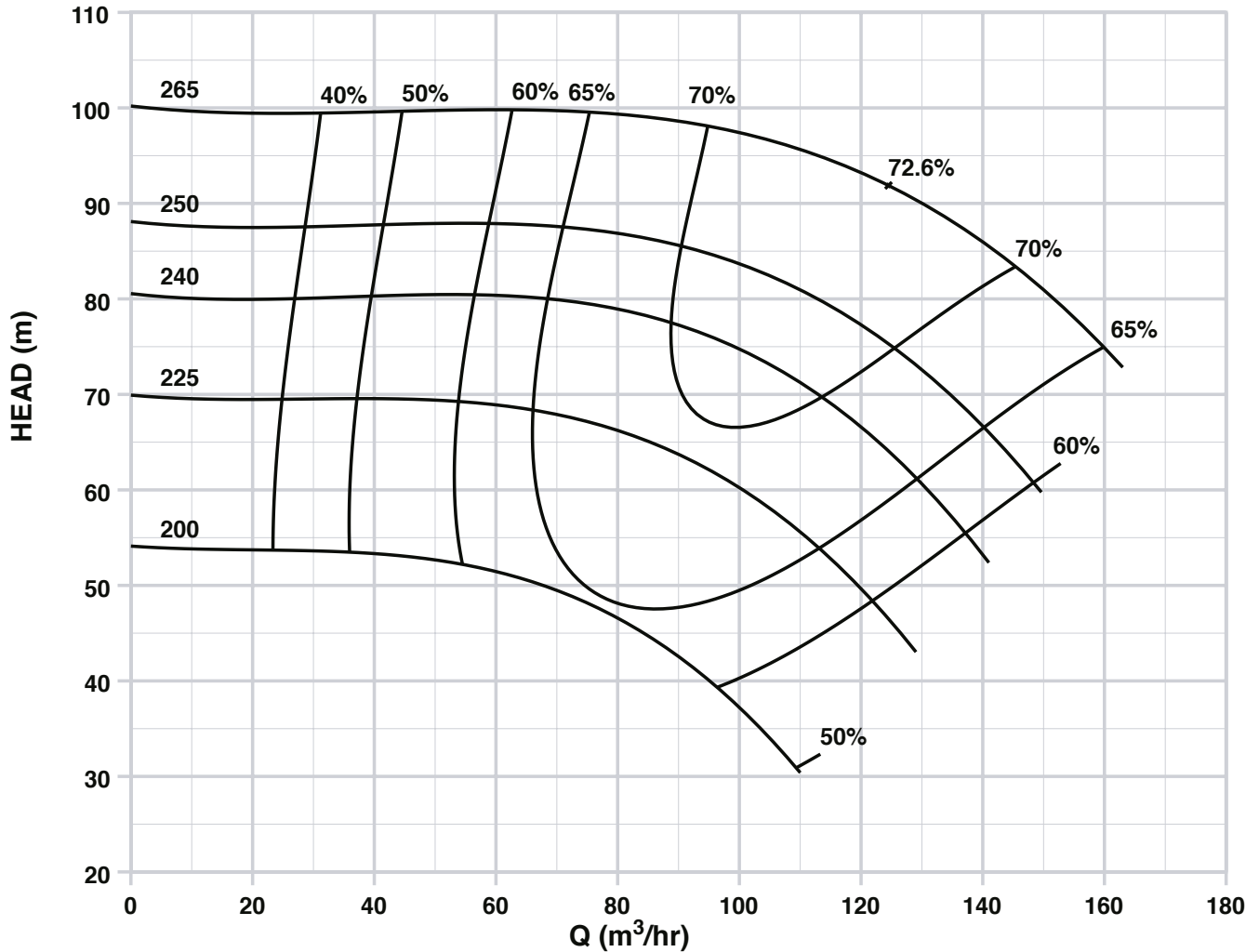

2900

CLT & CLB

MEDIUM-DUTY CENTRIFUGAL CHEMICAL PUMPS TO EN 733 (DIN 24256)



CHARACTERISTIC CURVE

Issue Date
OCTOBER 2005

Suction Diameter
100mm

Discharge Diameter
65mm

DIN 24 256
CLT 65-315

Based on water density 1000 kg/m³ and viscosity 1 cSt.
Head, capacity and efficiency according to ISO Standard 2548: 1973 Annex B

2900 rpm

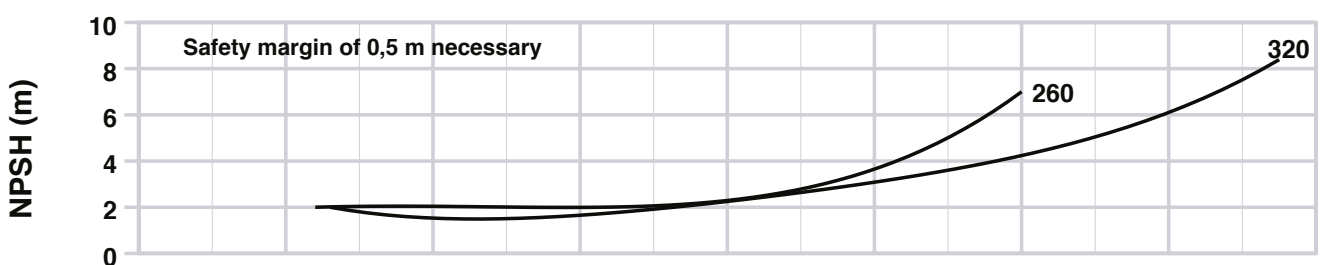
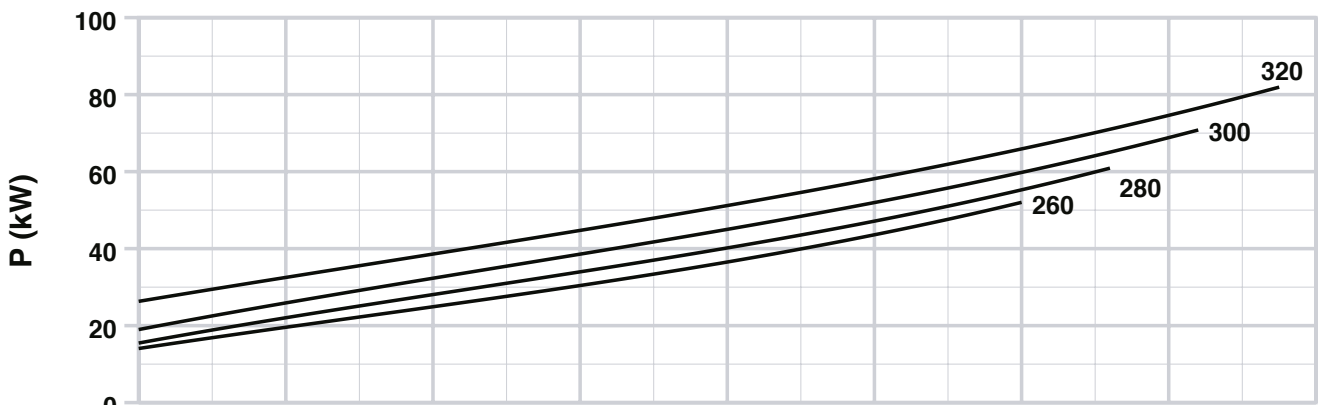
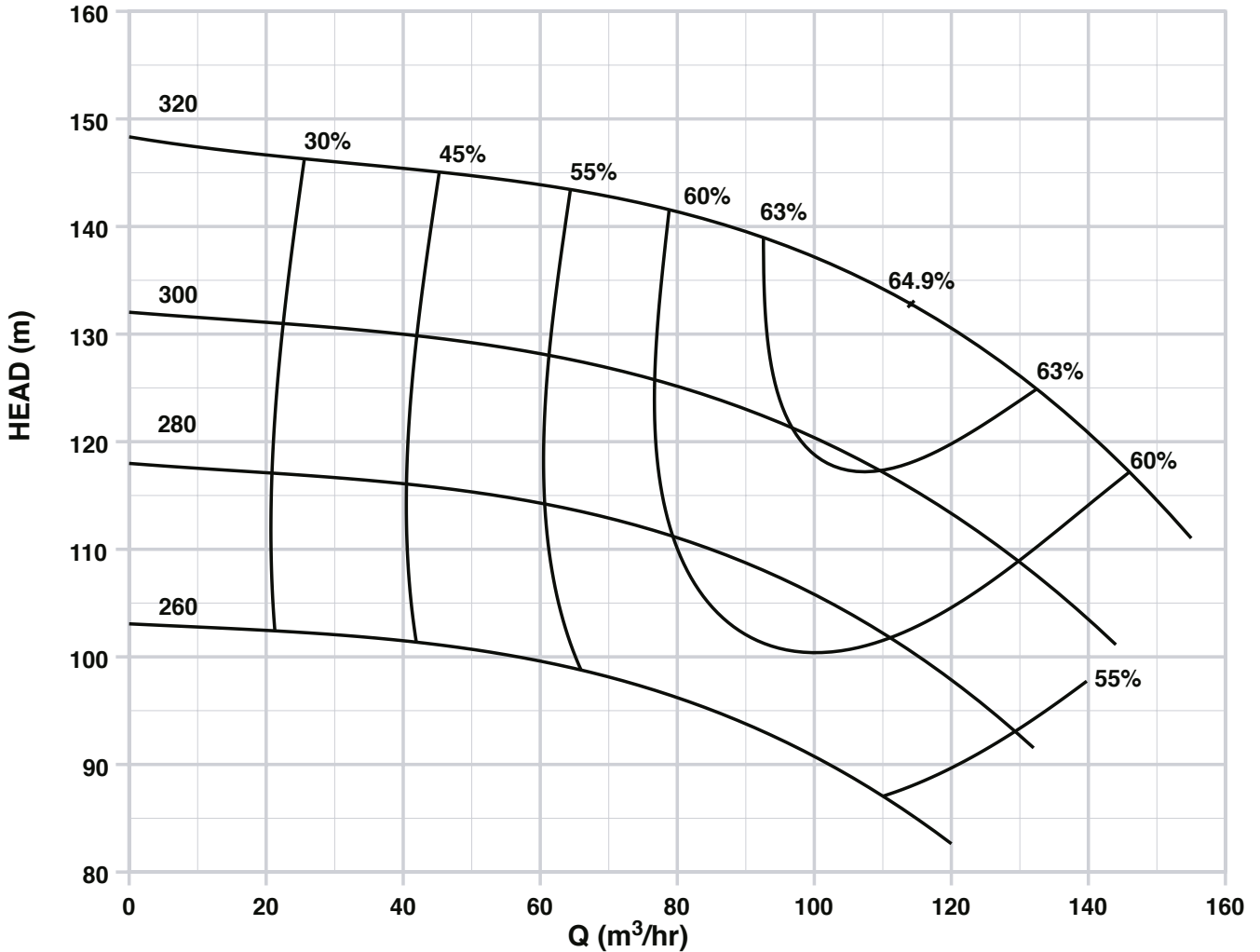

2900

CLT & CLB

MEDIUM-DUTY CENTRIFUGAL CHEMICAL PUMPS TO EN 733 (DIN 24256)



CHARACTERISTIC CURVE

Issue Date
OCTOBER 2005

Suction Diameter
125mm

Discharge Diameter
80mm

DIN 24 256
CLT 80-160

Based on water density 1000 kg/m³ and viscosity 1 cSt.
Head, capacity and efficiency according to ISO Standard 2548: 1973 Annex B

2900 rpm

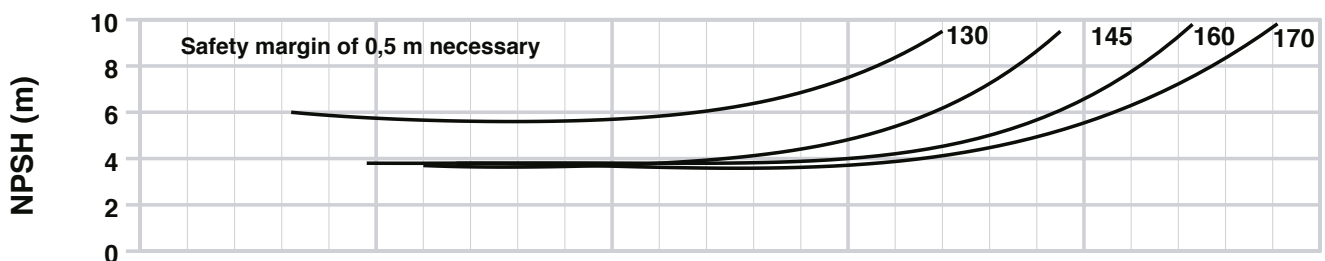
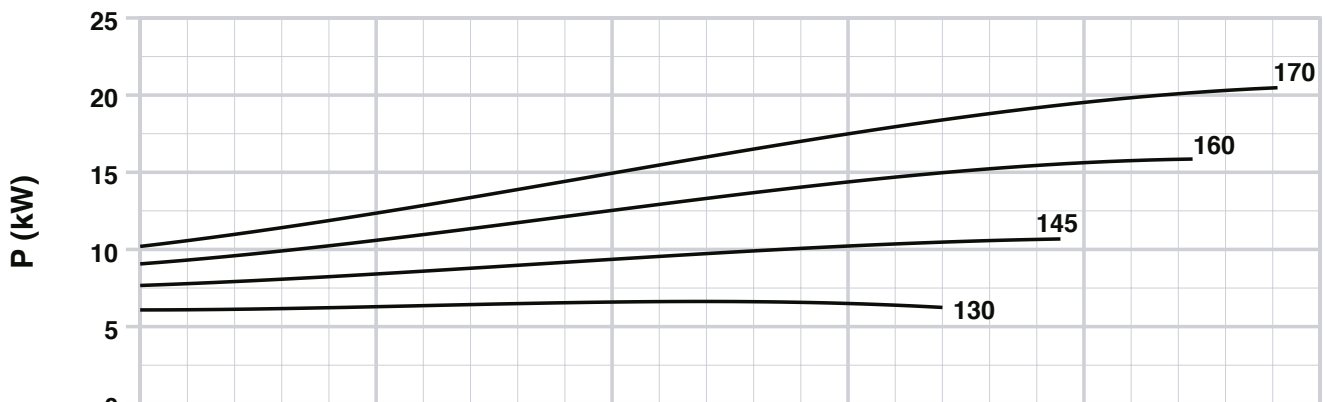
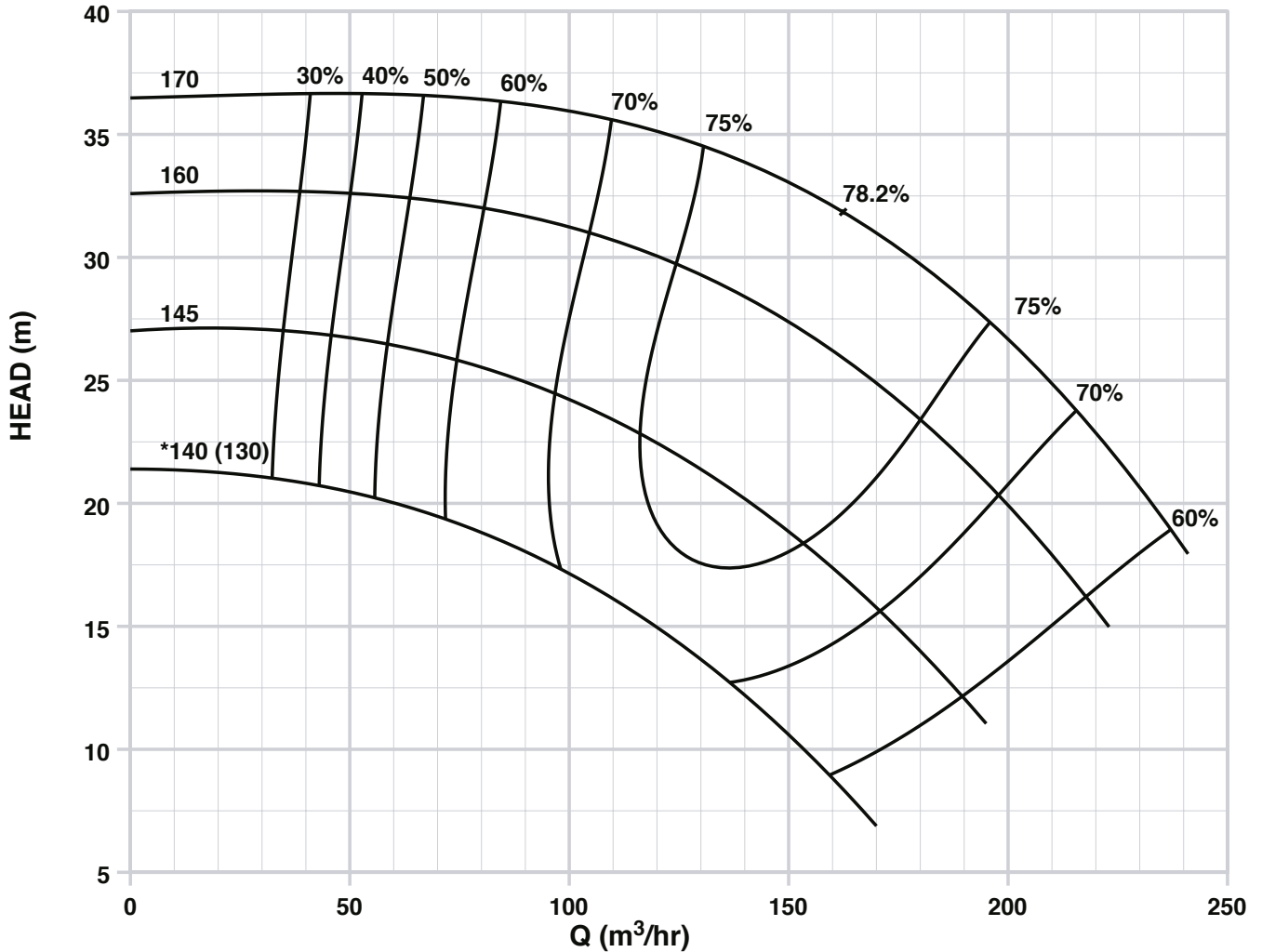

2900

CLT & CLB

MEDIUM-DUTY CENTRIFUGAL CHEMICAL PUMPS TO EN 733 (DIN 24256)



CHARACTERISTIC CURVE

Issue Date
OCTOBER 2005

Suction Diameter
125mm

Discharge Diameter
80mm

DIN 24 256
CLT 80-200

Based on water density 1000 kg/m³ and viscosity 1 cSt.
Head, capacity and efficiency according to ISO Standard 2548: 1973 Annex B

2900 rpm

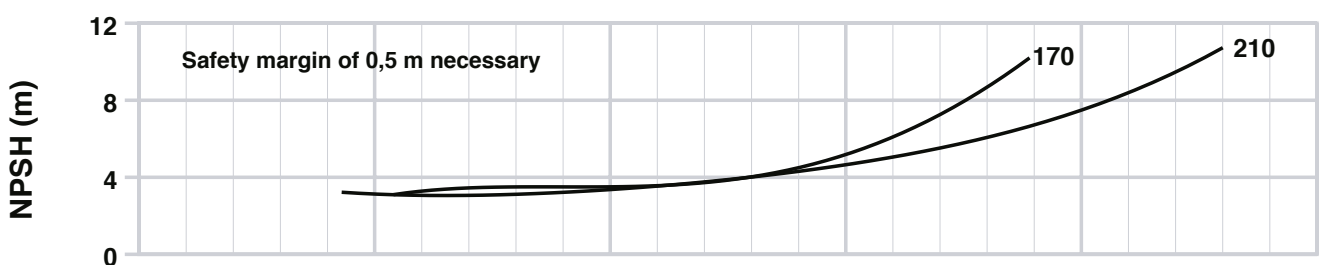
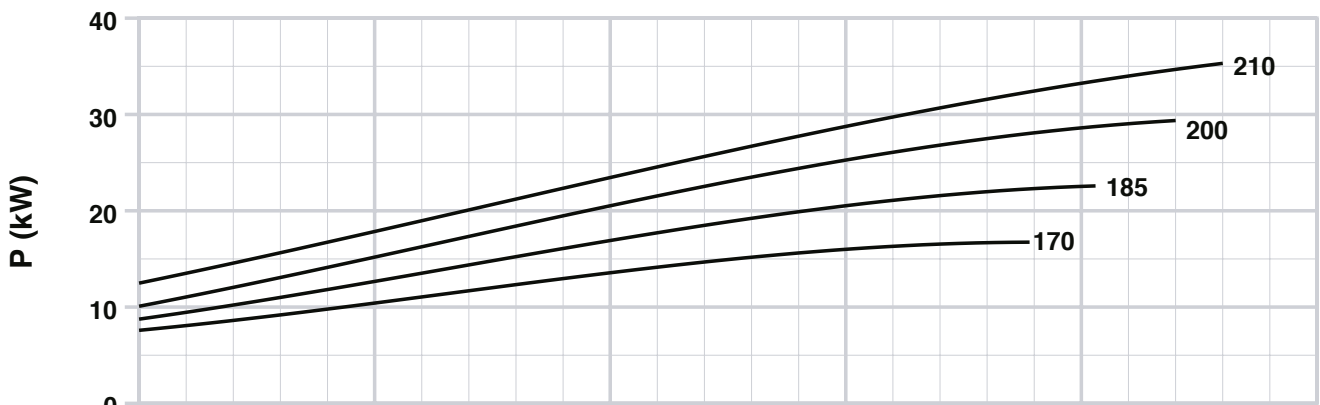
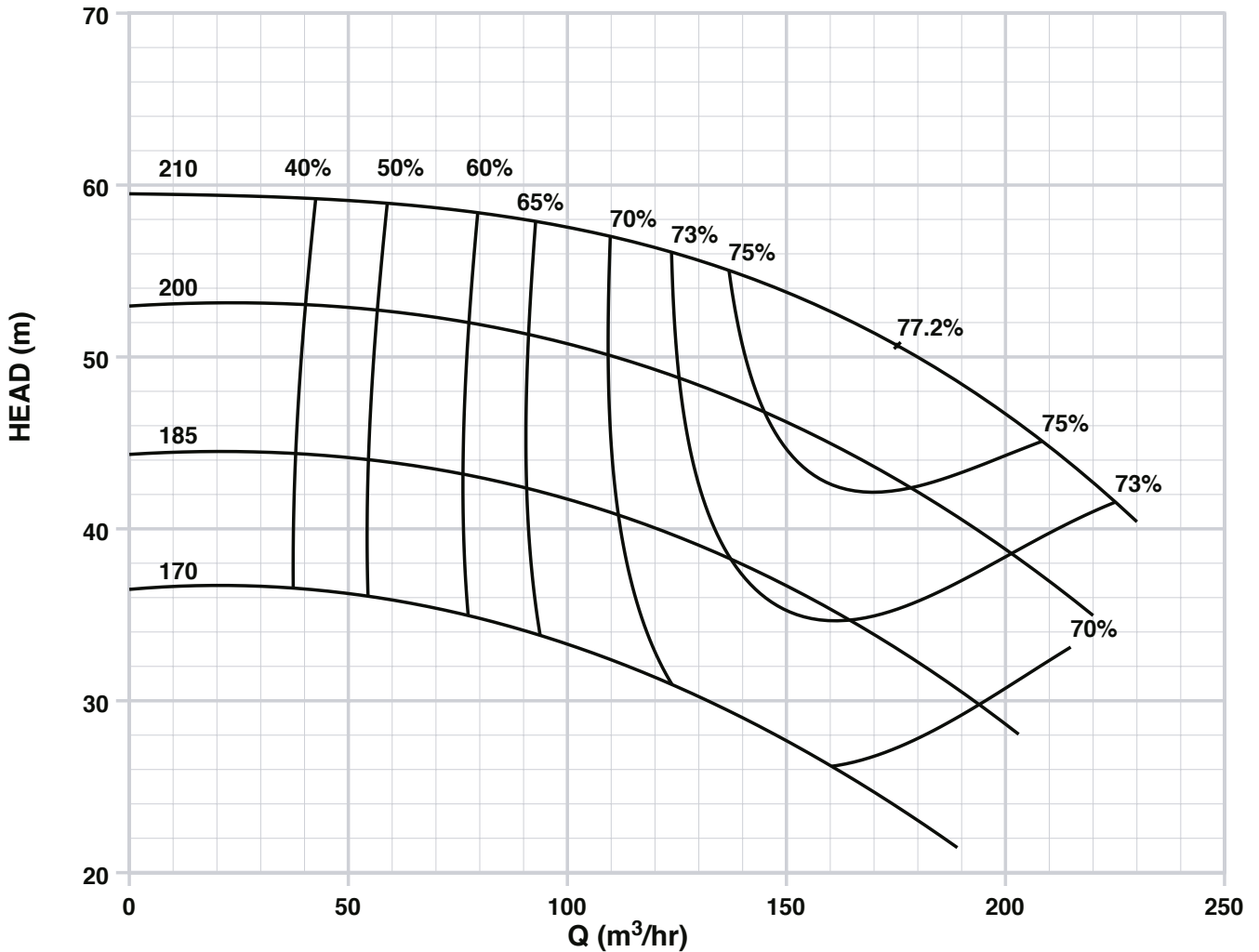

2900

CLT & CLB

MEDIUM-DUTY CENTRIFUGAL CHEMICAL PUMPS TO EN 733 (DIN 24256)



CHARACTERISTIC CURVE

Issue Date
OCTOBER 2005

Suction Diameter
125mm

Discharge Diameter
80mm

DIN 24 256
CLT 80-250

Based on water density 1000 kg/m³ and viscosity 1 cSt.
Head, capacity and efficiency according to ISO Standard 2548: 1973 Annex B

2900 rpm

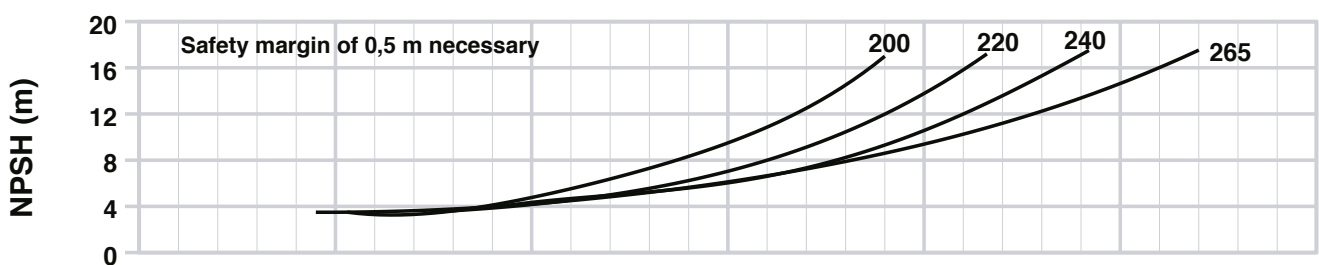
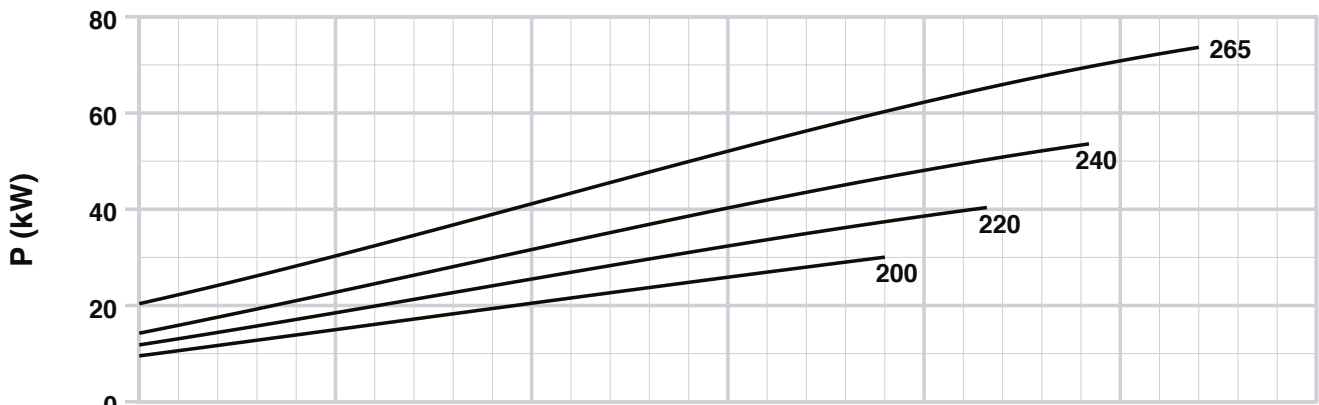
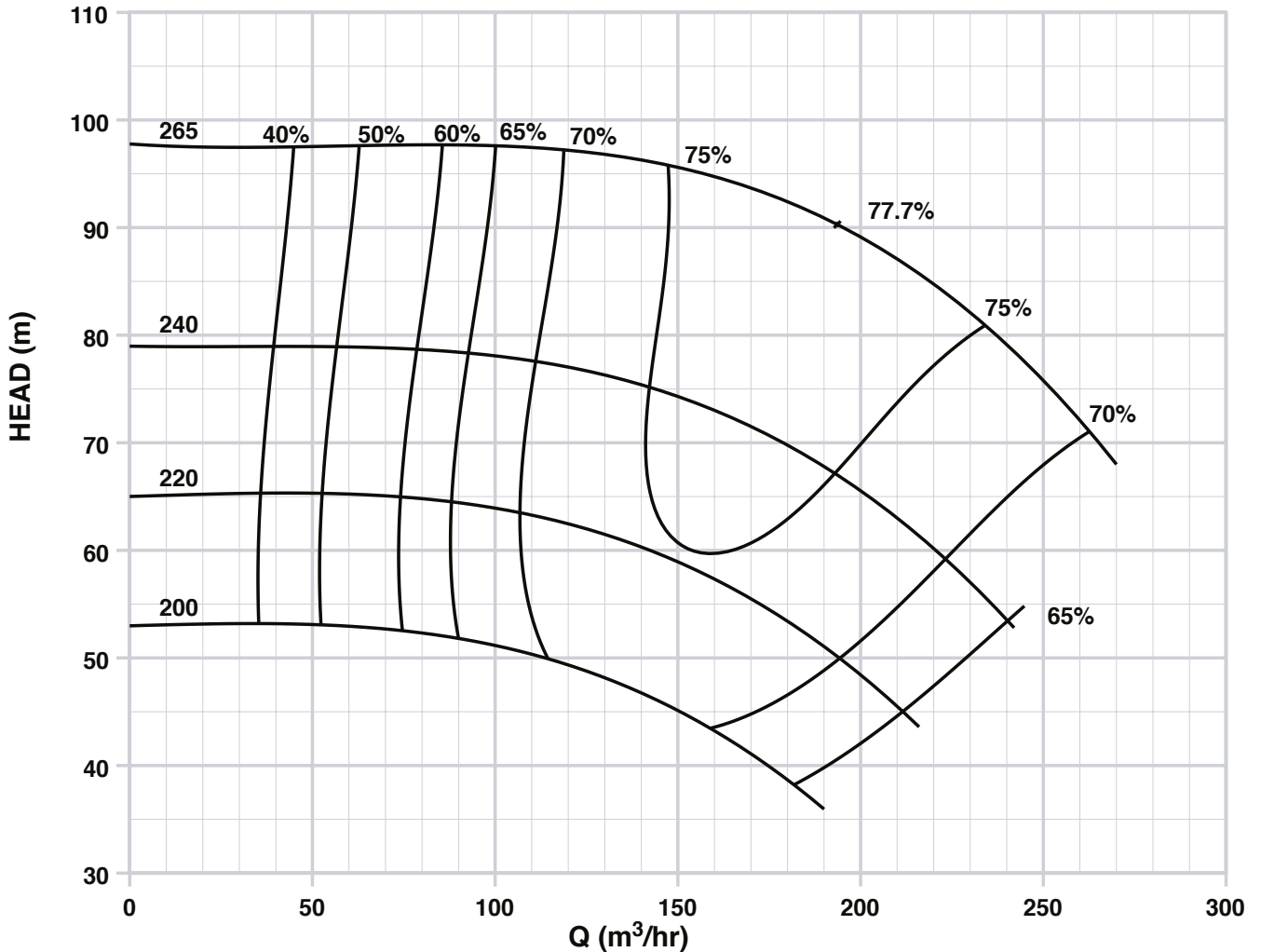

2900

CLT & CLB

MEDIUM-DUTY CENTRIFUGAL CHEMICAL PUMPS TO EN 733 (DIN 24256)

	CHARACTERISTIC CURVE		DIN 24 256	
	Issue Date OCTOBER 2005	Suction Diameter 125mm	Discharge Diameter 80mm	CLT 80-315
	Based on water density 1000 kg/m ³ and viscosity 1 cSt. Head, capacity and efficiency according to ISO Standard 2548: 1973 Annex B			2900 rpm

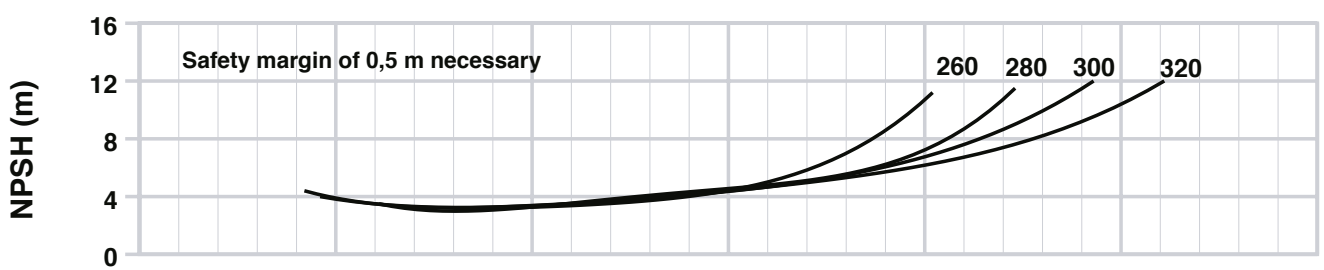
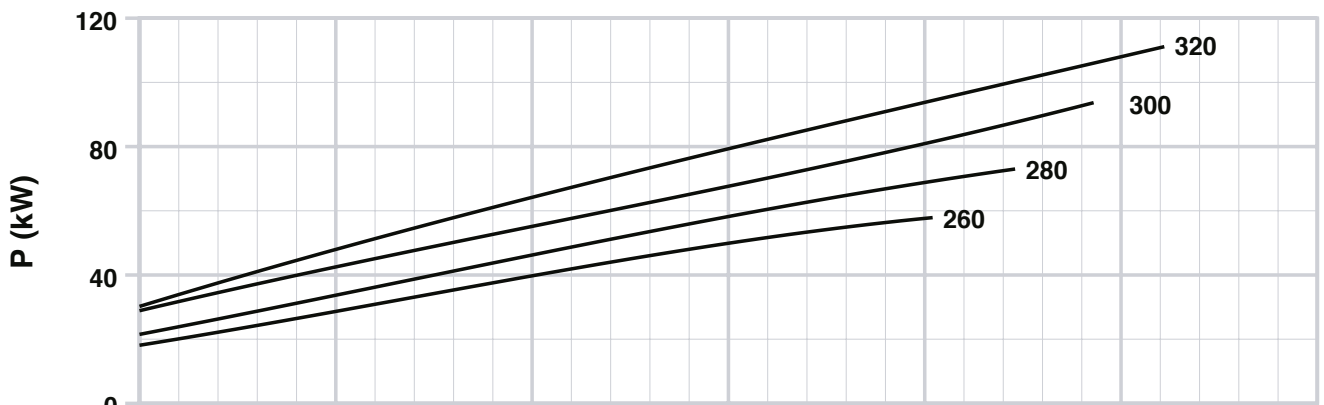
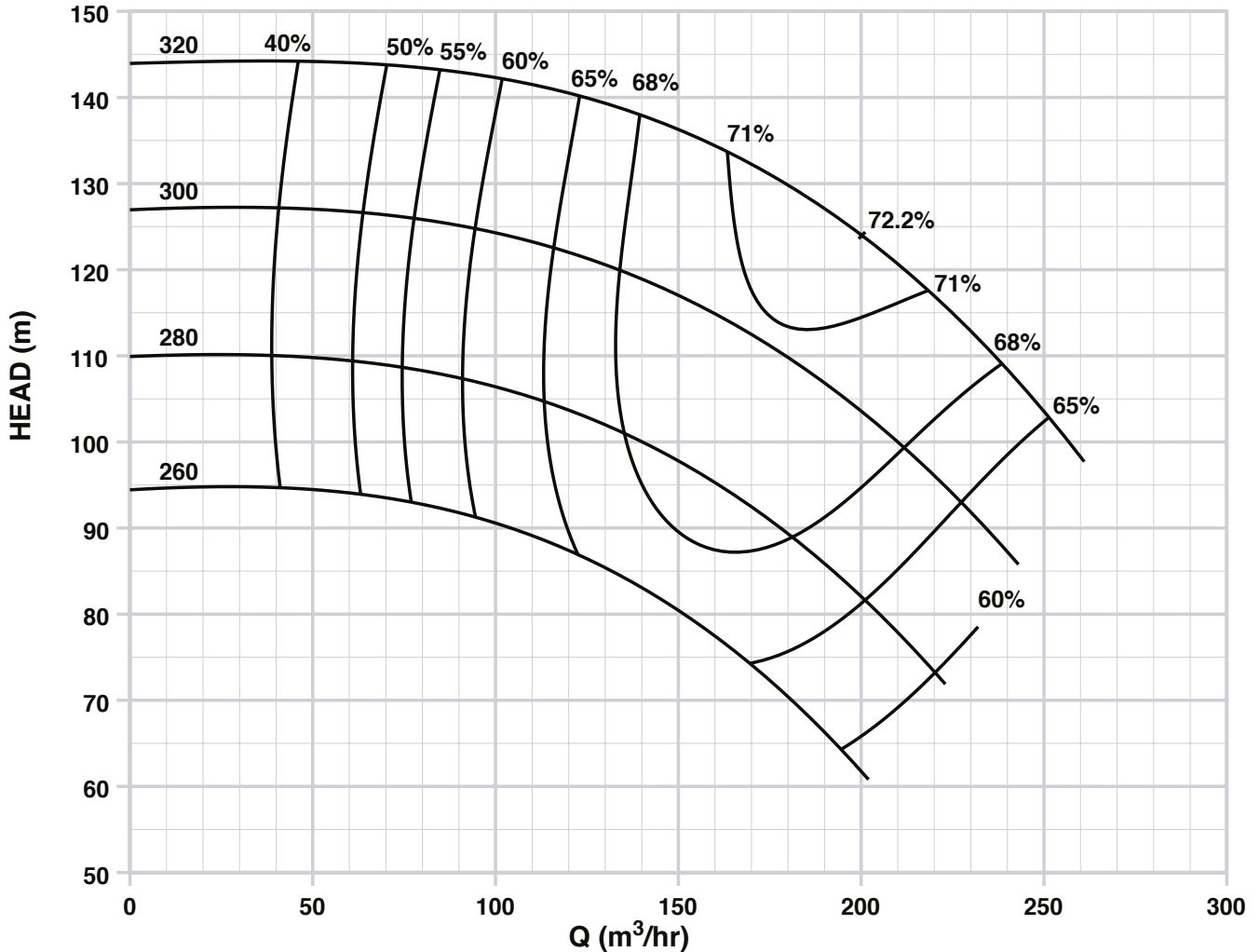

2900

CLT & CLB

MEDIUM-DUTY CENTRIFUGAL CHEMICAL PUMPS TO EN 733 (DIN 24256)



CHARACTERISTIC CURVE

Issue Date
OCTOBER 2005

Suction Diameter
125mm

Discharge Diameter
100mm

DIN 24 256
CLT 100-200

Based on water density 1000 kg/m³ and viscosity 1 cSt.
Head, capacity and efficiency according to ISO Standard 2548: 1973 Annex B

2900 rpm

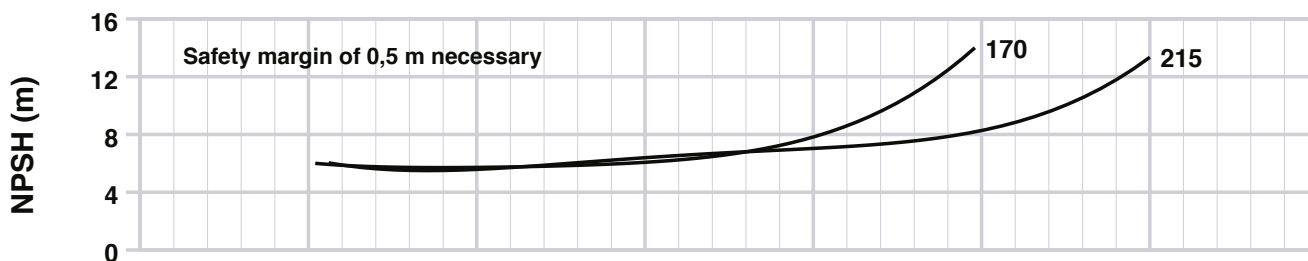
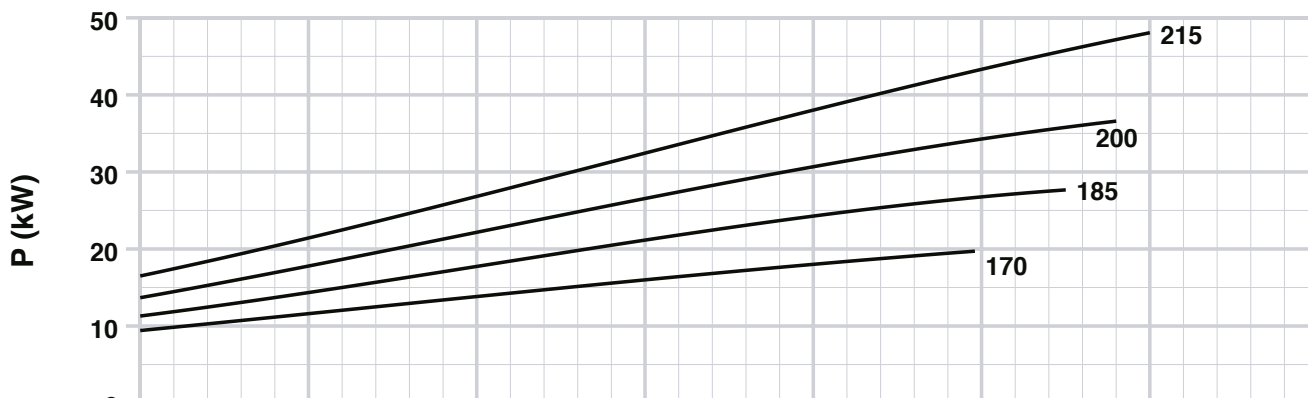
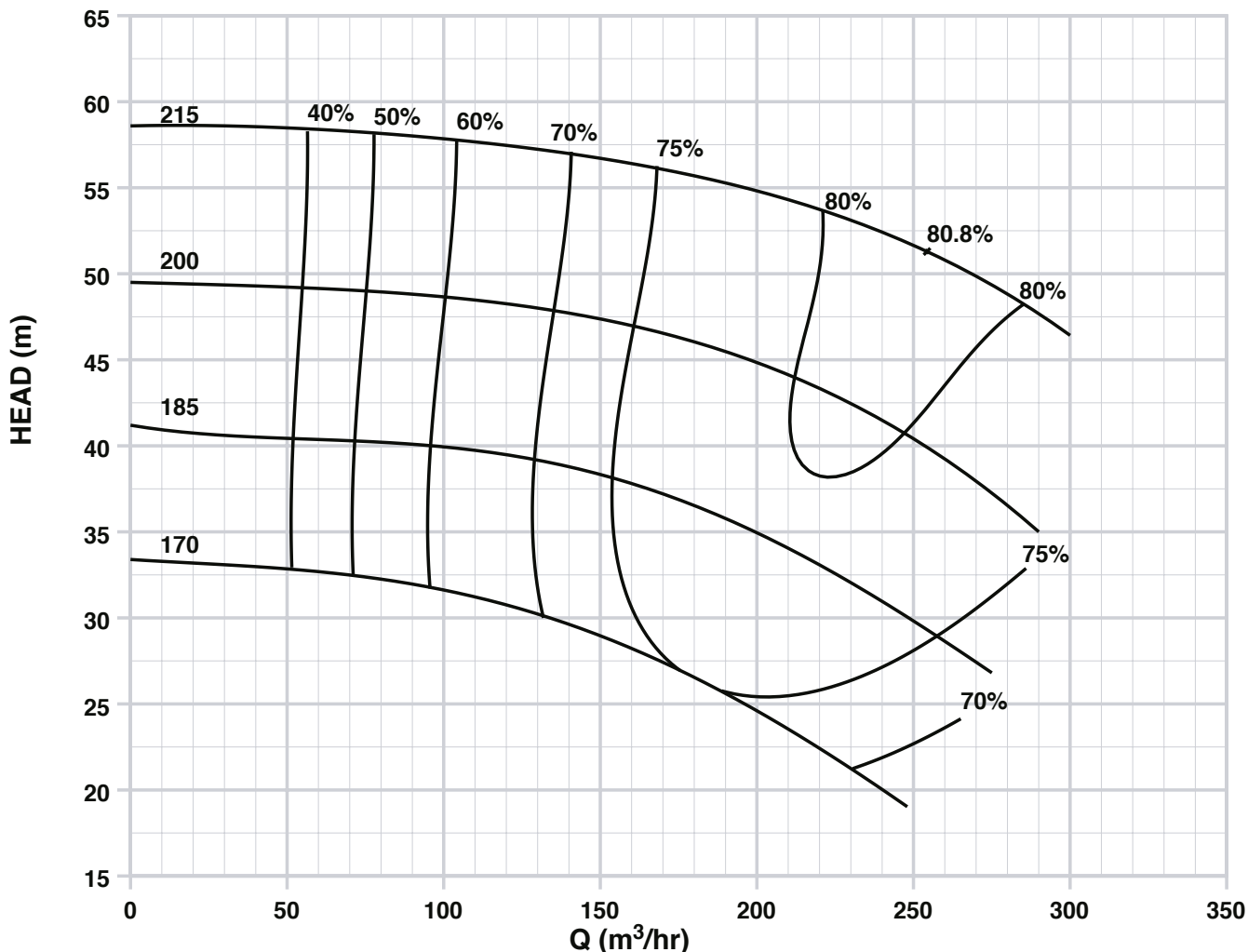

2900

CLT & CLB

MEDIUM-DUTY CENTRIFUGAL CHEMICAL PUMPS TO EN 733 (DIN 24256)



CHARACTERISTIC CURVE

Issue Date
OCTOBER 2005

Suction Diameter
125mm

Discharge Diameter
100mm

DIN 24 256
CLT 100-250

Based on water density 1000 kg/m³ and viscosity 1 cSt.
Head, capacity and efficiency according to ISO Standard 2548: 1973 Annex B

2900 rpm

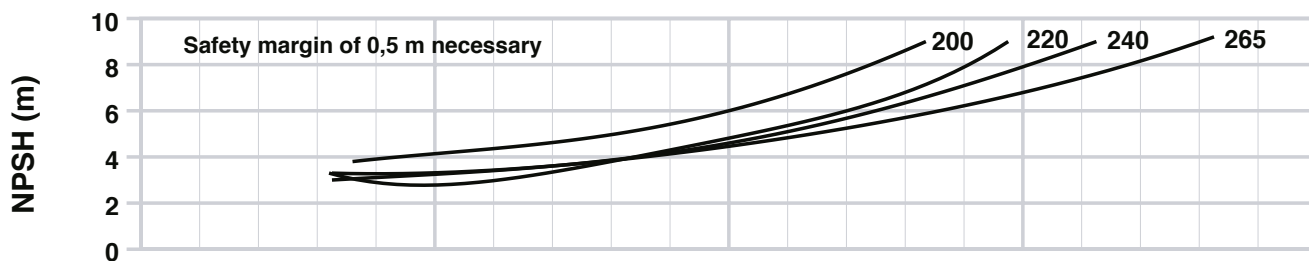
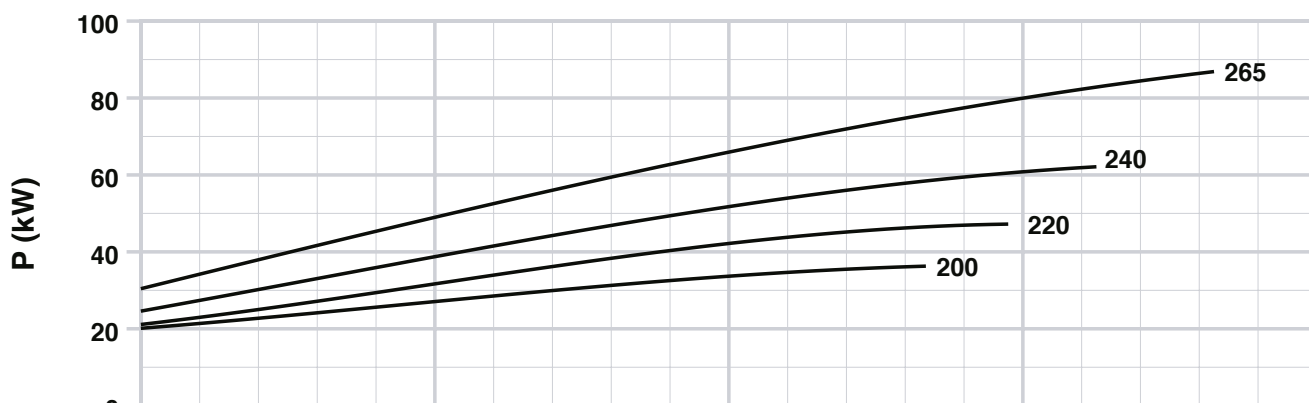
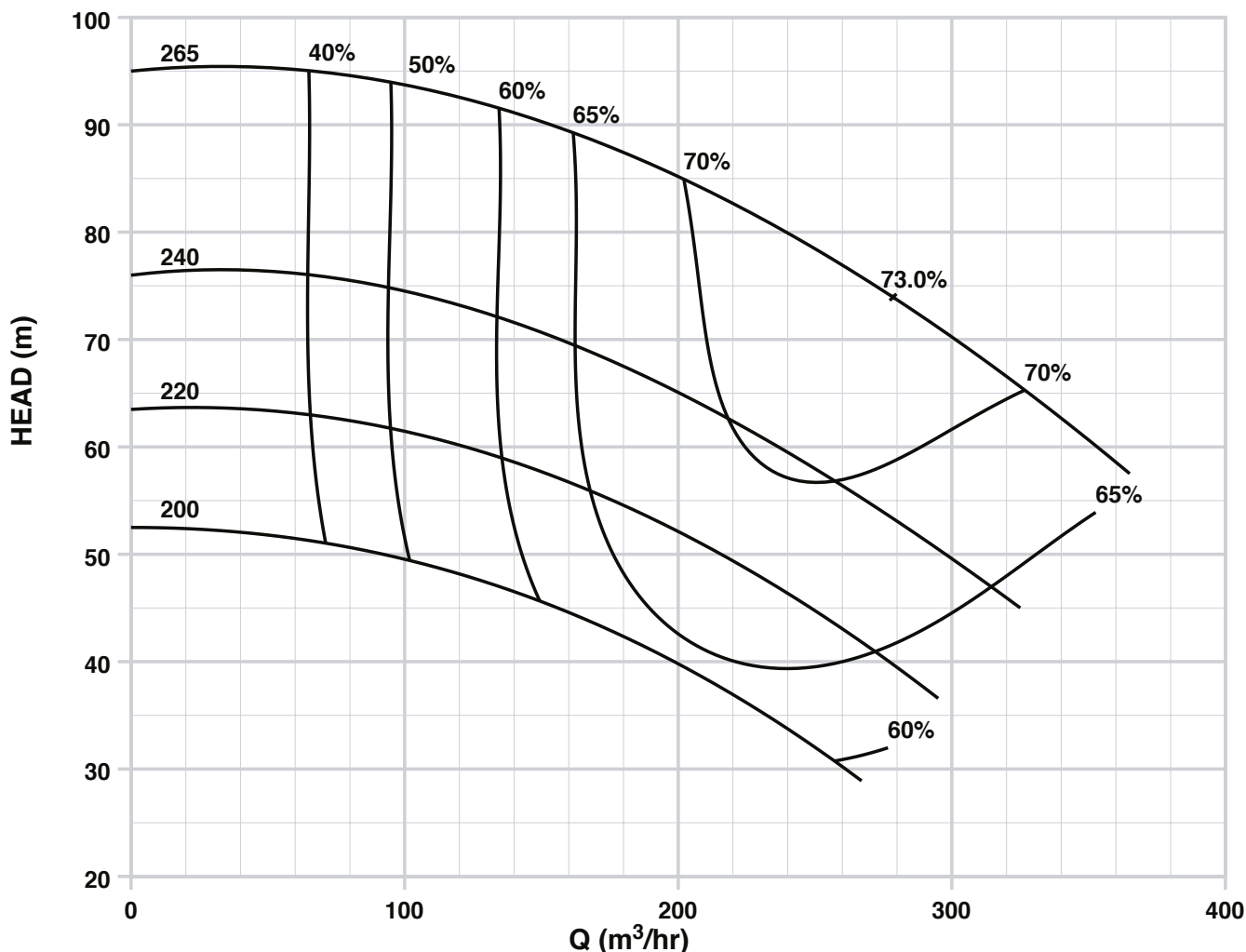

2900

CLT & CLB

MEDIUM-DUTY CENTRIFUGAL CHEMICAL PUMPS TO EN 733 (DIN 24256)



CHARACTERISTIC CURVE

Issue Date
OCTOBER 2005

Suction Diameter
125mm

Discharge Diameter
100mm

DIN 24 256
CLT 100-315

Based on water density 1000 kg/m³ and viscosity 1 cSt.
Head, capacity and efficiency according to ISO Standard 2548: 1973 Annex B

2900 rpm

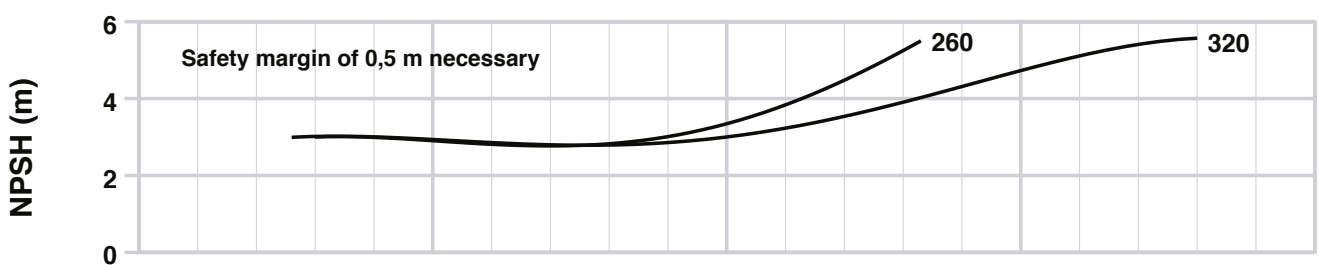
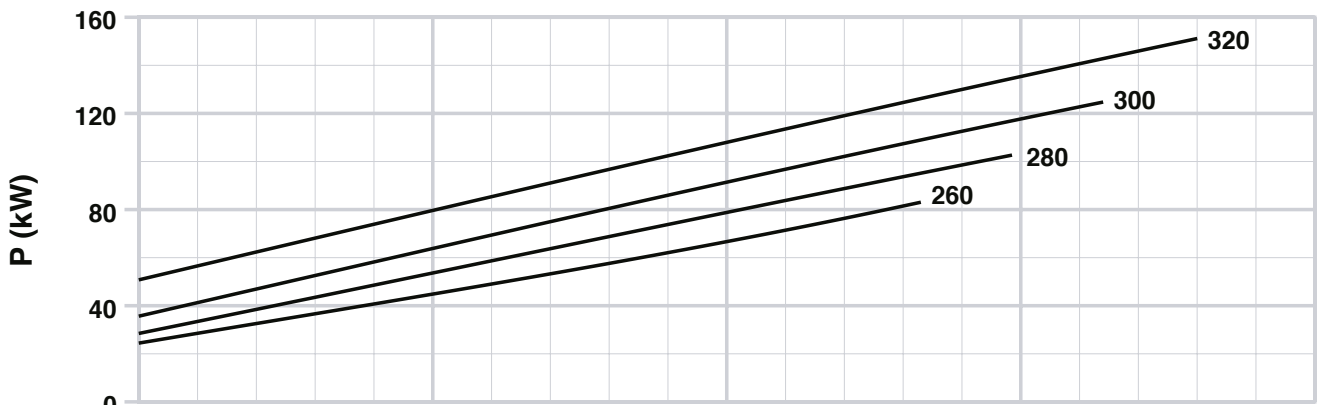
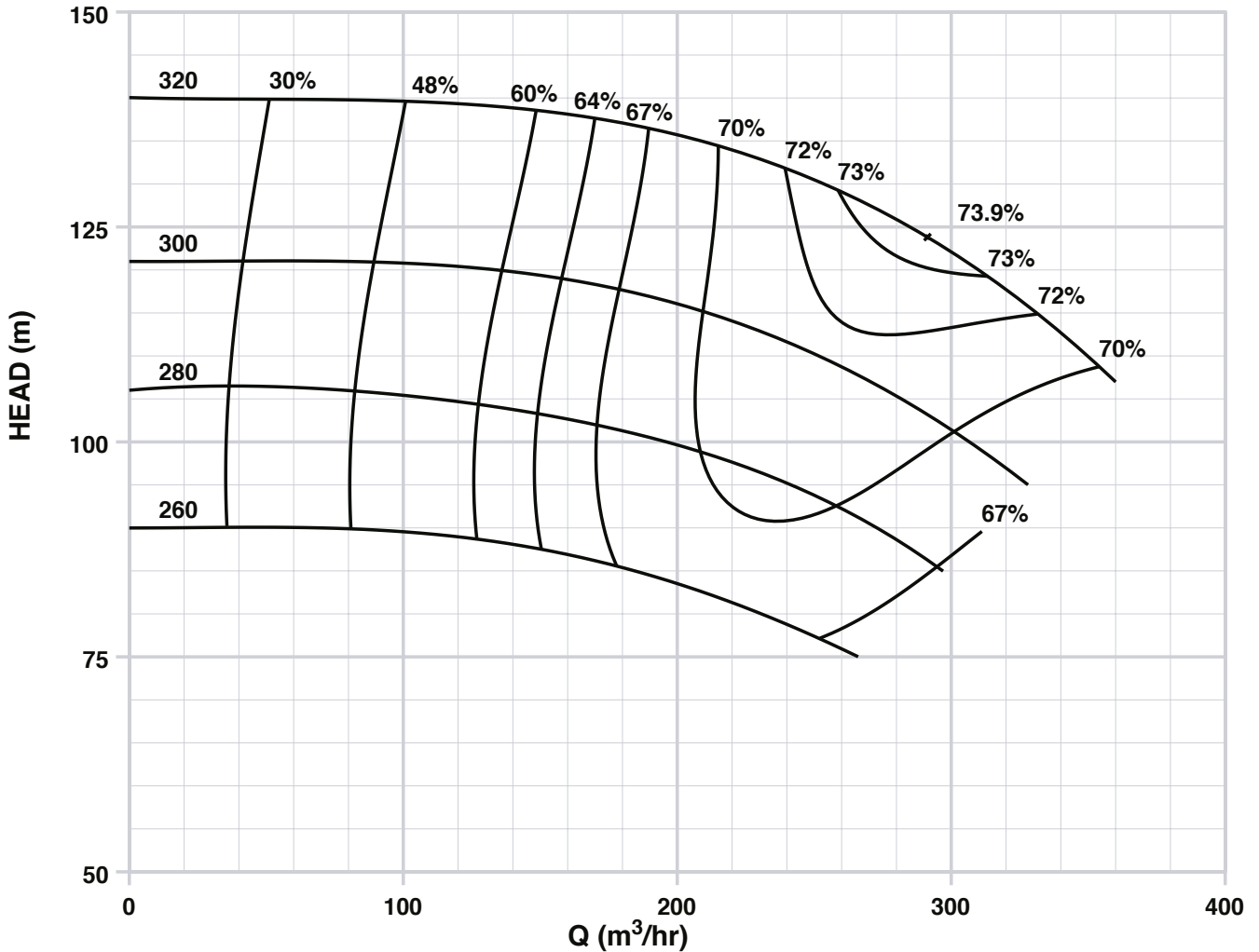

2900



RAW

Rapid Allweiler Way

COMMUNICATION

- *Define Requirement*
- *Provide Solution*
- *Order Confirmation/Weekly Feedback*
- *Utilize MRP and KANBAN processes to ensure alignment between all departments*

QUALITY

- *CBS Quality Management System*
- *Continuous QC Inspection in Manufacturing Process*
- *External suppliers vetted and quality checked*

COMMITMENT

Our Core Value System:

-  *Can Do*
-  *Trust*
-  *Family*
-  *Growth Orientated*
-  *Passionate*

SATISFACTION

- *Delivered as Promised, Quality and on Time*
- *Engage in ongoing feedback*
 - *Once Product is Delivered*
 - *When Product is Commissioned*

" Delivered as Promised "

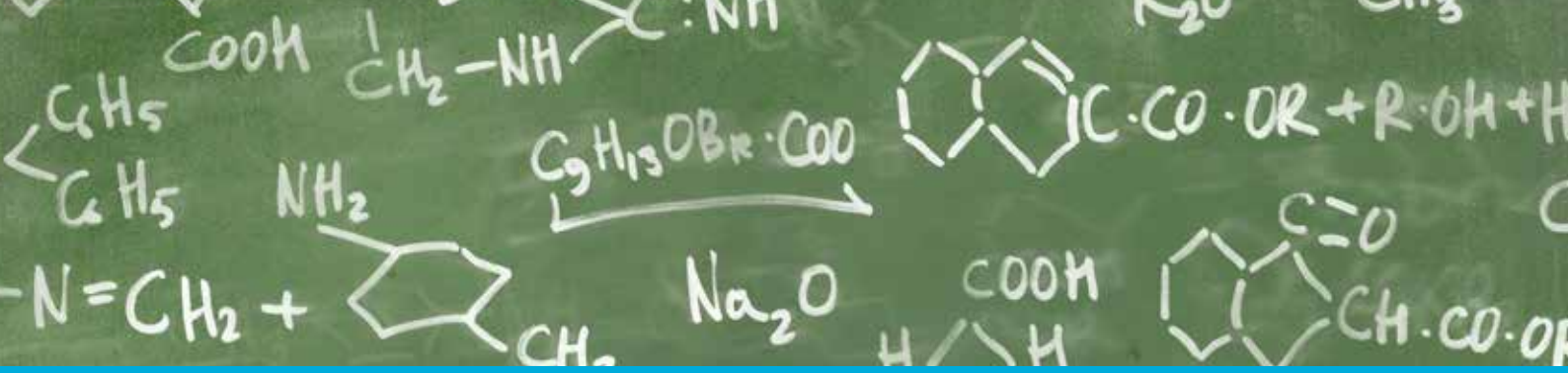

BASIC FORMULAS

H= Head(m)

Q = Flow(m³/h)

Capacity

$$l/sec \times 3.6 = m^3/h$$

$$m^3/h \div 3.6 = l/sec$$

$$Imp\ gpm \times 0.2271 = m^3/h \quad m^3/h \times 4.403 = Imp\ gpm$$

$$US\ gpm \div 0.246 = l/min \quad l/min \times 0.246 = US\ gpm$$

$$10000\ kg/hr = \frac{10m^3h}{Density(SG)}$$

Head/Pressure

$$Ft \div 3.28 = m$$

$$m \times 3.28048 = Ft$$

$$Bar \times 100 = kpa$$

$$m \times 9.805 = kpa$$

$$kpa \times 0.102 = m$$

$$m \times 0.098 = Bar$$

$$Bar \times 10.19 = m$$

$$m \times 1.45 = psi$$

$$psi \times 6.895 = kpa$$

Power

$$hp \times 0.746 = kw$$

$$kw \times 1.340483 = hp$$

$$kw\ abs = \frac{Q \times H \times SG}{367 \times Eff(\%)}$$

$$kw = \frac{Amps \times Volts \times Power\ Factor \times 1.732}{1000}$$

$$RPM = \frac{Hz \times 120}{No\ of\ Poles}$$

$$Hz = \frac{RPM \times No\ Of\ Poles}{120}$$

$$Velocity\ m/sec = \frac{Q \times 353.63}{(Pipe\ Dia)^2}$$

Efficiency

$$EFF(\%) = \frac{Q \times H \times SG}{367 \times kw(abs)}$$

Eff = Pump Eff%

Density = SG

Temperature

$$Deg.C = (deg.F-32) \times 0.556$$

$$Deg.F = (1.8 \times deg.C) + 32$$

Peripheral Speed

$$Peripheral\ Speed(Impeller) = \frac{imp.dia.(mm) \times \pi \times N(Rpm)}{60 \times 1000}$$

Viscosity

vis Viscous Liquid

w Water

Given: Q_{vis} in m³/h kinematic viscosity v in mm²/s

H_{vis} in m p_{vis} in kg/dm³

$$Q_w = \frac{Q_{vis}}{CQ}$$

$$H_w = \frac{H_{vis}}{CH}$$

$$Q_w = C\% \times \%w$$

$$P_{vis} = \frac{Q_{vis} \times H_{vis} \times P_{vis}}{367 \times Eff(\%) \times vis}$$

Centrifugal and Axial Flow Pump Affinity Laws:

Speed changes & impeller diameter remains the same:

$$Q1/Q2 = N1/N2$$

$$H1/H2 = (N1/N2)^2$$

$$P1/P2 = (N1/N2)^3$$

Impeller diameter changes and speed remains the same:

$$Q1/Q2 = D1/D2$$

$$H1/H2 = (D1/D2)^2$$

$$P1/P2 = (D1/D2)^3$$



08600 RAPID

10 Girder Street • Isando • 1601
T: +27 11 573 7400 • **F:** +27 11 974 8757

www.rapidallweiler.co.za