

# ALLCHEM®

## CNH-B SERIES

### PN 16 Volute Centrifugal Pumps (depending on materials up to PN 25) according to EN 22858/ISO 2858 and EN ISO 5199

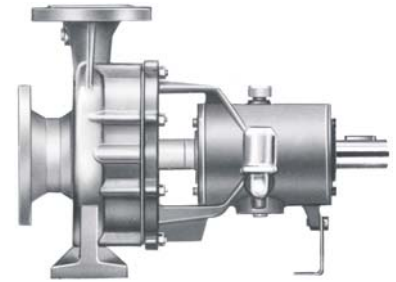

#### Utilization

Used to pump non-aggressive or aggressive liquids, cold or hot liquids, clean liquids, liquids containing solid particles, or viscous liquids. Used in the chemical or petrochemical industries, in power engineering, in process technology, environmental protection technology, wastewater engineering, marine engineering, offshore, and surface engineering.

#### Design and construction

Horizontal, single-stage, single-flow volute-casing centrifugal pump according to DIN EN 22858/ISO 2858. The pump also complies with the technical requirements of EN ISO 5199.

This pump series is constructed as a modular system in order to enable use of as many uniform structural components as possible. The pump reflects a process design type. The shaft bearing is provided in a bearing bracket.

#### Pump casing

The pump casing consists of a volute casing and casing cover. Some sizes have an additional intermediate ring.

With the exception of materials version W22, the casing parts can also be delivered with a heated jacket (welded into place).

#### Volute casing

Volute casing with cast feet. Depending on the temperature of the liquid, some pump sizes are available with centerline mounted feet arrangement.

The volute casings on some sizes are provided with a double volute in order to balance out radial forces.

#### Casing cover

Thanks to the modular system, the same casing cover is used for all of the pump sizes that are matched to a particular bearing bracket.

In order to better remove the mechanical seal's frictional heat, the seal chamber is conical in shape and wide open. The mechanical seal is directly integrated into the casing cover without an additional sealing cover.

#### Wear rings

If desired, the volute casing and casing cover can be delivered with optional exchangeable wear rings.

#### Impeller

Closed radial impeller with throttle gap on the front and rear sides. Axial thrust compensation provided by relief bores. Impellers available with exchangeable wear rings upon request. The impellers are balanced according to DIN ISO 1940 (Mechanical vibration - Balance quality requirements for rotors in a constant (rigid) state) balance quality G 6,3.

#### Shaft

The pump is equipped with a particularly torsion-proof shaft. The torsion-proofness and short distance between the pump-side bearing and shaft sealing achieves a truth of running that creates optimal conditions for shaft sealing. Deflection in the area of the shaft sealing is below the maximum permissible loads of 0.05 mm.

With the two-sided sealing of the shaft sleeve and a sealed impeller nut, the shaft is fully protected against contact with the liquid ("dry shaft").

A key transfers torque to the impeller.

#### Shaft sleeve

A shaft sleeve is provided as standard equipment.

Optionally, ceramic coating in the area of the shaft seal can protect the shaft sleeve from wear.

#### Bearing bracket

Thanks to the modular system, only four bearing bracket sizes are used for all pump sizes.

The pump's process design type enables disassembly of the bearing bracket, including impeller, casing cover, and shaft seal, without having to remove the volute casing from the pipe. Similarly, the motor must not be disassembled when using a spacer coupling.

#### Bearing

The shaft bearing exhibits oversized antifriction bearings that are designed for a nominal service life of at least 25,000 operational hours, even when used under the most difficult conditions.

If extended bearing service life is required, a reinforced bearing can be provided upon request.

#### Lubrication

The bearing is equipped with standard permanently lubricated groove ball bearings.

With the alternative oil-lubricated bearing, high-quality alloyed mineral oil according to DIN 51502-CL46 or ISO 3448-VG46 is recommended for lubrication purposes. Oil regulation is performed by a standard constant level oiler. Shaft sealing is provided by means of radial shaft seal rings. When liquid temperature is +200 °C or higher, the bearing bracket is equipped with an oil-cooling device.

**Performance data ①②**

Capacity	Q	up to	1200	m <sup>3</sup> /h
Delivery head	H	up to	147	m
Discharge pressure	p <sub>d</sub>	up to	25	bar ③
Liquid temperature	t	-100 up to	+350	°C
Nominal width of discharge branch	DN <sub>d</sub>	25 up to	250	mm
Power	P	up to	220	kW

- ① The performance data overview is based on drive speeds that occur when using three-phase motors in a 50-Hz power grid. Refer to the proposal and order confirmation for exact operation limits.
- ② The specified operation limits are maximum values that may have to be reduced in individual cases depending on technical variations. Refer to the respective order documentation for binding values.
- ③ Observe pressure/temperature limits specific to the material. Inlet pressure plus the maximum differential pressure generated by the impeller may not exceed the permissible working pressure.

**Minimum capacity**

Minimum capacity through the pump is required in order to protect it from overheating and elevated vibrational loads. Dimensional limit is calculated as follows for all sizes: Min. capacity: Q<sub>min.</sub> = 0.1 x Q<sub>opt.</sub>

**Viscosity**

During hydraulic selection, viscosities are considered with the corresponding conversion factors provided by Hydraulic Institute.

Viscous liquids can be efficiently pumped up to the following limits (based on the nominal width of the discharge branch):

Nominal width of discharge branch	< DN 50	up to	300	mm <sup>2</sup> /s
Nominal width of discharge branch	< DN 150	up to	500	mm <sup>2</sup> /s
Nominal width of discharge branch	> DN 150	up to	800	mm <sup>2</sup> /s

**Branch position and flanges**

Suction branch:	axial			
Discharge branch:	radial facing upward			
Flanges:	with materials			
	W20	W22	W23	W26 and W27
	DIN EN 1092-1/B1/PN 16	DIN EN 1092-2/B/PN 25	DIN EN 1092-1/B1/PN 25	DIN EN 1092-1/B1/PN 25

Other flange dimensions/designs are available as options.

**Shaft sealing**

The following mechanical seal designs according to DIN EN 12756 are available:

Design	Sizes on bearing bracket			
	45 und 45/1	60	70	75
Unbalanced single seal	KU 043	KU 053	KU 065	KU 070
Unbalanced single seal in tandem design	KU 043 + KU 043	KU 053 + KU 053	KU 065 + KU 065	KU 070 + KU 070
Balanced single seal	KB 043	KB 053	KB 065	KB 070
Balanced single seal in tandem design	KB 043 + KU 043	KB 053 + KU 053	KB 065 + KU 065	KB 070 + KU 070
Back-to-back, pump and atmosphere sides not balanced	UU 043	UU 053	UU 065	UU 070
Back-to-back, pump side not balanced, atmosphere side balanced	UB 043	UB 053	UB 065	UB 070
Back-to-back, pump and atmosphere sides balanced	BB 043	BB 053	BB 065	BB 070

Single mechanical seals can be equipped with a quench. The atmosphere-side is then sealed by a throttle bush or radial shaft seal ring.

Non-standardized seals (such as Cardridge designs) available upon request.

**Pressure and temperature limits, based on casing materials.**

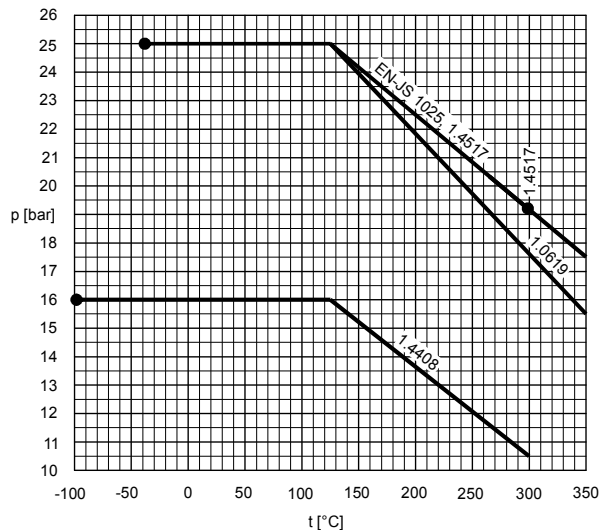

The provided pressure and temperature limits are maximum values that may be decreased depending on the design variation.

The base version can be used within the range of -30 to +160 °C. Outside this range, design measures will be needed.

**Heated casing parts**

Max. permissible pressure in heating chamber:	p =	20 bar
Max. permissible temp. in heating chamber:		
with wet steam	T =	210 °C
with heat transfer oil	T =	300 °C

**Quench, buffering, and flushing liquid**

Single mechanical seals can be and multiple mechanical seals in tandem arrangement must be equipped with a pressureless quench system.

Buffering fluid is needed with multiple mechanical seals in back-to-back arrangement in order to prevent escape of the pumped liquid and to lubricate the atmosphere-side seals. The pressure of the buffering fluid must be greater than the pressure of the pumped liquid.

The required amount of buffering fluid is 0.1 to 0.2 m³/h. The buffering fluid pressure should be about 1 bar over the pressure on the shaft seal.

The required buffering fluid pressure on the shaft seal is calculated as follows:

$$p_w = \frac{0,7 \times H_0 \times \rho}{10} \pm p_z + 1$$

- $p_w$  .....Buffering fluid pressure in [bar]
- $H_0$  ..... Pump delivery head at Q = 0 in [m]
- $\rho$  .....Density in [kg/dm³]
- $p_z$  .....Suction/inlet pressure in [bar]

Outside flushing liquid is utilized in order to prevent penetration of solids into the shaft seal when pumping abrasive liquids and liquids that tend for crystallize. It must be suitable for mixing with the liquid. The required amount of flushing liquid is 0.2 to 0.3 m³/h. The flushing liquid pressure should be about 1 bar over the pressure on the shaft seal.

**Explosion protection**



The pump fulfills the requirements according to EU explosion-protection directive 94/9/EC (ATEX 100a) for devices in device class II, category 2 G. Classification into temperature classes according to EN 13463-1 depends on the temperature of the pumped liquid. Refer to proposal and order documentation for the maximum permissible temperature of the liquid for the respective temperature classes.

**Note:** When operating the pump in category 2, suitable measures must be provided to prevent impermissible warming of the pump surfaces during disturbance.

**Materials**

Description	Materials				
	W20	W22	W23	W26	W27
Volute casing	1.4408	EN-JS 1025	1.0619	1.4517	1.4517
Casing cover	1.4408	EN-JS 1025	1.0619	1.4517	1.4517
Shaft	1.4021				
Impeller	1.4408	EN-JL 1030	EN-JL 1030	1.4408	1.4517
Bearing bracket	EN-JL 1040				

Other materials available upon request.

**Drive**

Standard with separately mounted standardized three-phase squirrel-cage motor on a shared base plate.

Other drive systems are possible.

Rated output of the drive machine must be specified according to DIN ISO 5199.

**Shaft coupling and coupling guard**

Drive torque is transferred through a flexible coupling to the pump shaft. At higher liquid temperatures a double cardan coupling must be used in order to balance out the heat expansion.

The shaft coupling can be delivered with or without a distance piece. The length of the distance piece is selected so that there is adequate axial tolerance to dismantle the insert unit.

A coupling guard with safety guarding according to DIN EN 294 is included whenever pump, base plate, and shaft coupling are delivered together.

**Base plate**

The pump unit is equipped with a U-plate as standard equipment. Optionally, a cast iron (steel with some sizes) base plate according to DIN 24259, EN 23661 or ISO 3661 can be provided.

**Model code**

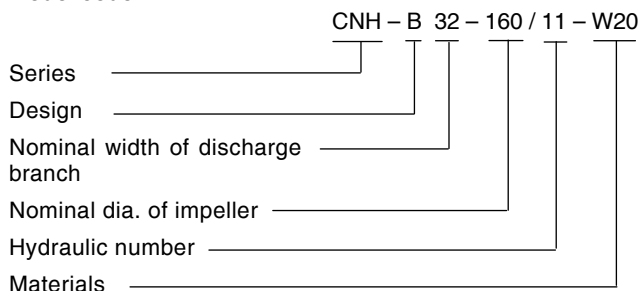

ATTENTION: Sizes 65-160 and 80-160 also available in short design type with bearing bracket 45 as 65-160k and 80-160k (price benefit, only casing dimensions according to DIN EN 22858/ISO 2858).

**Interchangeability of spare parts**

Teile-Nummer		161.01	183.01	210.01	321.01	321.02	330.01	433.01	433.02	452.01	454.01	456.01	458.01	461.01	471.01	509.01	524.01	922.01	
Bearing bracket size	Pump size	Casing cover	Support foot	Shaft	Groove ball bearing	Groove ball bearing	Bearing bracket	Mech. seal	Mech. seal	Gland	Stuffing box ring	Neck bush	Lantern ring	Gland packing	Sealing cover	Interm. ring	Shaft sleeve	Impeller nut	
45	25-160		1																
	32-160		1																
	40-160		1																
	50-160		2																
	25-200	1	2	1	1	1	1	1	1	1	1	1	1	1	1	-	1	1	
	32-200		2																
	40-200		2																
	50-200		2																
65-80-		2																	
80-		3																	
45/1	65-160	1	2	2	1	1	2	1	1	1	1	1	1	1	1	-	1	1	
	80-160		3																
60	65-200		4													-			
	80-200		4													-			
	100-		5													-			
	32-250		4													-			
	40-250	2	4	3	2	2	3	2	2	2	2	2	2	2	2	-	2	2	
	50-250		4													-			
	65-250		5													-			
	80-250		6													-			
40-315		5													1				
50-315		6													1				
70	100-	3	7													-			
	125-	3	8													-			
	150-	3	9													-			
	200-	3	10													-			
	65-315	4	7													-			
	80-315	4	8	4	3	3	4	3	3	3	3	3	3	3	3	-	3	3	
	100-	4	8													-			
	125-	4	9													-			
80-400	4	9													2				
100-	4	9													2				
125-	4	11													2				
75	150-		12													-			
	200-		13													-			
	250-		14													-			
	150-	5	12	5	4	4	5	4	4	3	3	4	3	3	4	-	4	4	
	200-		13													-			
	250-		14													-			
150-		15													-				
200-		16													3				

**Spare parts**

Recommended spare parts (initial need) according to DIN 24296, assuming two-year continuous operation.

Part No.	Spare parts	Number of pumps <sup>2)</sup> (including reserve pumps)						
		2	3	4	5	6 or 7	8 or 9	10 or more
		Spare parts quantity						
230	Impeller <sup>1)</sup>	1	1	1	2	2	2	20 %
502	Wear ring	2	2	2	3	3	4	50 %
503	Impeller wear ring	2	2	2	3	3	4	50 %
210, 922, 940	Shaft with keys and impeller nut <sup>1)</sup>	1	1	1	2	2	2	20 %
321, 323	Antifriction bearing	1	1	2	2	2	3	25 %
524	Shaft sleeve	2	2	2	3	3	4	50 %
456	Neck bush	1	1	2	2	2	3	30 %
461	Packing rings	4	4	6	6	6	8	100 %
433	Mechanical seal, complete <sup>1)</sup>	1	1	2	2	2	3	25 %
	Rotating ring <sup>1)</sup>	2	3	4	5	6	7	90 %
	Stationary ring <sup>1)</sup>	2	3	4	5	6	7	90 %
	Secondary seal at rotating ring <sup>1)</sup>	2	3	4	5	7	9	100 %
	Secondary seal at stationary ring <sup>1)</sup>	2	3	4	5	7	9	100 %
	Spring <sup>1)</sup>	1	1	1	1	2	2	20 %
400	Gaskets for pump casing	4	6	8	8	9	12	150 %
	Other gaskets	4	6	8	8	9	10	100 %
	Coupling	1	1	2	2	3	4	30 %

1) Optional 2) When using common spare parts for several different pumps in one system, the quantity of each spare part is based on the total number of pumps.

**Exchangeable**

Chemical standard pumps according to DIN EN 22858/ISO 2858

**Economical**

Modular system makes spare parts stocks economical.

**Modular**

Convertible to hermetically sealed mag drive

**Efficiency**

thanks to very good hydraulics

**Variable**

flange standards

**Versatile**

materials, seal, heating etc.

**Smooth running**

with pretensioned bearing

**Long service life**

thanks to robust bearing design with a bearing life of at least 25,000 operational hours

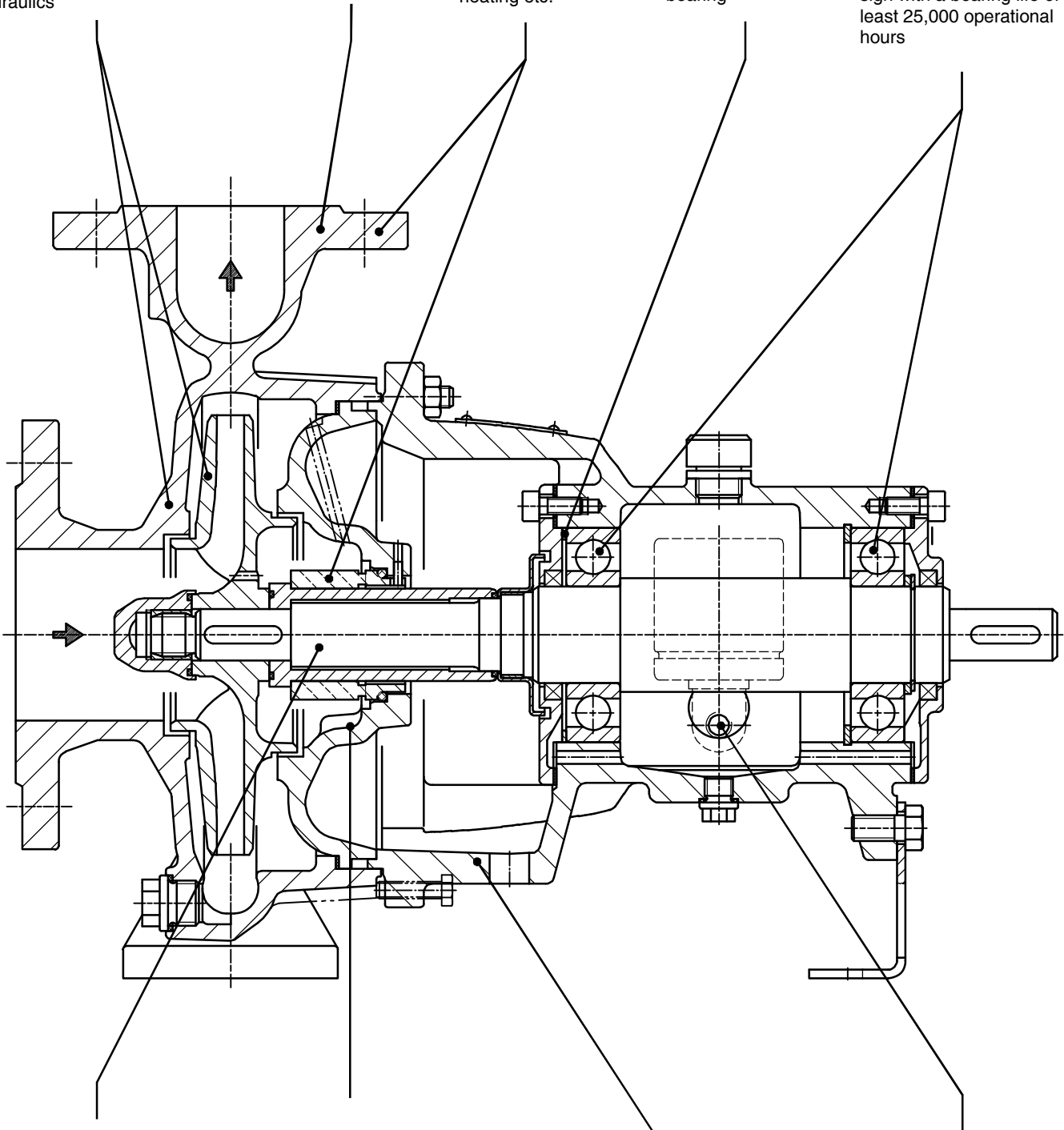

**Confident**

with an uncompromising torsion-proof shaft system for incredibly reliable shaft sealing.

**Safe in operation**

through optimized environmental conditions for the mechanical seal. Constant removal of heat, solids, and gases from the gasket.

**Easy to install**

with process design

**Maintenance-free**

with lifetime grease-lubricated groove ball bearings or easy-to-maintain oil lube versions with constant level oiler

Performance graphs – 50 Hz

n = 1450 1/min

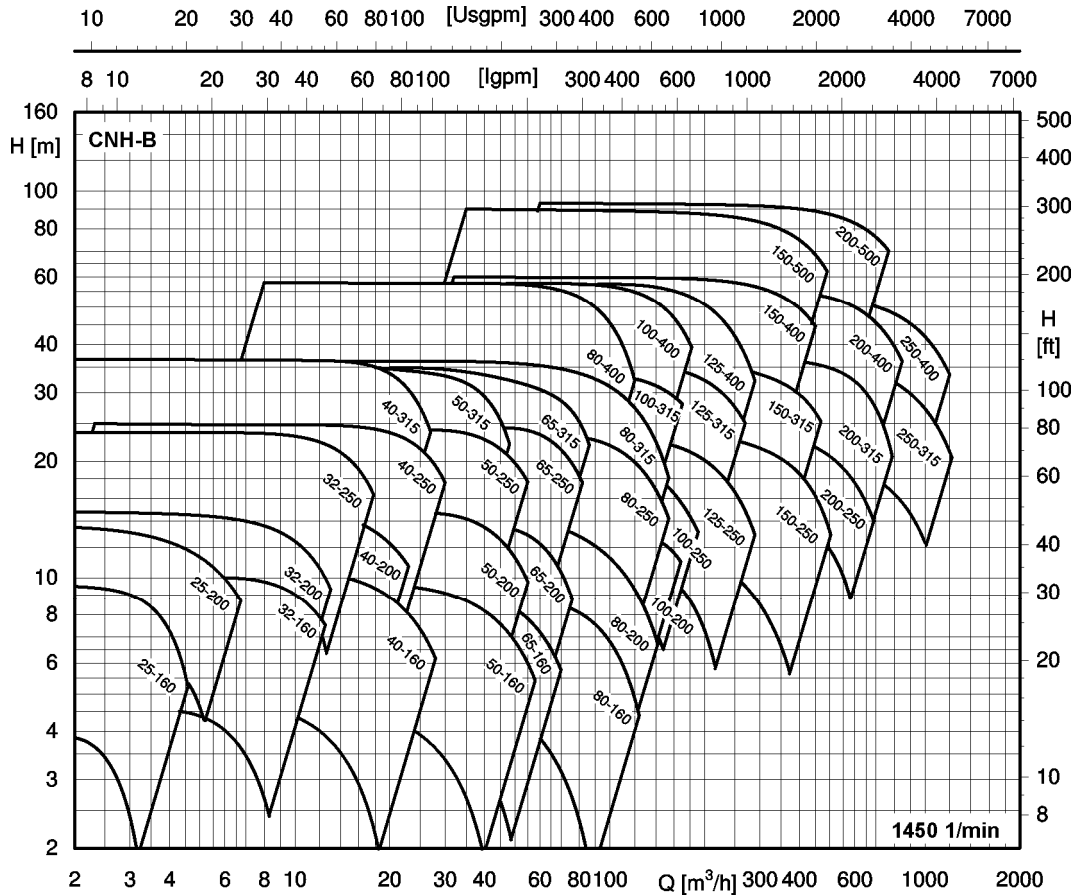

n = 2900 1/min

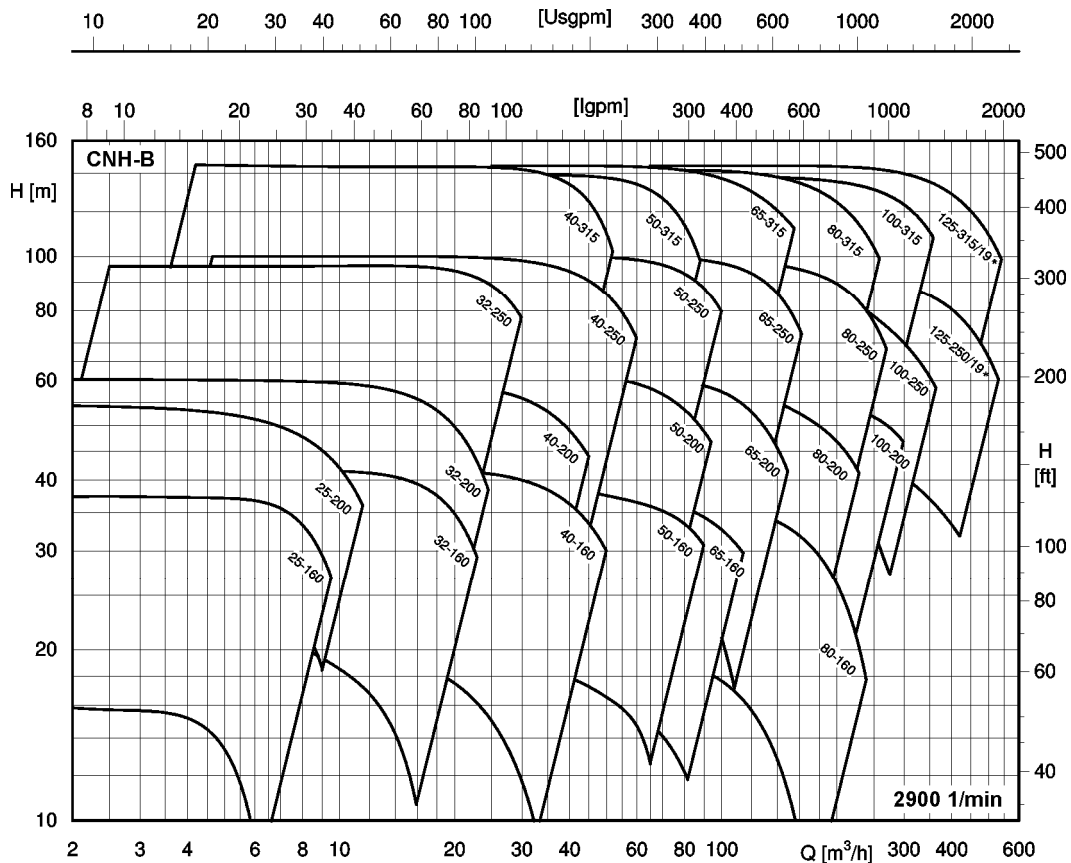

\* These sizes are not available in the W22 materials variation!

Performance graphs – 60 Hz

n = 1750 1/min

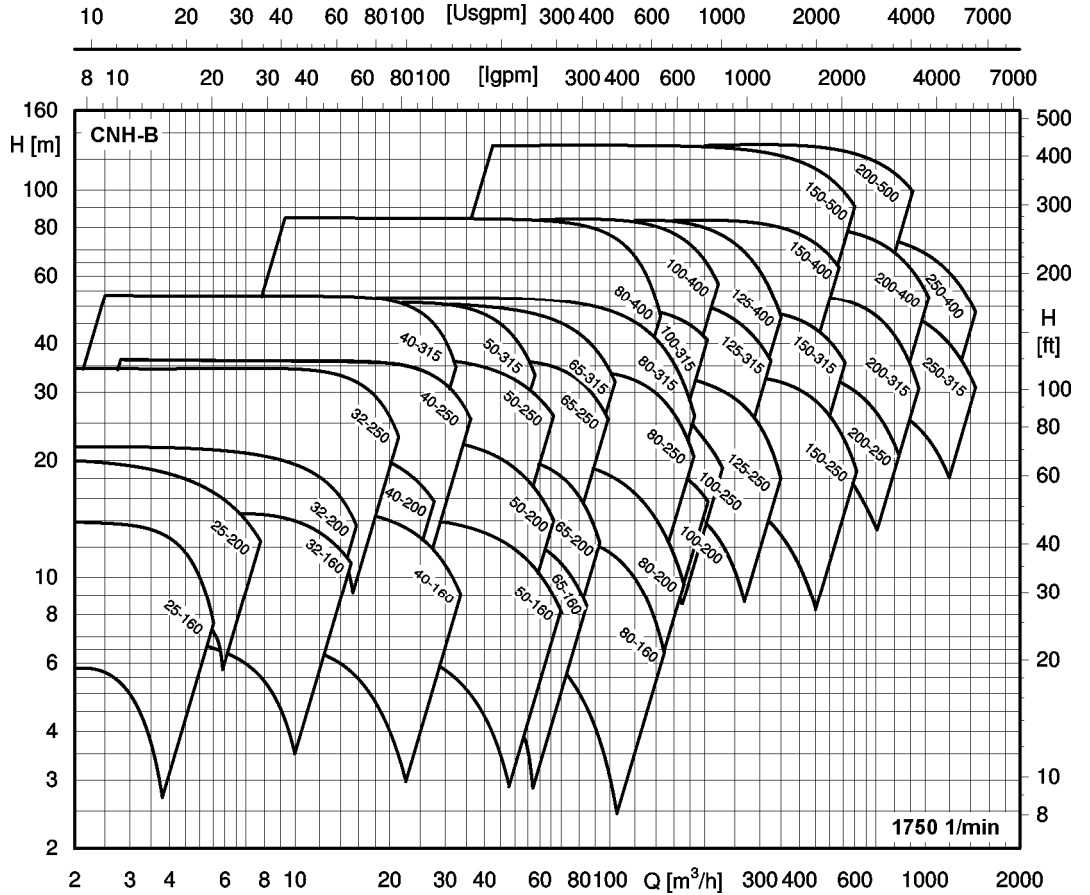

n = 3500 1/min

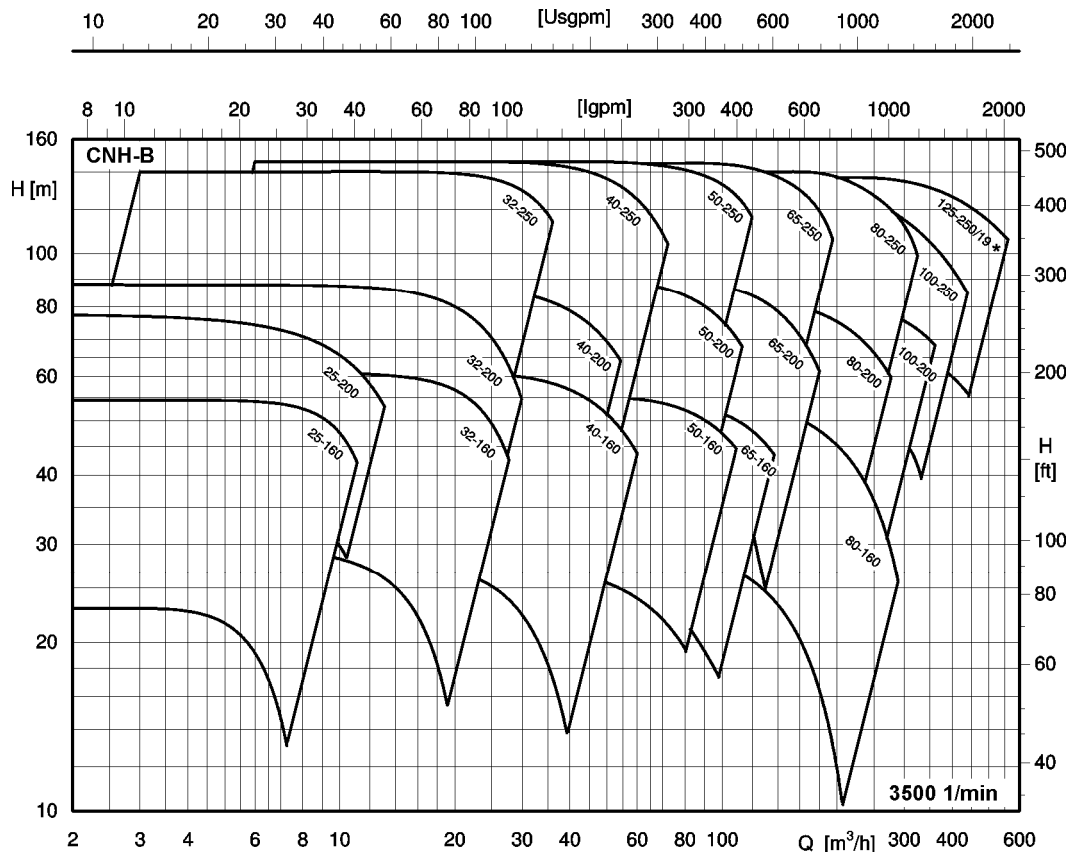

\* This size is not available in the W22 materials variation!



Sectional drawings

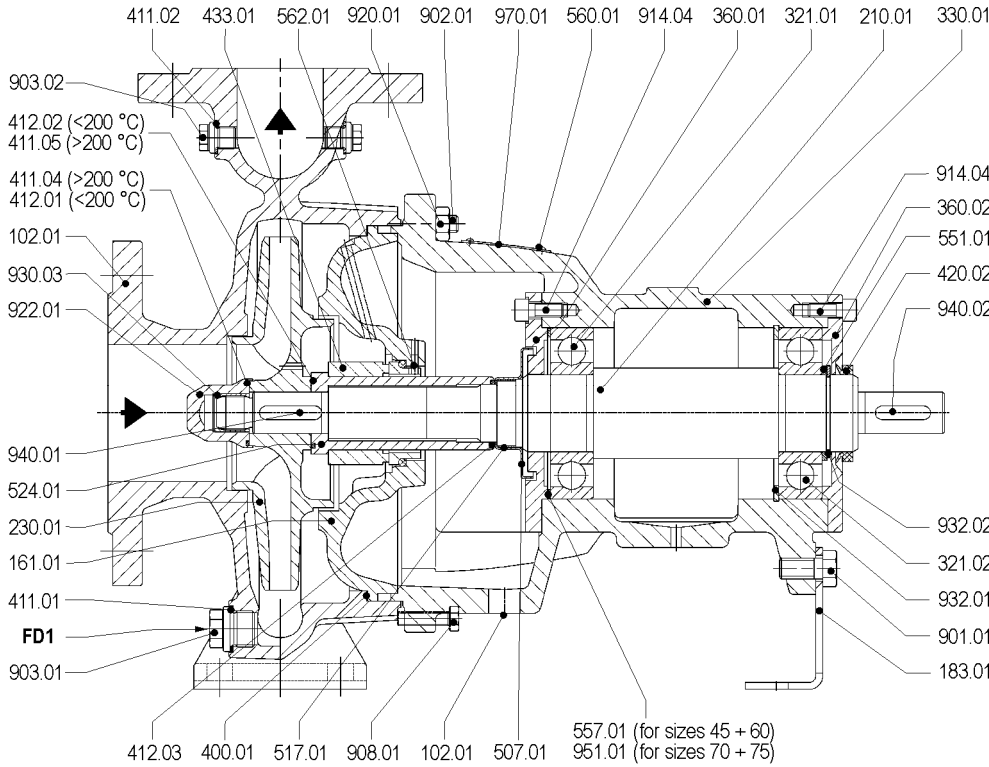

CNH-B with unbalanced single mechanical seal KU, with internal circulation, grease lubrication.

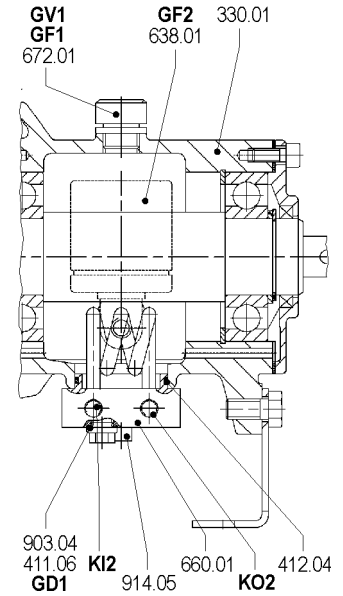

Version with bearing bracket cooling

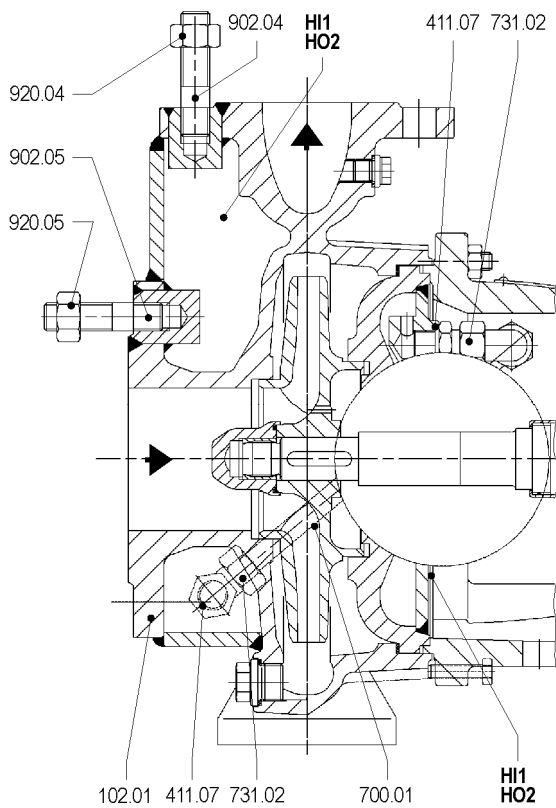

Version heated on both sides

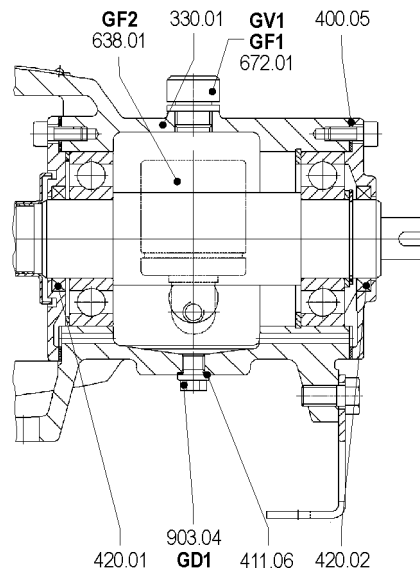

Version with oil lubrication

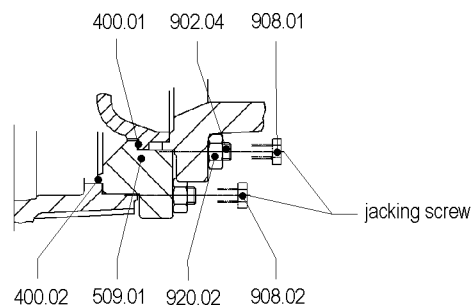

Version with intermediate ring



**Examples of shaft seal variations**

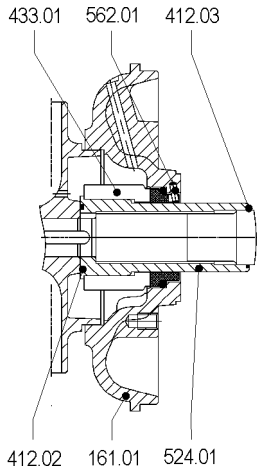

Balanced single mechanical seal

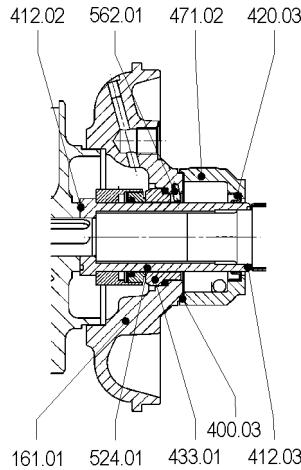

Unbalanced mechanical seal with quench and shaft seal ring

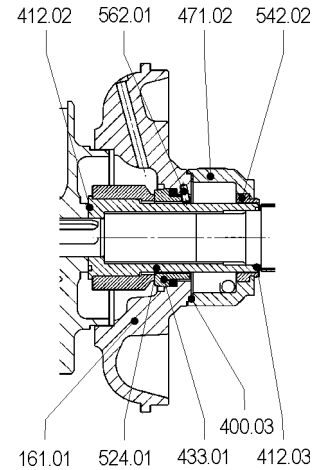

Balanced single mechanical seal with quench and throttle

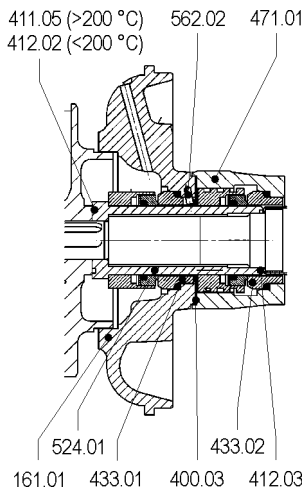

Unbalanced multiple mechanical seal in tandem arrangement

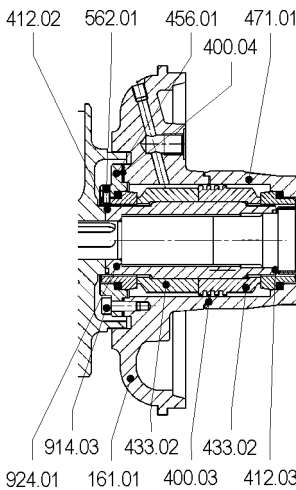

Balanced multiple mechanical seal in back-to-back arrangement

Description	Part No.
Volute casing	102.01
Casing cover	161.01
Support foot	183.01
Shaft	210.01
Impeller	230.01
Groove ball bearing	321.01
Groove ball bearing	321.02
Bearing bracket	330.01
Bearing cover	360.01
Bearing cover	360.02
Flange gasket	400.01
Flange gasket	400.02
Flange gasket	400.03
Flange gasket	400.04
Flange gasket	400.05
Seal ring	411.01
Seal ring	411.02
Seal ring	411.04
Seal ring	411.05
Seal ring	411.06
Seal ring	411.07

Description	Part No.
O-ring	412.01
O-ring	412.02
O-ring	412.03
O-ring	412.04
Shaft seal ring	420.01
Shaft seal ring	420.02
Shaft seal ring	420.03
Mechanical seal	433.01
Mechanical seal	433.02
Neck bush	456.01
Sealing cover	471.01
Sealing cover	471.02
Wear ring*	502.01
Wear ring*	502.02
Thrower	507.01
Intermediate ring	509.01
Flexible clamp ring	517.01
Shaft sleeve	524.01
Throttle bush	542.02
Supporting washer	551.01
Round head grooved pin	560.01

Description	Part No.
Ball bearing	
compensating disc	557.01
Cylindrical pin	562.01
Cylindrical pin	562.02
Constant level oiler	638.01
Cooling device	660.01
Venting	672.01
Pipe	700.01
Screwed connection	731.02
Hexagon screw	901.01
Stud bolt	902.01
Stud bolt	902.02
Stud bolt*	902.03
Stud bolt	902.04
Stud bolt	902.05
Screw plug	903.01
Screw plug	903.02
Screw plug	903.03
Screw plug	903.04
Jacking screw	908.01
Jacking screw	908.02
Cheese head screw	914.03
Cheese head screw	914.04
Cheese head screw	914.05
Cheese head screw	914.06
Hexagon nut	920.01
Hexagon nut	920.02
Hexagon nut*	920.03
Hexagon nut	920.04
Hexagon nut	920.05
Impeller nut	922.01
Circlip	932.01
Circlip	932.02
Locking insert	930.03
Key	940.01
Key	940.02
Cup spring	951.01
Rating plate	970.01

\* not shown

**Main dimensions and auxiliary connections**

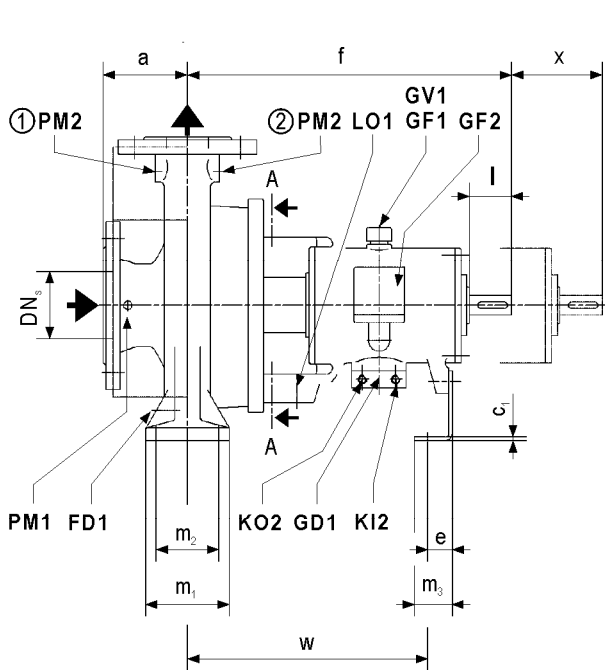

- ① Sizes at bearing bracket 45, 45/1 and 60 (optional)
- ② Sizes at bearing bracket 70 and 75 (optional)

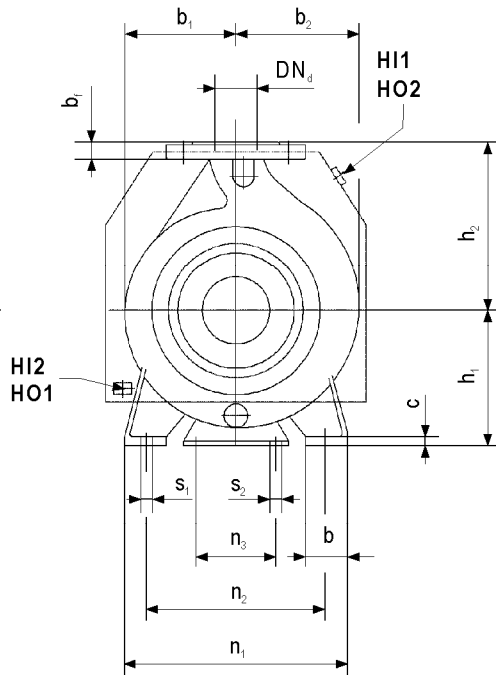

Sence of rotation: Clockwise, as seen from the driving side

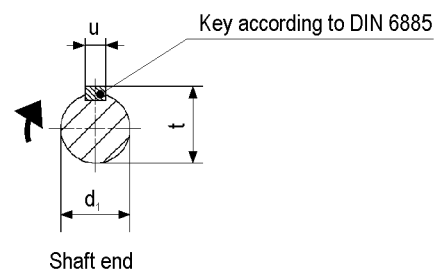
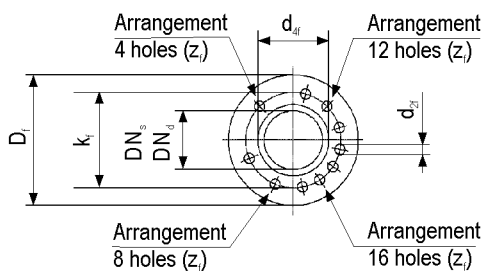
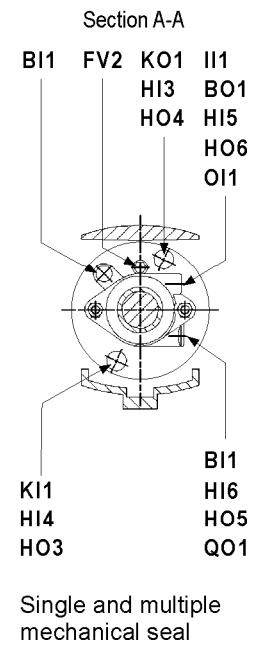

Flanges PN 16, DIN EN 1092-1						
DN <sub>s</sub> /DN <sub>d</sub>	D <sub>f</sub>	b <sub>f</sub>	k <sub>f</sub>	d <sub>4f</sub>	Z <sub>f</sub>	d <sub>2f</sub>
25	115	18	85	68	4	14
32	140	18	100	78	4	18
40	150	18	110	88	4	18
50	165	18	125	102	4	18
65	185	18	145	122	4	18
80	200	20	160	138	8	18
100	220	20	180	158	8	18
125	250	22	210	188	8	18
150	285	22	240	212	8	22
200	340	24	295	268	12	22
250	405	26	355	320	12	26
300	460	28	410	378	12	26

Flanges PN 25, DIN EN 1092-2						
DN <sub>s</sub> /DN <sub>d</sub>	D <sub>f</sub>	b <sub>f</sub>	k <sub>f</sub>	d <sub>4f</sub>	Z <sub>f</sub>	d <sub>2f</sub>
25	115	18	85	65	4	14
32	140	20	100	76	4	19
40	150	20	110	84	4	19
50	165	22	125	99	4	19
65	185	24	145	118	8	19
80	200	26	160	132	8	19
100	235	28	190	156	8	23
125	270	30	220	184	8	28
150	300	34	250	211	8	28
200	360	34	310	274	12	28
250	425	36	370	330	12	31
300	485	40	430	389	16	31

Flanges PN 25, DIN EN 1092-1						
DN <sub>s</sub> /DN <sub>d</sub>	D <sub>f</sub>	b <sub>f</sub>	k <sub>f</sub>	d <sub>4f</sub>	Z <sub>f</sub>	d <sub>2f</sub>
25	115	18	85	68	4	14
32	140	18	100	78	4	18
40	150	18	110	88	4	18
50	165	20	125	102	4	18
65	185	22	145	122	8	18
80	200	24	160	138	8	18
100	235	24	190	162	8	22
125	270	26	220	188	8	26
150	300	28	250	218	8	26
200	360	30	310	278	12	26
250	425	32	370	335	12	30
300	485	34	430	395	16	30

Size	Pump dimensions								Foot dimensions												Dis- mant- ling dim. x	Shaft end				
	① ①								for screws													d <sub>1</sub>	l	t	u	
	DN <sub>s</sub>	DN <sub>d</sub>	a	f	b <sub>1</sub>	b <sub>2</sub>	h <sub>1</sub>	h <sub>2</sub>	b	c	C <sub>1</sub>	e	m <sub>1</sub>	m <sub>2</sub>	m <sub>3</sub>	n <sub>1</sub>	n <sub>2</sub>	n <sub>3</sub>	w	S <sub>1</sub>						S <sub>2</sub>
25-160/11	40	25	80	385	128	128	132	160	50	15	4	28	100	70	45	240	190	110	285	M12	M12	100	24	50	27	8
25-200/11	40	25	80	385	132	132	160	180	50	15	4	28	100	70	45	240	190	110	285	M12	M12	100	24	50	27	8
32-160/11	50	32	80	385	130	130	132	160	50	15	4	30	100	70	45	240	190	110	285	M12	M12	100	24	50	27	8
32-200/11	50	32	80	385	130	135	160	180	50	15	4	30	100	70	45	240	190	110	285	M12	M12	100	24	50	27	8
32-250/11	50	32	100	500	170	170	180	225	65	15	6	24	125	95	40	320	250	110	370	M12	M12	100	32	80	35	10
40-160/11	65	40	80	385	130	130	132	160	50	15	4	30	100	70	45	240	190	110	285	M12	M12	100	24	50	27	8
40-200/11	65	40	100	385	130	140	160	180	50	15	4	30	100	70	45	265	212	110	285	M12	M12	100	24	50	27	8
40-250/11	65	40	100	500	170	170	180	225	65	15	6	24	125	95	40	320	250	110	370	M12	M12	100	32	80	35	10
40-315/11	65	40	125	500	200	200	200	250	65	20	6	24	125	95	40	345	280	110	370	M12	M12	100	32	80	35	10
50-160/11	80	50	100	385	130	130	160	180	50	15	4	30	100	70	45	265	212	110	285	M12	M12	100	24	50	27	8
50-200/11	80	50	100	385	135	150	160	200	50	15	4	30	100	70	45	265	212	110	285	M12	M12	100	24	50	27	8
50-250/11	80	50	125	500	170	170	180	225	65	15	6	24	125	95	40	320	250	110	370	M12	M12	100	32	80	35	10
50-315/11	80	50	125	500	200	200	225	280	65	20	6	24	125	95	40	345	280	110	370	M12	M12	100	32	80	35	10
65-160/11	100	65	100	500	130	155	160	200	65	15	4	30	125	95	45	280	212	110	370	M12	M12	100	32	80	35	10
65-160k/11	100	65	100	385	130	155	160	200	65	15	4	30	125	95	45	280	212	110	285	M12	M12	100	24	50	27	8
65-200/11	100	65	100	500	170	170	180	225	65	15	6	24	125	95	40	320	250	110	370	M12	M12	140	32	80	35	10
65-250/11	100	65	125	500	170	190	200	250	80	18	6	24	160	120	40	360	280	110	370	M16	M12	140	32	80	35	10
65-315/11	100	65	125	530	200	230	225	280	80	20	6	31	160	120	56	400	315	110	370	M16	M12	140	42	110	45	12
80-160/11	125	80	125	500	145	180	180	225	65	15	4	30	125	95	45	320	250	110	370	M12	M12	100	32	80	35	10
80-160k/11	125	80	125	385	145	180	180	225	65	15	4	30	125	95	45	320	250	110	285	M12	M12	100	24	50	27	8
80-200/11	125	80	125	500	170	190	180	250	65	18	6	24	125	95	40	345	280	110	370	M12	M12	140	32	80	35	10
80-250/11	125	80	125	500	185	210	225	280	80	18	6	24	160	120	40	400	315	110	370	M16	M12	140	32	80	35	10
80-315/11	125	80	125	530	210	255	250	315	80	20	6	31	160	120	56	400	315	110	370	M16	M12	140	42	110	45	12
80-400/11	125	80	125	530	245	260	280	355	80	20	6	31	160	120	56	435	355	110	370	M16	M12	140	42	110	45	12
100-200/11	125	100	125	500	170	205	200	280	80	18	6	24	160	120	40	360	280	110	370	M16	M12	140	32	80	35	10
100-250/11	125	100	140	530	200	230	225	280	80	20	6	31	160	120	56	400	315	110	370	M16	M12	140	42	110	45	12
100-315/11	125	100	140	530	210	260	250	315	80	20	6	31	160	120	56	400	315	110	370	M16	M12	140	42	110	45	12
100-400/11	125	100	140	530	250	295	280	355	100	20	6	31	200	150	56	500	400	110	370	M20	M12	140	42	110	45	12
125-250/11	150	125	140	530	210	260	250	355	80	20	6	31	160	120	56	400	315	110	370	M16	M12	140	42	110	45	12
125-250/19	150	125	140	530	210	260	250	355	80	20	6	31	160	120	56	400	315	110	370	M16	M12	140	42	110	45	12
125-315/11	150	125	140	530	215	255	280	355	100	20	6	31	200	150	56	500	400	110	370	M20	M12	140	42	110	45	12
125-315/19	150	125	140	530	215	255	280	355	100	20	6	31	200	150	56	500	400	110	370	M20	M12	140	42	110	45	12
125-400/11	150	125	140	530	265	320	315	400	100	20	6	31	200	150	56	500	400	110	370	M20	M12	140	42	110	45	12
150-250/11	200	150	160	530	225	285	280	375	100	20	6	31	200	150	56	500	400	110	370	M20	M12	180	42	110	45	12
150-315/11	200	150	160	670	265	280	315	400	100	22	8	33	200	150	58	550	450	140	500	M20	M16	180	48	110	51,5	14
150-400/11	200	150	160	670	300	330	315	450	100	22	8	33	200	150	58	550	450	140	500	M20	M16	180	48	110	51,5	14
150-500/11	200	150	180	670	320	380	375	500	100	25	8	33	200	150	58	550	450	140	500	M20	M16	180	60	110	51,5	14
200-250/11	200	200	180	530	265	340	355	425	100	27	6	31	200	150	56	550	450	110	370	M20	M12	180	42	110	45	12
200-315/11	250	200	200	670	275	350	355	450	100	27	8	33	200	150	58	550	450	140	500	M20	M16	180	48	110	51,5	14
200-400/11	250	200	180	670	315	370	355	500	100	30	8	33	200	150	58	550	450	140	500	M20	M16	180	60	110	51,5	14
200-500/11	250	200	200	670	360	440	425	560	100	25	8	33	200	150	58	660	560	140	500	M20	M16	180	60	110	51,5	14
250-315/11	300	250	250	670	315	445	400	560	130	30	8	33	260	190	58	690	560	140	500	M24	M16	180	48	110	51,5	14
250-400/11	300	250	225	670	350	440	375	625	120	30	8	33	280	200	58	630	500	140	500	M27	M16	180	60	110	51,5	14

① not applicable to heated version

**Auxiliary connections**

Connections	Size	Description
BI1	G 1/4	Shaft seal – sealing inlet
BO1	G 1/4	Shaft seal – sealing outlet
FD1	G 1/2	Volute casing – product draining
FV2	G 1/4	Seal chamber – product venting
GD1	G 1/4	Bearing bracket – lubrication draining
GF1	G 1/2	Bearing bracket (venting) – lubrication filling
GF2	G 1/4	Bearing bracket (constant level oiler) – lubrication filling
GV1	G 1/2	Bearing bracket – lubrication venting
HI1	G 3/8	Volute casing – heat steam inlet
HI2	G 3/8	Volute casing – heat liquid inlet
HI3	G 3/8	Casing cover – heat steam inlet
HI4	G 3/8	Casing cover– heat liquid inlet
HI5	G 1/4	Sealing cover– heat steam inlet
HI6	G 1/4	Sealing cover– heat liquid inlet
HO1	G 3/8	Volute casing – heat steam outlet
HO2	G 3/8	Volute casing – heat liquid outlet
HO3	G 3/8	Casing cover – heat steam outlet
HO4	G 3/8	Casing cover – heat liquid outlet
HO5	G 1/4	Sealing cover– heat steam outlet
HO6	G 1/4	Sealing cover– heat liquid outlet
II1	G 1/4	Seal chamber – injection/flushing liquid inlet
KI1	G 3/8	Seal chamber – cooling inlet
KI2	G 1/4	Bearing bracket – cooling inlet
KO1	G 3/8	Seal chamber – cooling outlet
KO2	G 1/4	Bearing bracket – cooling outlet
LO1	G 1/2	Pump collection trough – leak outlet
PM1	G 1/4	Suction branch - pressure gauging
PM2	G 1/4	Discharge branch - pressure gauging
QI1	G 1/4	Seal chamber – quench inlet
QO1	G 1/4	Seal chamber – quench outlet

Subject to technical alterations.



ALLWEILER®

**ALLWEILER GmbH**  
 Postfach 1140 · 78301 Radolfzell  
 Allweilerstr. 1 · 78315 Radolfzell  
 Germany  
 Tel. +49 (0)7732 86-0  
 Fax. + 49 (0)7732 86-436  
 E-mail: [service@allweiler.de](mailto:service@allweiler.de)  
 Internet: <http://www.allweiler.com>

GB/12.2012 – Ident-No. 488059

The mentioned performance data and additionally all standard references are to be considered as a product and performance abstract only. The particular operating limits can be taken from the quotation or order acknowledgement.



Only those who perform research can create sustainable, innovation-based benefits. The German Stifterverband für die Deutsche Wissenschaft has awarded Allweiler GmbH its "Innovation Through Research" certificate for its commitment to research.