

Volute casing pumps

SIHI^{SuperNova}



Type ZLKD 32 - 125 ... 200 - 250

TECHNICAL DATA

Output:	max. 740 m ³ /h		
Head:	max. 90 m		
Speed:	max. 3600 rpm		
Material:	grey cast iron: 0B, 0C, 0E stainless steel: 4B		
Temperature:	max. 120 °C		
Casing pressure:	material design	4B	PN 16
		0B, 0C, 0E	PN
16/10 ¹⁾			
Shaft seal:	standard mechanical seal		
Flange connections:	material design		
	4B	DIN 2501 PN 16	
	0B, 0C, 0E	DIN 2501 PN 16/10 ¹⁾	
Direction of rotation:	clockwise, when looking at the pump from the drive end		

APPLICATION

Volute casing pumps of the ZLK range (meeting DIN 24255 / EN 733 and ISO 9908) are used when clear or turbid liquids free from solid particles are to be pumped. Application areas for pumps in this range include:

- Automobile, mechanical and general engineering industries
- Food and beverage industry
- Pharmaceutical industry
- Paint industry
- Plastics and rubber industry
- Iron and non-ferrous metal industry
- Paper and pulp industry
- Textile industry
- Building and construction industry
- Heating and air conditioning
- Drainage
- Water supply
- Irrigation

DESIGN

Single-stage volute casing pumps with connections and nominal performances according to DIN 24255 / EN 733, plus 6 additional sizes.

The design of the pump allows the complete drive unit to be withdrawn from the casing without disturbing the attached pipe work.

The close coupled design, also, allows dismantling or replacing the motor without disturbing the pump.

There is no common shaft for pump and motor, standard motors can be used.

The set is a space saving easy to install pump unit.

The range covers 34 sizes.

¹⁾ from 100160 to 200250 10 bar

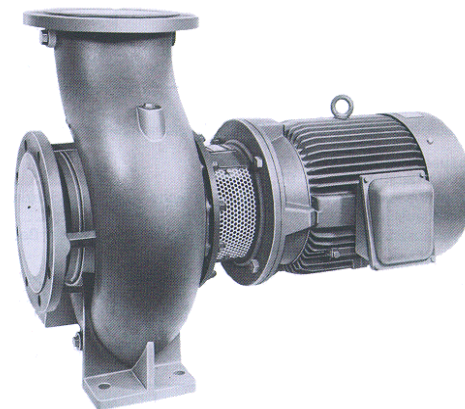

CONSTRUCTION

Casing pressure:

Material 4B:	max. 16 bar from -40 °C to 120 °C
Material 0B, 0C, 0E:	max. 16/10 ¹⁾ bar from -20 °C to 120 °C

Max. casing pressure = inlet pressure plus delivery head at zero flow

Please note: The relevant technical regulations and safety rules must be observed.

Flanges location:

Axial suction flange, discharge flange radially upwards.

Flanges:

Material 4B:	Correspond to DIN EN 1092-1/PN16.
Material 0B, 0C, 0E :	Correspond to DIN EN 1092-2/PN 16/10 ¹⁾ .

Flanges drilled according to ANSI 150 can be supplied.

Hydraulic:

Frist Hydraulic:	Design code A
Second Hydraulic:	Design code B

Bearing:

Bearing bracket equipped with one ball bearing lifetime greased according to DIN 625.

Volute casing with feet, n = 1450 rpm. code: 3

Volute casing without feet, n = 2900 rpm. code: 4

Shaft sealing:

The shaft is sealed by means of a single mechanical seal, flushed from internal source.

Code BH3: Unbalanced bellows mechanical seal, seal face materials SiC/carbon, elastomer EPDM

Code BHS: Unbalanced bellows mechanical seal, seal face materials SiC/SiC, elastomer FPM (Viton)

Code BHJ: Unbalanced bellows mechanical seal, seal face materials SiC/carbon, elastomer FPM (Viton)

Material design:

Pos.	Component	Material						Material code			
		EN number	EN denomination	DIN number	DIN denomination	US denomination		0B	0C	0E	4B
						ASTM Standard	AISI				
10.20	Volute casing	EN-JL 1040	EN-GJL 250	0.6025	GG-25	A 278 Class 30		x	x	x	
		1.4408	GX5CrNiMo19-11-2	1.4408	G-X5CrNiMoNb 18 10	A 351 CF8M	316				x
16.10	Casing cover	EN-JL 1040	EN-GJL 250	0.6025	GG-25	A 278 Class 30		x	x	x	
		1.4408	GX5CrNiMo19-11-2	1.4408	G-X5CrNiMoNb 18 10	A 351 CF8M	316				x
21.00	Shaft	1.4021	X 20 Cr13	1.4021	X 20 Cr13	A 276 Type 420		420	x	x	x
		1.4401	X5CrNiMo17-12-2	1.4401	X5CrNiMo 17 12 2	A 167 Gr316	316				x
23.00	Impeller	EN-JL 1040	EN-GJL 250	0.6025	GG-25	A 278 Class 30		x			
		CC 480 K	CuSn10-Cu	2.1050	G-CuSn10	B 427 C91600			x		
		1.4408	GX5CrNiMo19-11-2	1.4408	G-X5CrNiMoNb 18 10	A 351 CF8M	316			x	x
34.00	Bearing bracket	GG-25						x	x	x	x
43.30	Mech. seal	SiC/carbon, SiC/SiC, elastomer EPDM or FPM (Viton)						x	x	x	x

Casing seal:

The casing is sealed by means of a confined flat gasket of EWP 210 material. Code of this design: 2.

The casing is sealed by means of a confined flat gasket of PTFE material. Code of this design: 4.

Drive/Speed:

Using commercial electric motors.

Type IM B5 for pumps with volute casing with feet, n = 1450 rpm. Code: 3

Type IM B35 for pumps with volute casing without feet, n = 2900 rpm. Code: 4

To determine the drive power we recommend the following safety margin:

Up to 4 kW: 25%

4 to 7,5 kW: 20%

above 7,5 kW: 15%

The following speeds must not be exceeded:

Size	max. speed rpm	Size	max. speed rpm	Size	max. speed rpm	Size	max. speed rpm
032125 50160	3600	032250	3000	040315 125200	1800	150250	1500
032160 50200		040250		050315 125250		200250	
032200 65125		050250		065315 150200			
040125 65160		065250		080250			
040160 65200 ¹⁾		100160		080315			
040200 80160 ¹⁾		100200		100250			
050125 80200 ¹⁾				100315			

¹⁾ in material design 4B max. speed 3000 rpm.

The max. speeds are derived from the permissible shaft load and from the permissible peripheral speed of the impellers.

Installation position:

In principle ZLK pumps can be installed either horizontally or vertically. If the piping system is sufficiently rigid, they can also be suspended and fastened in the pipeline. The fastening for code:3 is made at the feet of the volute casing n = 1450 rpm. and for code: 4 at the feet of the motor n = 2900 rpm.

Please note:

The arrangement of the motor below the pump is not admissible because of operating safety.

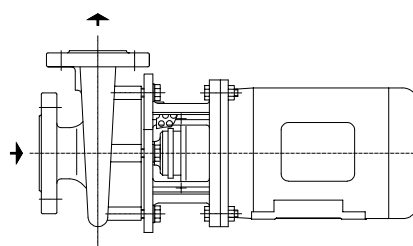

Horizontal installation

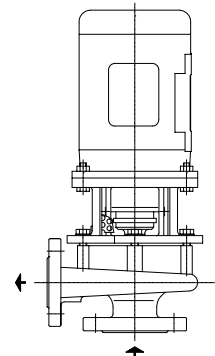

Vertical installation

General comments:

For horizontal pumps, large coupled, refer to our series ZLND and for INLINE pumps, close coupled, refer to our series ZLI.

For equipping hot media systems a complete programme is available for a flow range between 1-1000 m³/h consisting of the range:

- ZTN** volute pumps to EN 733 design with base plate, t_{max} 350 °C PN 16. Heat transfer oil.
- ZTK** volute pumps to EN 733 close coupled design, t_{max} 350 °C PN 16. Heat transfer oil.
- ZTI** volute pumps to EN 733 as INLINE construction, t_{max} 350 °C PN 16. Heat transfer oil.
- ZEN** volute pumps to EN 22858, t_{max} 230 °C PN 40. Hot water design.
- ZDN** volute pumps to EN 22858, t_{max} 207 °C PN 25. Hot water design.
- ZHN** volute pumps to EN 733, t_{max} 180 °C PN 16. Hot water design.
- ZLI** volute pumps to EN 733 as INLINE construction, t_{max} 150 °C PN 25. Hot water design.

Sectional drawing and nomenclature

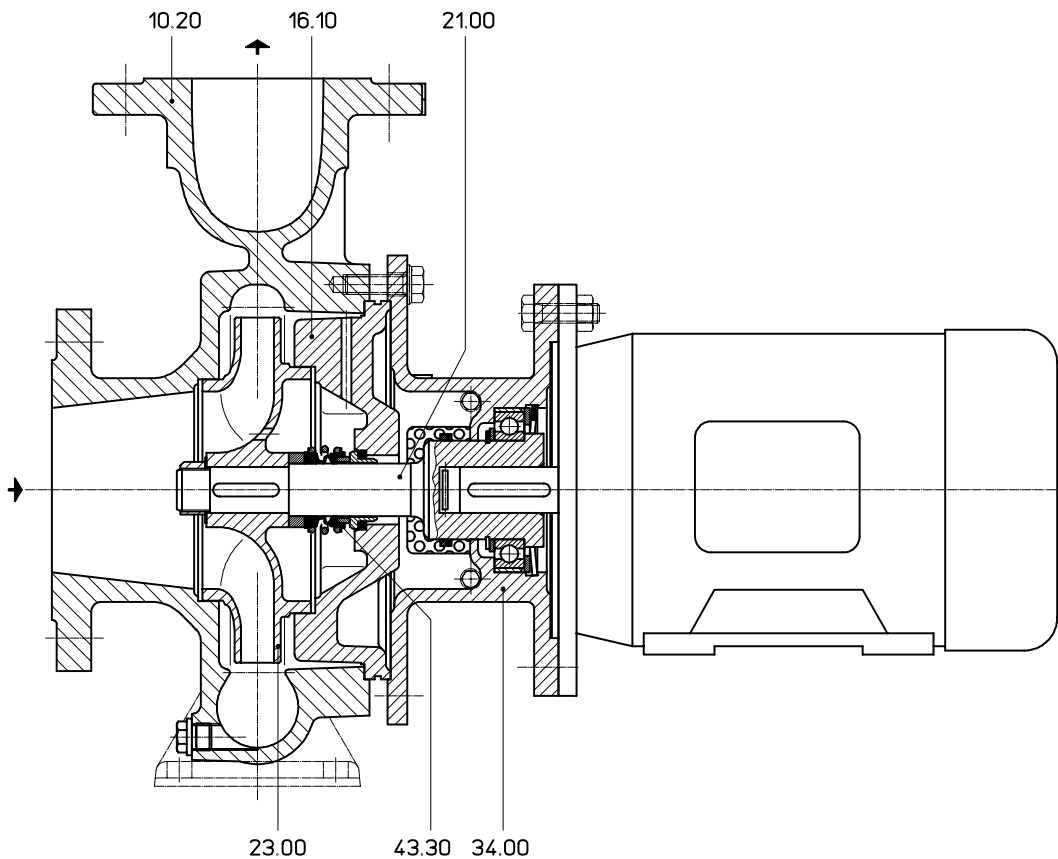

10.20	volute casing	21.00	shaft
16.10	casing cover	34.00	bearing bracket
23.00	impeller	43.30	mechanical seal BH3/BHS/BHJ

Package unit = pump casing + compact insert unit + standard motor *

The standard construction set consisting of volute casing, casing cover, impeller and mechanical seal. If this standard construction set is supplemented by a compact insert unit, you will get a package unit which is easy to combine.

The large-dimensioned bearing bracket in the insert unit relieves completely the standard motor from hydraulic axial loads and allows many motor combinations with the pumping unit.

The special advantage of the close coupled unit are lower installation and operating costs and a space saving of approx. 30 % with respect to the large coupled pump, which needs to be fitted together the motor through a flexible coupling in a common base plate unit.

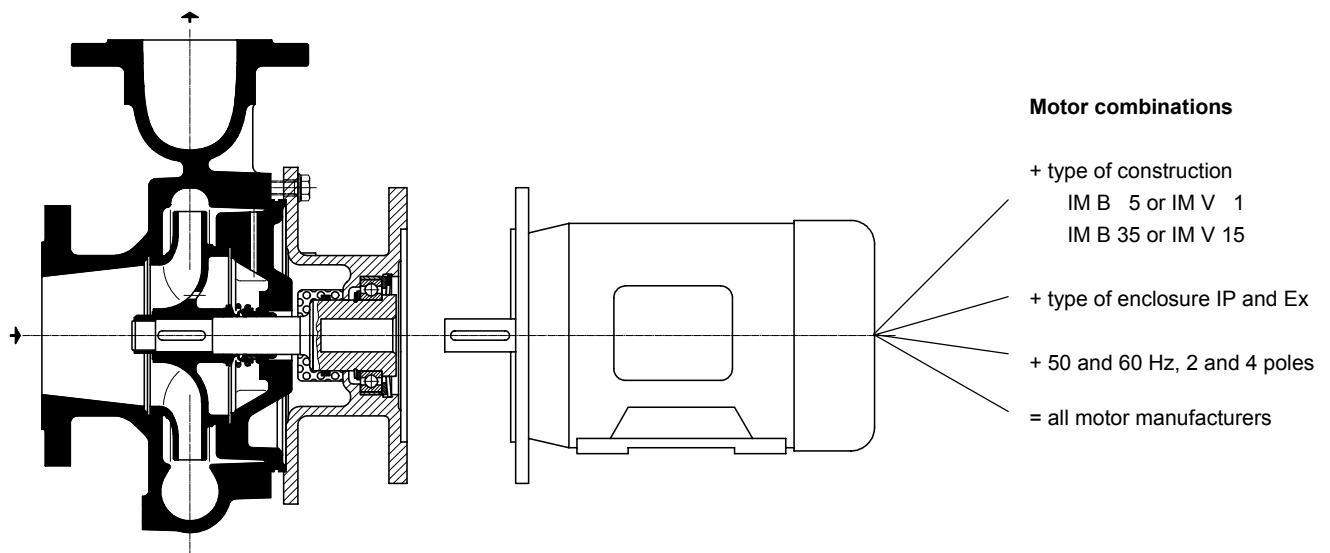

* shaft end to DIN 748 part 3
key to DIN 6885 sheet 1

Performance graph

n = 1450 rpm

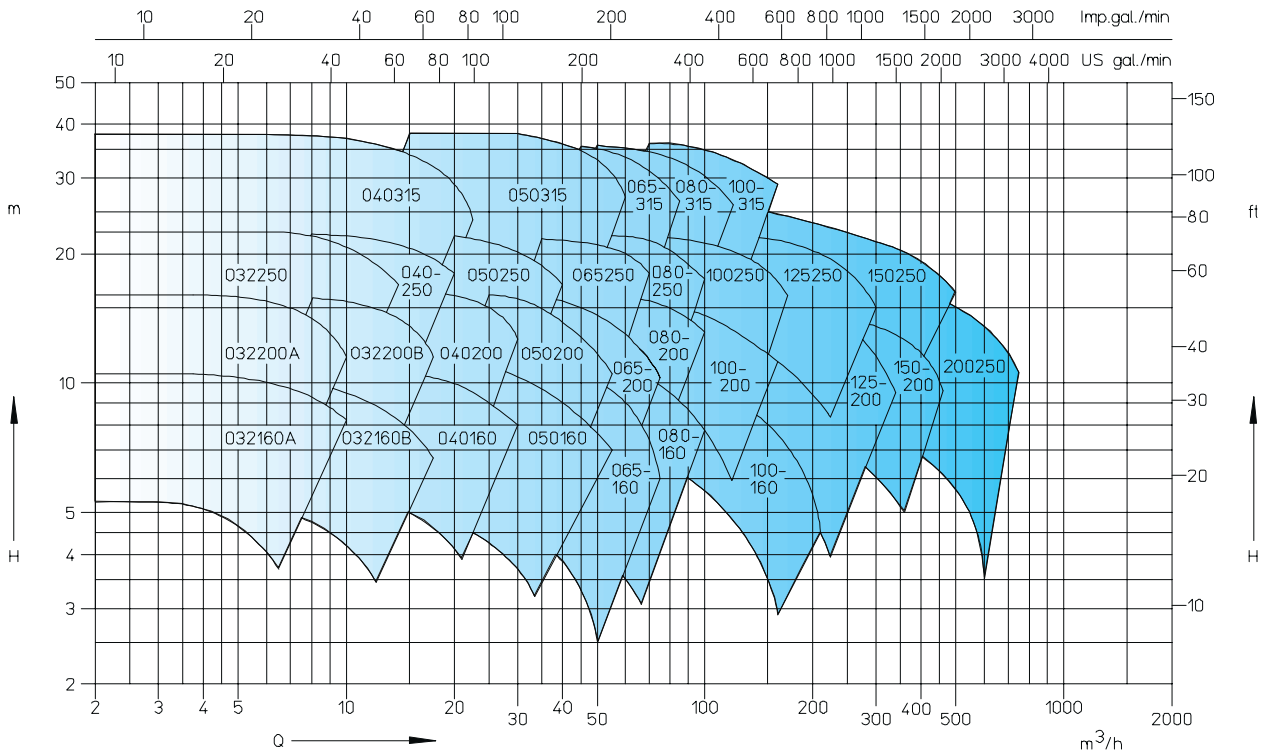

Performance graph

n = 2900 rpm

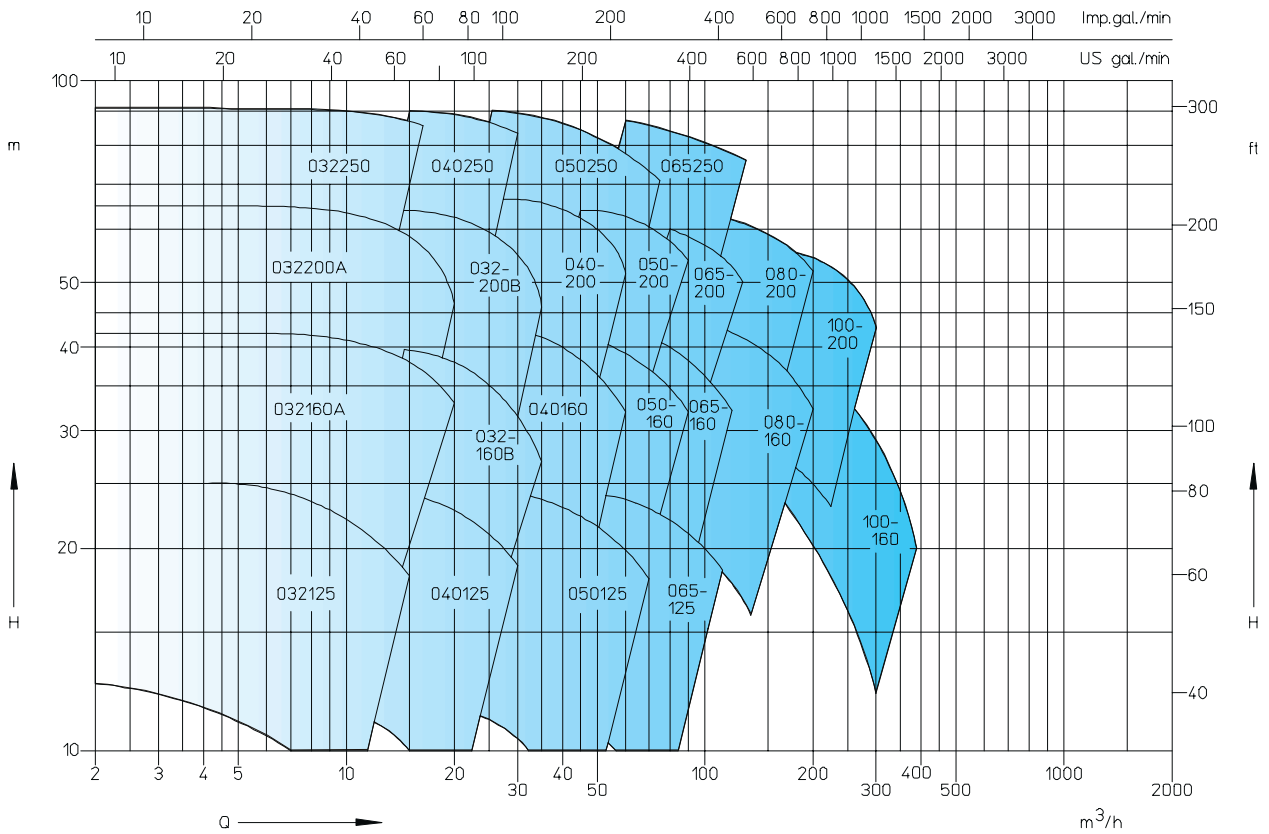

Dimension table

n = 1450 rpm

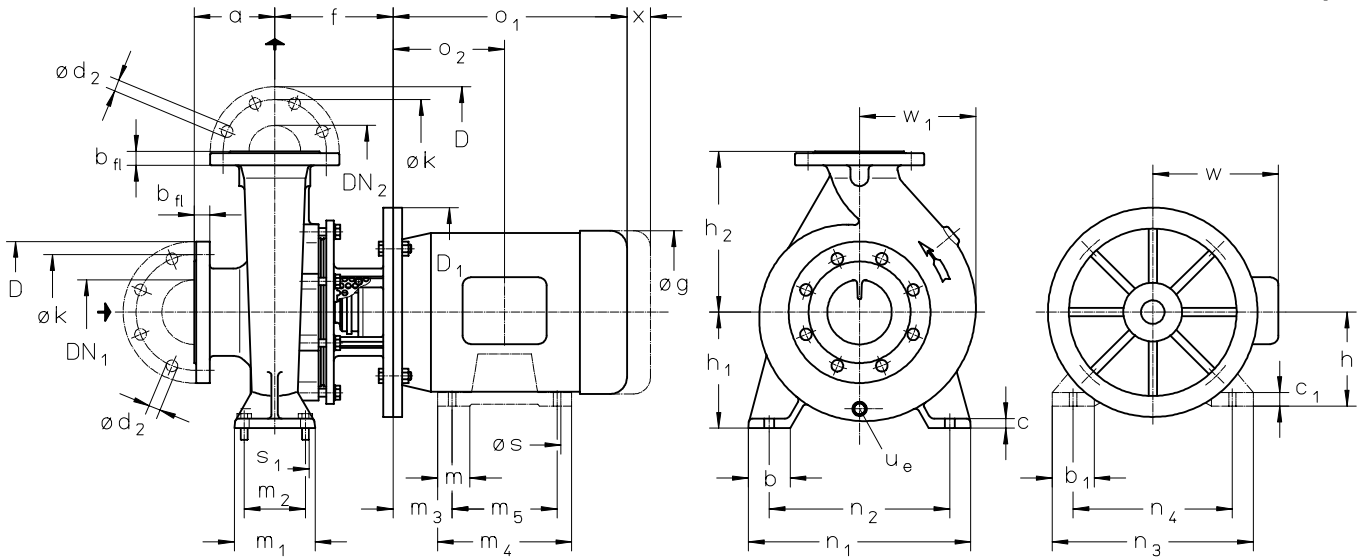

ue = drain connection G 1/4, from DN₂ 65 G 3/8

Dimensions in mm.

Size	Motor size n = 1450 rpm				DN ₂	DN ₁	a	b	c	f	h ₁	h ₂	m ₁	m ₂	n ₁	n ₂	s ₁	w ₁	x ²⁾	Pump weight kg		
	OB	OC, OE	4B																			
032160 A	080				32	50	80	50	15	168	132	160	100	70	240	190	M12	115	100	28	29	34
032160 B	080	090			32	50	80	50	15	168	132	160	100	70	240	190	M12	120	100	28	29	34
032200 A	080	090			32	50	80	50	15	168	160	180	100	70	240	190	M12	130	100	32	33	41
032200 B	080	090			32	50	80	50	15	168	160	180	100	70	240	190	M12	140	100	32	33	41
032250 ¹⁾	080	090	100		32	50	100	65	15	178	180	225	125	95	320	250	M12	160	100	42	44	52
040160	080	090			40	65	80	50	15	178	132	160	100	70	240	190	M12	130	100	32	34	36
040200	080	090	100		40	65	100	50	15	168	160	180	100	70	265	212	M12	145	100	44	45	47
040250	090	100			40	65	100	65	15	178	180	225	125	95	320	250	M12	160	100	49	51	52
040315 ¹⁾	100	112			40	65	125	65	18	194	225	250	125	95	345	280	M12	205	100	78	83	110
040315 ¹⁾			132		40	65	125	65	18	227	225	250	125	95	345	280	M12	205	100	78	83	110
050160	080	090			50	65	100	50	15	168	160	180	100	70	265	212	M12	130	100	33	37	39
050160			100		50	65	100	50	15	163	160	180	100	70	265	212	M12	130	100	33	37	39
050200	080	090	100	112	50	65	100	50	15	168	160	200	100	70	265	212	M12	150	100	44	48	49
050250	090	100	112		50	65	100	65	15	178	180	225	125	95	320	250	M12	170	100	47	50	54
050315 ¹⁾	112				50	65	125	65	17	194	225	280	125	95	345	280	M12	210	100	82	85	112
050315 ¹⁾		132	160		50	65	125	65	17	227	225	280	125	95	345	280	M12	210	100	82	85	112
065160	080	090			65	80	100	65	15	168	160	200	125	95	280	212	M12	150	100	46	47	49
065160			100		65	80	100	65	15	163	160	200	125	95	280	212	M12	150	100	46	47	49
065200	090	100	112		65	80	100	65	15	168	180	225	125	95	320	250	M12	165	140	50	51	53
065250	100	112			65	80	100	80	15	188	200	250	160	120	360	280	M16	185	140	65	68	70
065250			132		65	80	100	80	15	201	200	250	160	120	360	280	M16	185	140	65	68	70
065315	132	160			65	80	125	80	18	227	225	280	160	120	400	315	M16	220	140	94	97	117
080160	090				80	100	125	65	15	168	180	225	125	95	320	250	M12	170	140	49	53	55
080160		100	112		80	100	125	65	15	163	180	225	125	95	320	250	M12	170	140	49	53	55
080200	100	112			80	100	125	65	15	184	180	250	125	95	345	280	M12	180	140	61	63	66
080200			132		80	100	125	65	15	227	180	250	125	95	345	280	M12	180	140	61	63	66
080250	100	112			80	100	125	80	18	188	200	280	160	120	400	315	M16	200	140	72	75	76
080250			132	160	80	100	125	80	18	221	200	280	160	120	400	315	M16	200	140	72	75	76
080315	132	160			80	100	125	80	18	227	250	315	160	120	400	315	M16	235	140	94	99	130
100160 ¹⁾	100	112			100	125	125	80	18	214	200	280	160	120	360	280	M16	200	140	76	77	100
100160 ¹⁾			132		100	125	125	80	18	257	200	280	160	120	360	280	M16	200	140	76	77	100
100200	112				100	125	125	80	18	184	200	280	160	120	360	280	M16	200	140	69	72	89
100200		132			100	125	125	80	18	227	200	280	160	120	360	280	M16	200	140	69	72	89
100250	132	160			100	125	140	80	18	227	225	280	160	120	400	315	M16	210	140	82	84	91
100315	160	180			100	125	140	80	18	227	250	315	160	120	400	315	M16	245	140	99	104	125
125200 ¹⁾	132	160			125	150	140	80	18	257	250	315	160	120	400	315	M16	240	140	99	102	107
125250	160	180			125	150	140	80	18	227	250	355	160	120	400	315	M16	240	140	102	105	115
150200 ¹⁾	160	180			150	200	160	100	20	257	280	400	200	150	550	450	M20	265	140	120	125	135
150250 ¹⁾	160	180	200		150	200	160	100	20	236	280	400	200	150	500	400	M20	275	140	124	130	154
200250 ¹⁾	160	180	200		200	200	160	100	22	308	280	400	200	150	500	400	M20	310	180	186	191	--

1) Transnorm pump size not included in DIN 24255 / EN 733

2) Necessary length to remove – insert unit incl. motor

* Slots suitable for screws with dimension indicated. Screws are not included in the standard scope of supply.

Flange connection

to DIN EN 1092-2 PN 10 / 16									PN 10	PN 16	to DIN EN 1092-1 PN 10 / 16 (steel)								
DN _{1,2}	32	40	50	65	80	100	125	150	200	200	32	40	50	65	80	100	125	150	200
k	100	110	125	145	160	180	210	285	340	340	100	110	125	145	160	180	210	285	340
D	140	150	165	185	200	220	250	240	295	295	140	150	165	185	200	220	250	240	295
b _{fi}	18	18	20	20	22	24	26	26	26	30	18	18	18	18	20	20	22	22	24
	+4.0 / -3.0						+4.5 / -4.0				+2.0 / -1.3				+4.0 / -1.5				
d ₂	19	19	19	19	19	19	19	23	23	23	18	18	18	18	18	18	18	22	22
number	4	4	4	4	8	8	8	8	8	12	4	4	4	4	8	8	8	8	8

Motor dimensions

n = 1450 rpm

size	kW	b ₁ *	c ₁ *	D ₁	g*	h*	m*	m ₃	m ₄ *	m ₅	n ₃ *	n ₄	o ₁ *	s	w*	kg
80	0.55 / 0.75			200	158								238	10	135	13
90S	1.1			200	178								255	10	150	18
90L	1.5			200	178								280	10	150	22
100L	2.2 / 3.0			250	198								316	12	160	28 / 30
112M	4.0			250	223								334	12	179	45
132S	5.5			300	262								372	12	205	56
132M	7.5			300	262								410	12	205	64
160M	11.0			350	312								485	15	248	101
160L	15.0			350	312								529	15	248	110
180M	18.5	80	28	350	357	180	75	121	294	241	350	279	557	15	241	174
180L	22.0	80	28	350	357	180	75	121	332	279	350	279	595	15	279	185
200L	30.0	82	30	400	397	200	85	133	332	305	385	318	619	19	267	240

* Motor dimensions depend on the motor manufacturer.

Dimension table

n = 2900 rpm

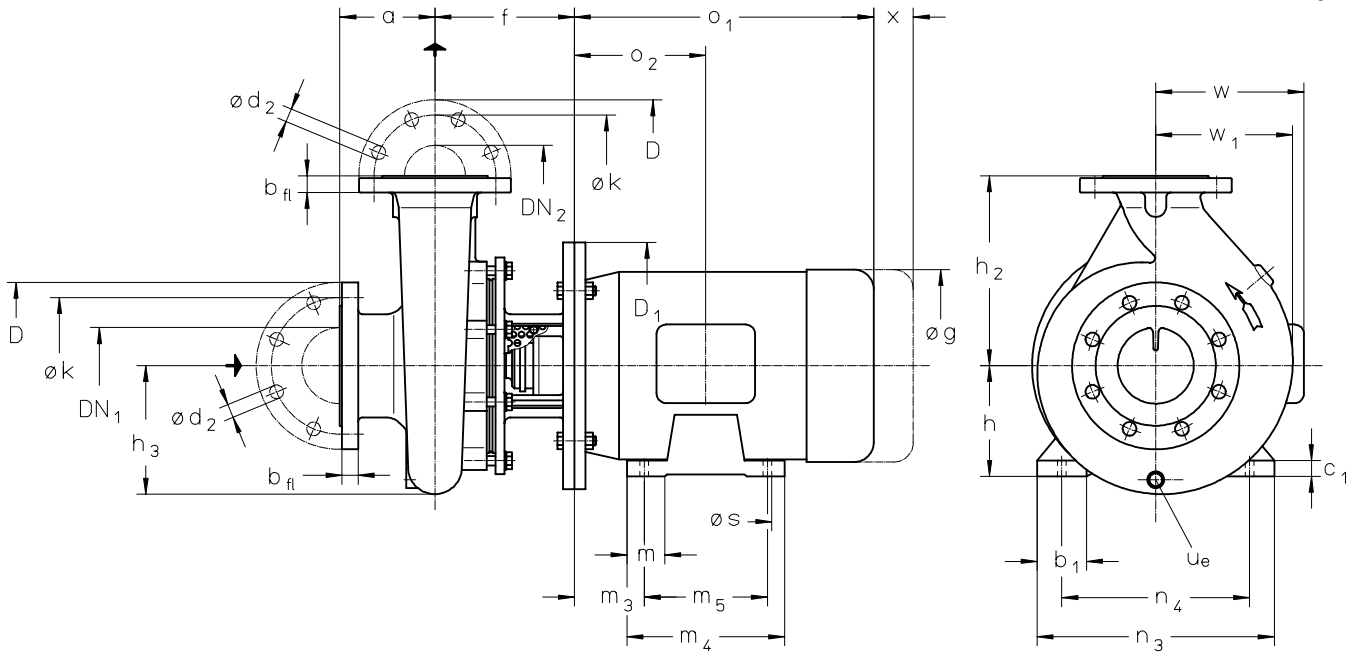

ue = drain connection G 1/4, from DN₂ 65 G 3/8

Dimensions in mm.

Size	Motor size n = 2900 rpm			DN ₂	DN ₁	a	f	h ₂	h ₃	w ₁	x ²⁾	Pump weight kg			
												0B	0C, 0E	4B	
032125	080	090	100	32	50	80	168	140	100	110	100	24	26	30	
032160 A	090			32	50	80	168	160	115	115	100	28	29	34	
032160 A		100	112	32	50	80	163	160	115	115	100	28	29	34	
032160 A				132	32	50	80	211	160	115	115	100	28	29	34
032160 B	090			32	50	80	168	160	115	120	100	28	29	34	
032160 B		100	112	32	50	80	163	160	115	120	100	28	29	34	
032160 B				132	32	50	80	211	160	115	120	100	28	29	34
032200 A	100	112		32	50	80	168	180	130	130	100	32	33	41	
032200 A			132	32	50	80	211	180	130	130	100	32	33	41	
032200 B	100	112		32	50	80	168	180	135	140	100	32	33	41	
032200 B			132	32	50	80	211	180	135	140	100	32	33	41	
032250 ¹⁾	160			32	50	100	211	225	155	160	100	42	44	52	
040125	090	100	112	40	65	80	163	140	100	110	100	30	32	33	
040160	100	112		40	65	80	163	160	125	130	100	32	34	36	
040160			132	40	65	80	211	160	125	130	100	32	34	36	
040200	100	112		40	65	100	168	180	135	145	100	44	45	47	
040200			132	40	65	100	216	180	135	145	100	44	45	47	
040250	132	160	180	40	65	100	211	225	160	160	100	49	51	52	
050125	090	100	112	50	65	100	168	160	115	120	100	30	34	37	
050125				132	50	65	100	211	160	115	120	30	34	37	
050160	112			50	65	100	163	180	125	130	100	33	37	39	
050160		132	160	50	65	100	211	180	125	130	100	33	37	39	
050200	132	160	180	50	65	100	211	200	145	150	100	44	48	49	
050250	160	180		50	65	100	211	225	165	170	100	47	50	54	
065125	112			65	80	100	168	180	130	140	100	37	39	45	
065125		132		65	80	100	211	180	130	140	100	37	39	45	
065160	132	160		65	80	100	211	200	135	150	100	46	47	49	
065200	160	180		65	80	100	211	225	160	165	140	50	51	53	
065250	160	180	200	65	80	100	221	250	180	185	140	65	68	70	
080160	160			80	100	125	211	225	155	170	140	49	53	55	
080200	160	180	200	80	100	125	227	250	175	180	140	61	63	66	
100160 ¹⁾	160	180	200	100	125	125	257	280	185	200	140	76	77	100	
100200	180	200		100	125	125	227	280	190	200	140	69	72	89	

1) Transnorm pump size not included in DIN 24255 / EN 733

2) Necessary length to remove – insert unit incl. motor

* Slots suitable for screws with dimension indicated. Screws are not included in the standard scope of supply.

Flange connections

to DIN EN 1092-2 PN 10 / 16									PN 10	PN 16	to DIN EN 1092-1 PN 10 / 16 (steel)								
DN _{1,2}	32	40	50	65	80	100	125	150	200	200	32	40	50	65	80	100	125	150	200
k	100	110	125	145	160	180	210	285	340	340	100	110	125	145	160	180	210	285	340
D	140	150	165	185	200	220	250	240	295	295	140	150	165	185	200	220	250	240	295
b _{fl}	18	18	20	20	22	24	26	26	26	30	18	18	18	18	20	20	22	22	24
	Toleranz +4.0 / -3.0						Toleranz +4.5 / -4.0				Toleranz +2.0 / -1.3				Toleranz +4.0 / -1.5				
d ₂	19	19	19	19	19	19	19	23	23	23	18	18	18	18	18	18	18	22	22
number	4	4	4	4	8	8	8	8	8	12	4	4	4	4	8	8	8	8	8

Motor dimensions

n = 2900 rpm

size	kW	b ₁ *	c ₁ *	D ₁	g*	h*	m*	m ₃	m ₄ *	m ₅	n ₃ *	n ₄	o ₁ *	s	w*	kg
80	0.75 / 1.1	35	13	200	158	80	40	50	126	100	149	125	238	10	135	13 / 17
90S	1.5	38	15	200	178	90	42	56	131	100	164	140	255	10	150	19
90L	2.2	38	15	200	178	90	42	56	156	125	164	140	280	10	150	20
100L	3.0	44	15	250	198	100	50	63	173	140	188	160	316	12	160	32
112M	4.0	48	18	250	223	112	50	70	177	140	220	190	334	12	179	40
132S	5.5 / 7.5	51	20	300	262	132	55	89	187	140	248	216	372	12	205	59 / 67
160M	11.0 / 15.0	64	20	350	312	160	65	108	256	210	308	254	485	15	248	114
160L	18.5	64	20	350	312	160	65	108	300	254	308	254	529	15	248	134
180M	22.0	80	28	350	357	180	75	121	294	241	350	279	557	15	241	165
200L	30.0 / 37.0	82	30	400	397	200	85	133	332	305	385	318	619	19	267	232 / 249

* Motor dimensions depend on the motor manufacturer.

Data regarding size - order information

Type	Size	Hydraulic + Bearing				Shaft Sealing			Material			Casing Gasket	
		A • First hydraulic B • Second hydraulic • 3 Volute casing with feet, one ball bearing in bearing bracket, greased-lubricated • 4 Volute casing without feet, one ball bearing in bearing bracket, greased-lubricated				BH3 Unbalanced single standard mechanical seal, seal face mat. SiC/carbon, elastomer EPDM BHS Unbalanced single standard mechanical seal, seal face mat. SiC/ SiC, elastomer FPM (Viton) BHJ Unbalanced single standard mechanical seal, seal face mat. SiC/carbon, elastomer FPM (Viton)			0B Cast iron GG25 0C Cast iron GG25, Bronze G-CuSn10 impeller 0E Cast iron GG25, stainless steel 1.4408 impeller 4B Stainless steel 1.4408			2 Confined flat gasket of EWP 210 4 Confined flat gasket of PTFE	
		A3	A4	B3	B4	BH3	BHS	BHJ	0B 2	0C 2	0E 2	4B 2	4B 4
ZLKD	032125		●			●	●	●	●	●	●	●	●
	032160	●	●	●	●	●	●	●	●	●	●	●	●
	032200	●	●	●	●	●	●	●	●	●	●	●	●
	032250	●	●			●	●	●	●	●	●	●	●
	040125		●			●	●	●	●	●	●	●	●
	040160	●	●			●	●	●	●	●	●	●	●
	040200	●	●			●	●	●	●	●	●	●	●
	040250	●	●			●	●	●	●	●	●	●	●
	040315	●				●	●	●	●	●	●	●	●
	050125		●			●	●	●	●	●	●	●	●
	050160	●	●			●	●	●	●	●	●	●	●
	050200	●	●			●	●	●	●	●	●	●	●
	050250	●	●			●	●	●	●	●	●	●	●
	050315	●				●	●	●	●	●	●	●	●
	065125		●			●	●	●	●	●	●	●	●
	065160	●	●			●	●	●	●	●	●	●	●
	065200	●	●			●	●	●	●	●	●	●	●
	065250	●	●			●	●	●	●	●	●	●	●
	065315	●				●	●	●	●	●	●	●	●
	080160	●	●			●	●	●	●	●	●	●	●
	080200	●	●			●	●	●	●	●	●	●	●
	080250	●				●	●	●	●	●	●	●	●
	080315	●				●	●	●	●	●	●	●	●
	100160	●	●			●	●	●	●	●	●	●	●
100200	●	●			●	●	●	●	●	●	●	●	
100250	●				●	●	●	●	●	●	●	●	
100315	●				●	●	●	●	●	●	●	●	
125200	●				●	●	●	●	●	●	●	●	
125250	●				●	●	●	●	●	●	●	●	
150200	●				●	●	●	●	●	●	●	●	
150250	●				●	●	●	●	●	●	●	●	
200250	●				●	●	●	●	●	●	●	●	

Example for order:

Type				Size						Hydr+ Bear.	Shaft Seal			Mat.	Cas. Gask.	Motor Size				
Z	L	K	D																	
Z	L	K	D	0	8	0	2	0	0	A	4	B	H	3	0	E	2	1	8	0

The complete pump ZLKD 080200 A4 BH3 0E 2 suitable for 22.0 kW – 2900 rpm => motor size 180 has the order code : ZLKD 080200 A4 BH3 0E 2 180

Pls. take applicable motors from the dimension table located in page 5 up to 7.

COPYRIGHT WARNING

Please read this notice

The material you are viewing in this document is protected by Copyright and may only be used in accordance with Copyright, Designs and Patent legislation.

It is not permitted to copy - either in full or in part - nor substantially extract, reproduce or re-use any of the contents of this document in any material form or in any medium without permission from the Copyright holders or their assignees. Any unlawful use of the material in this document may result in claims for civil remedies, including an injunction to restrain further use and a claim for damages; or may result in criminal penalties.

Sterling Fluid Systems (Spain), S.A.

Vereda de los Zapateros s/n, Pozuelo de Alarcón 28223 Madrid, Spain.
Telephone +34 91 709 1310 Telefax +34 91 715 9700. E-mail mibsa@stnet.es