

STERLING^{multi} Type MSH

Description

STERLING^{multi} pumps are horizontal multistage centrifugal pumps of ring-section design, which meet the technical requirements of ISO 5199 / EN 25199.

The type MSH is developed for the high pressure range up to PN 160.

The advanced modular design reduces the number of parts whilst maximising interchangeability.

Optimal selection of impeller diameter and diffuser size for each ensures that the pump closely match the required duty conditions.



Applications

Pumps of the STERLING^{multi} range type MSH meet the specific requirements of many applications, such as:

- Waterworks and water supply
- Boiler feed
- Pressure boosting
- Irrigation
- High pressure cleaning
- Heating
- Condensate systems
- Reverse osmosis
- Chemical and Process
- and many more ...

Technical Data

Flowrate	max. 250 m ³ /h
Head	max. 1600 m
Speed	max. 3600 rpm
Temperature	-10 to +180°C
Pressure Rating	max. 160 bar
Shaft seal	- packed gland - mechanical seal
Direction of rotation	counter-clockwise, when viewed from discharge side

Construction

Different hydraulic impeller and diffuser sizes can be installed in a standardised casing, thus enabling the pump to be designed exactly for the working point required. The first stage of each pump size is equipped with suction impeller.

Axial thrust is balanced by a combination of a balance drum and balance disc. For special application a additional balance disc lift-off device is available. The balancing line is returned to the suction casing or in the upstream vessel. Standard suction casing construction is with axial or radial inlet nozzles.

The shaft is sealed by packing or mechanical seal. A variety of designs are available (cooled or uncooled).

The pump rotor is supported on the discharge side by oil-lubricated anti-friction bearing and on the suction side by a self-adjusting sleeve bearing lubricated by the pumped liquid or by oil-lubricated anti-friction bearings.

The casing components are sealed by O-rings. The pump casings are held together by external tie rods. The pump feet are bolted to the suction casing such as to facilitate different nozzle positions for extra piping flexibility.

The pump is driven from the discharge side or from the suction side. All pump sizes can be provided with one or more dummy stages or with interstage bleed-off device, if required.

Options

- Special materials
- Monitoring systems

Type MSH

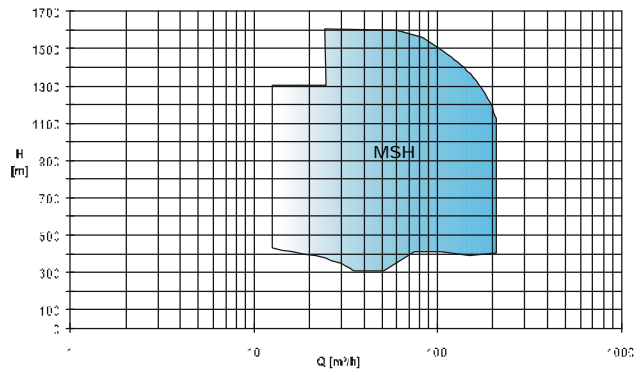

Suction Impeller

First stage impeller ensures reliable operation with low NPSH conditions.

Suction Position

Adaptable design allows for either radial or axial suction.

Discharge Nozzle

Large diameter provides low flow velocity and quiete operation. Different nominal pressure stages are available.

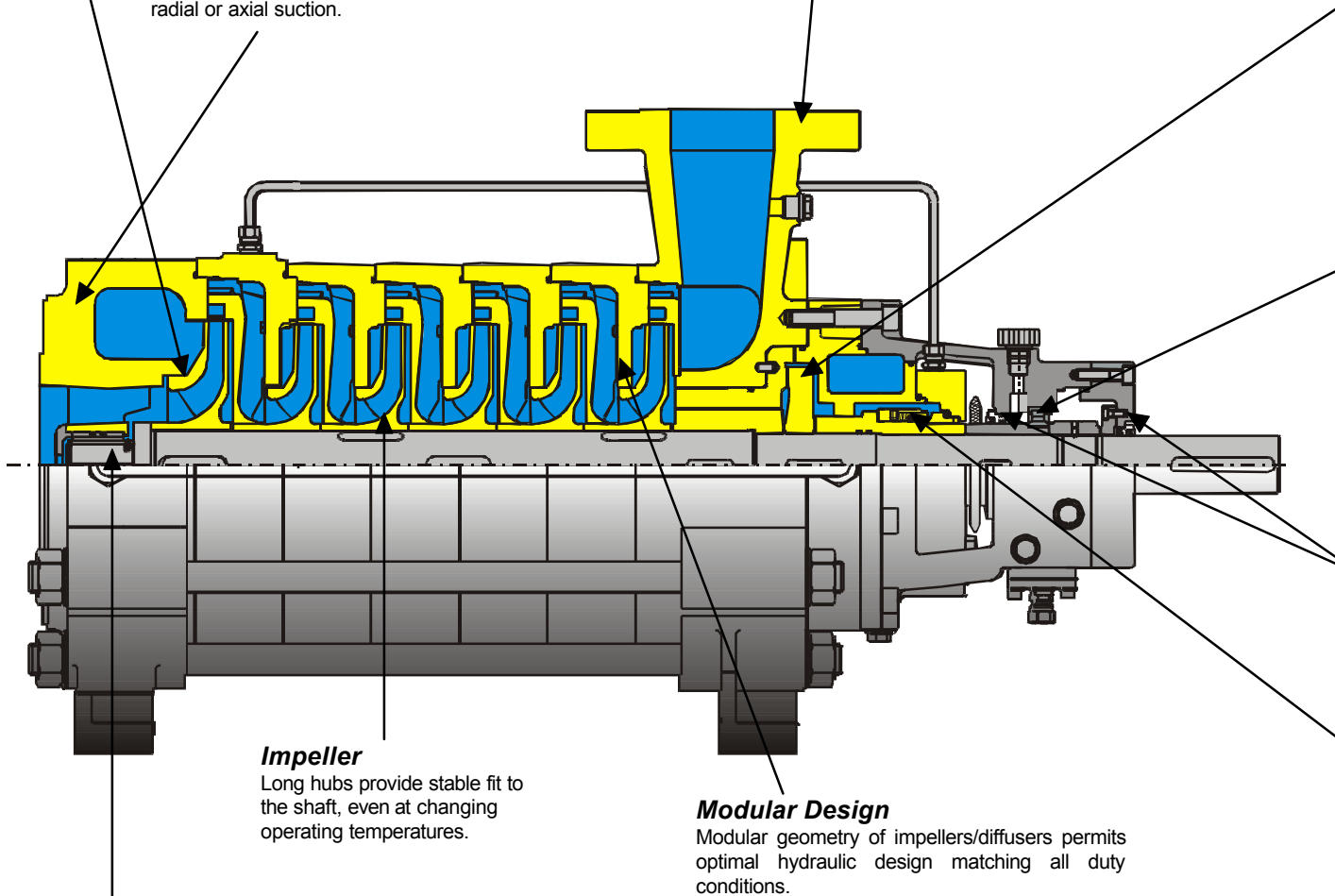

Impeller

Long hubs provide stable fit to the shaft, even at changing operating temperatures.

Modular Design

Modular geometry of impellers/diffusers permits optimal hydraulic design matching all duty conditions.

Product Lubricated Sleeve Bearing

Self-aligning bearing for higher reliability.

Options

Radial inlet

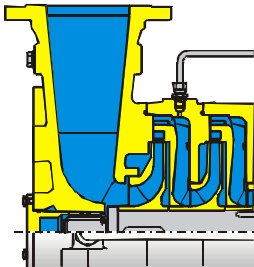

Balance disc lift-off device

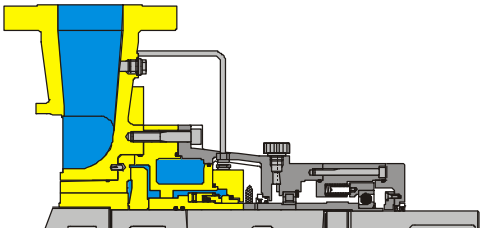

Interstage bleed-off

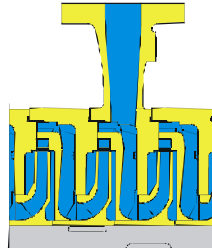

Destaging device

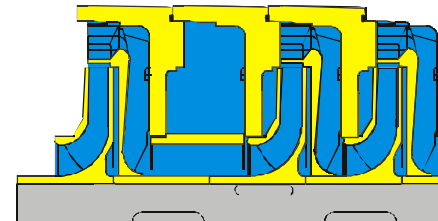

Inboard and outboard anti-friction bearing (drive on suction side)

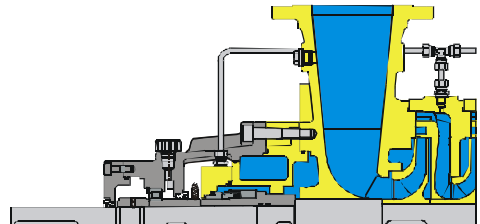

Axial thrust balancing

Proven combination of drum and disc balances hydraulic axial thrust over the entire operating range.

Oil lubricated inboard roller bearing

External cooling is possible for severe operating conditions.

Labyrinth seals

Bearing protection to secure extended life time.

Shaft sealing

- uncooled and cooled single-acting mechanical seal
- uncooled or cooled packed gland

Range Coverage 50 Hz

n = 1450 rpm

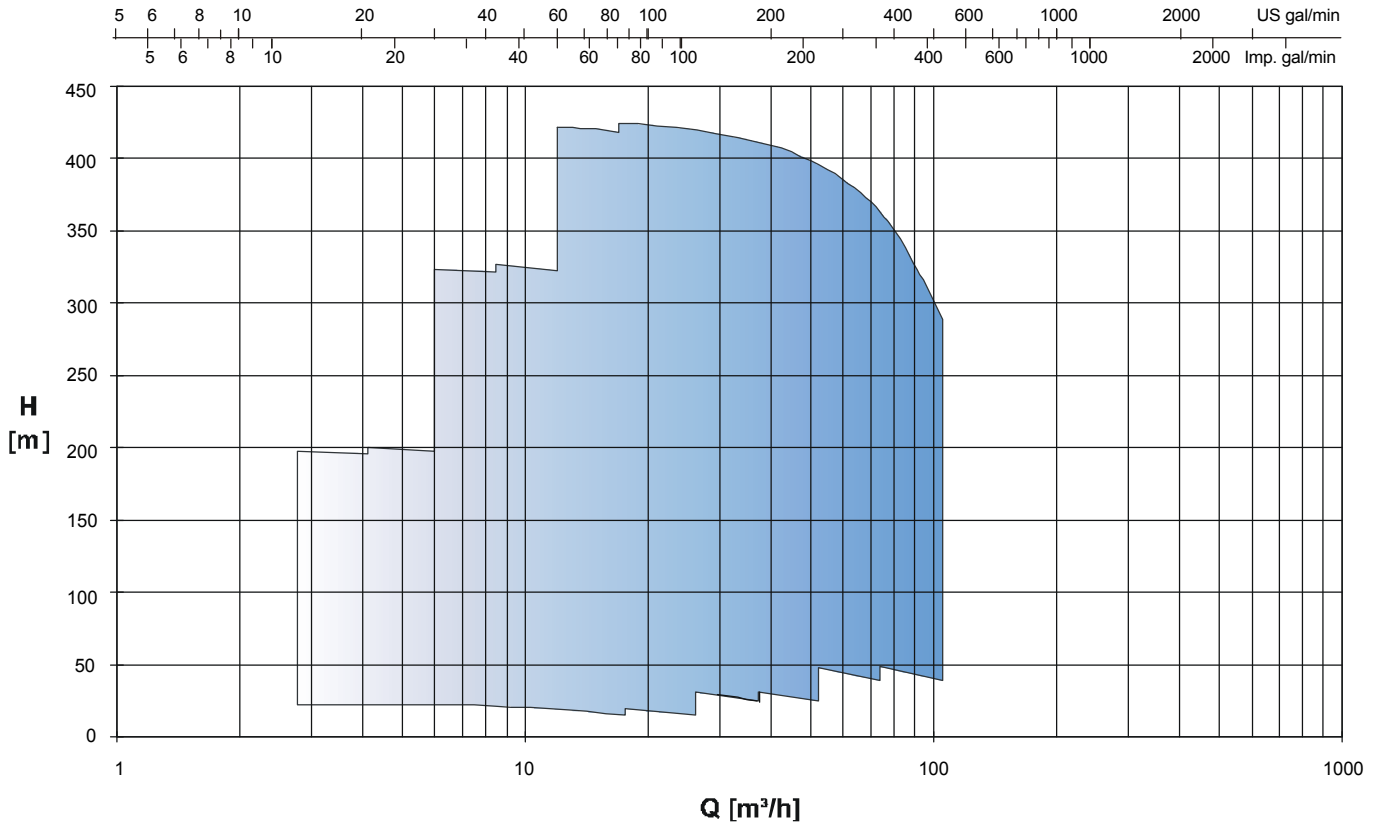

n = 2950 rpm

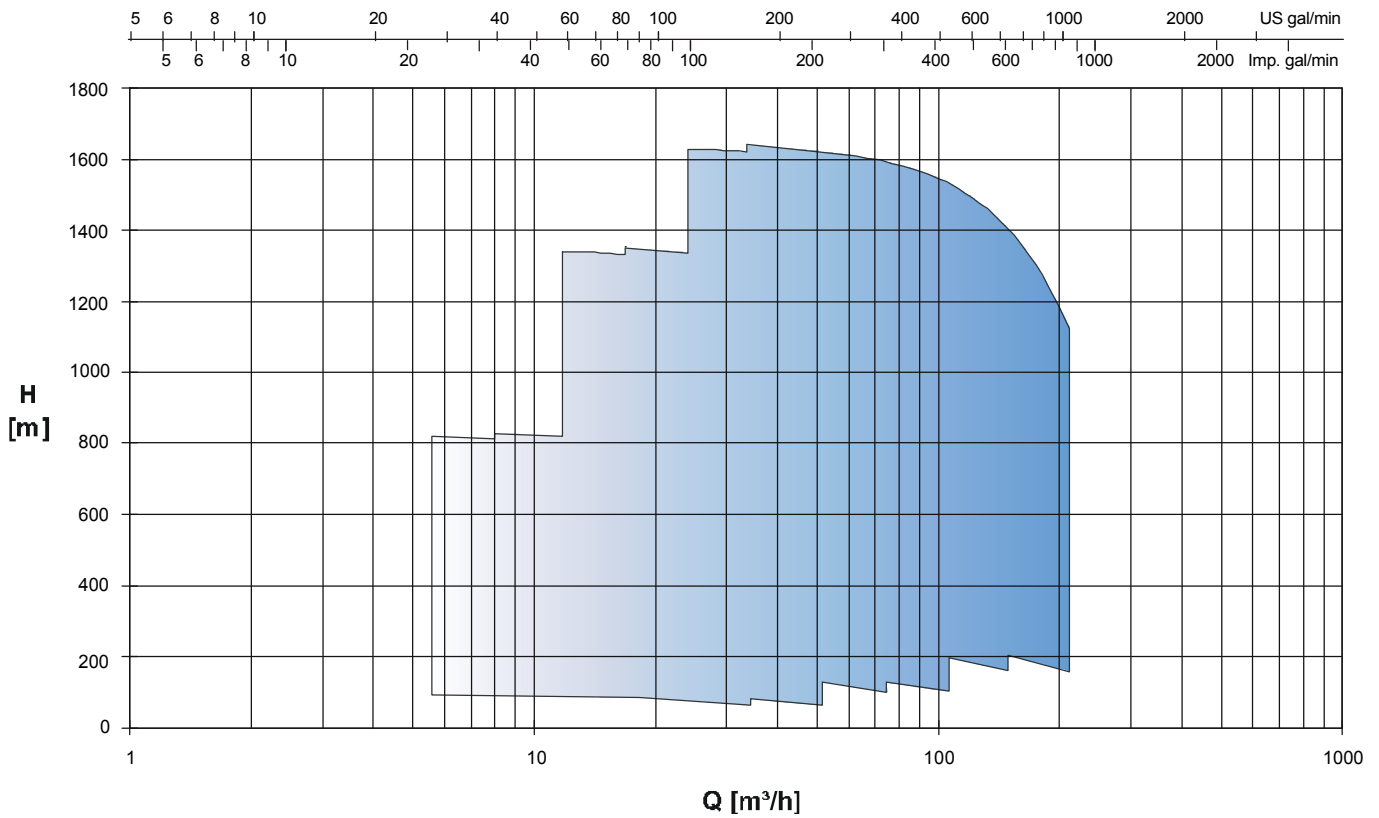

Range Coverage 60 Hz

n = 1750 rpm

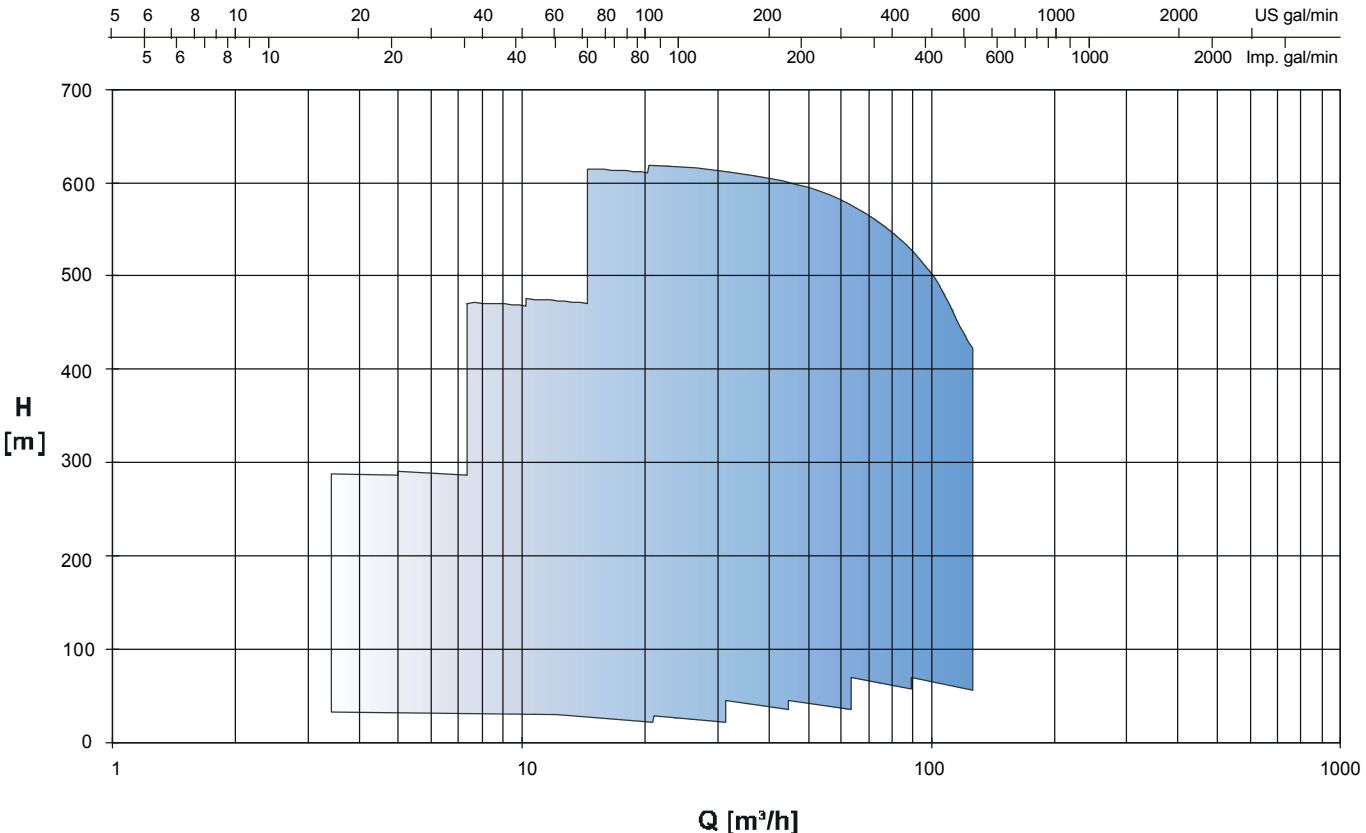

n = 3550 rpm

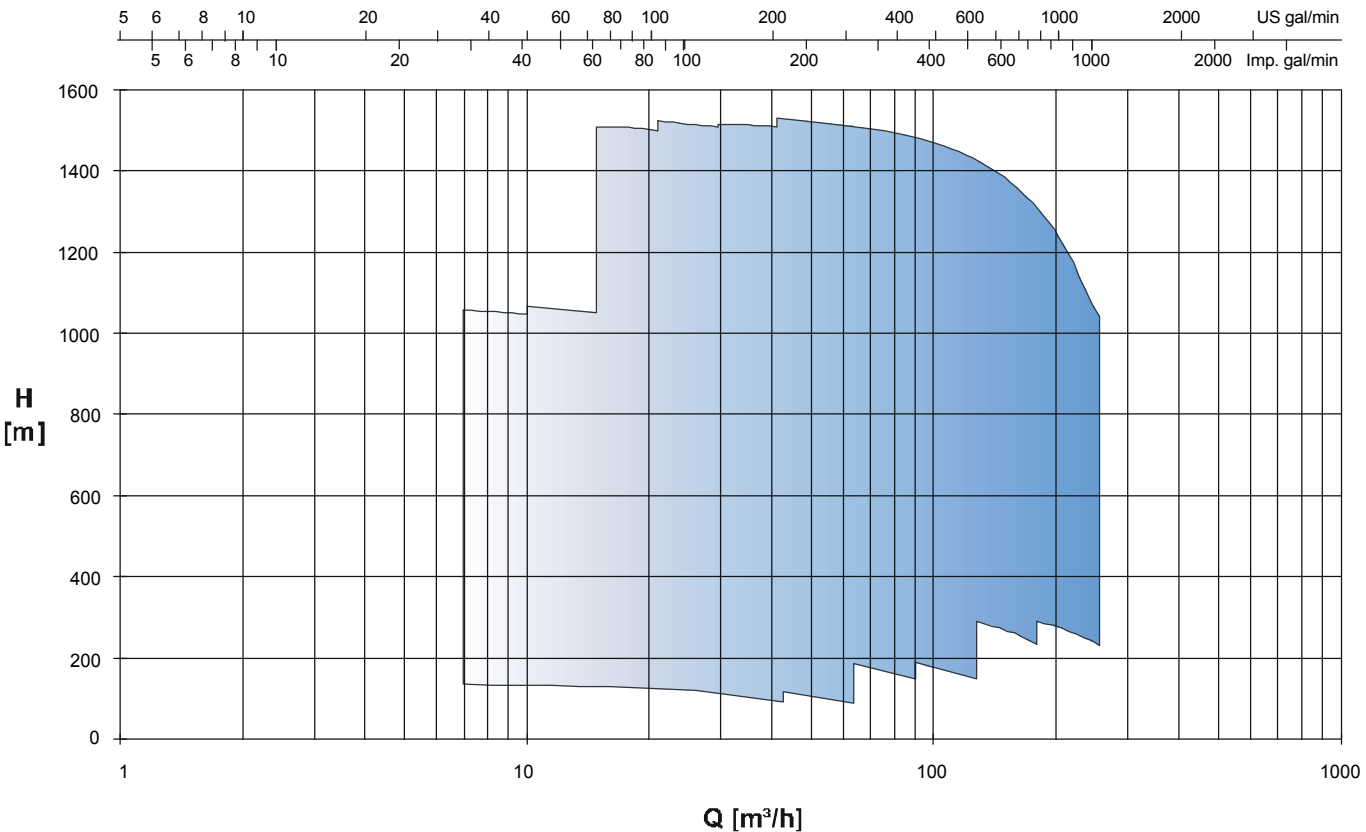

Nozzle position (viewed from discharge side)

Discharge casing



radial top

Suction casing



axial



radial horizontal left



radial top



radial horizontal right

Flange dimensions

ISO/EN/DIN

size	Flange dimensions DN (mm)			Flange Ratings	
				material of construction Chrome Steel	
	suction side axial	radial	discharge side	suction side	discharge side
050	100	80	50	drilled to	drilled to
065	125	100	65	DIN 2543, PN 16 DIN 2544, PN 25	DIN 2548, PN 160
100	150	125	100		

ANSI

size	Flange dimensions DN (inch)			Flange Ratings	
				material of construction Chrome Steel	
	suction side axial	radial	discharge side	suction side	discharge side
050	4"	3"	2"	drilled to	drilled to ANSI B 16.5, 600 RF*
065	5"	4"	2 1/2"	ANSI B 16.5, 300 RF	gebohrt nach
100	6"	5"	4"		ANSI B 16.5, 600 RF, 900 RF*

* = higher pressures on request

Shaft sealing

Mechanical seal arrangement

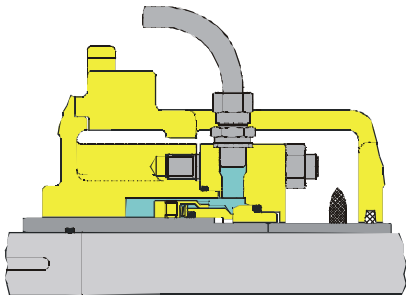

uncooled, balanced

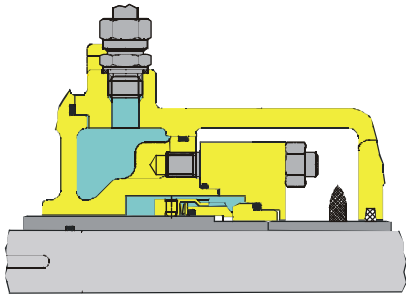

cooled, balanced

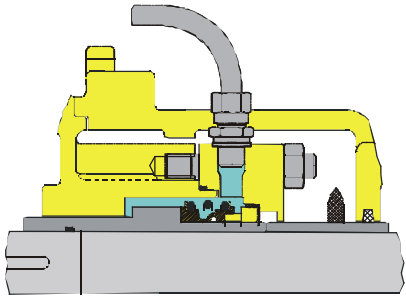

uncooled, unbalanced

Packed gland arrangement

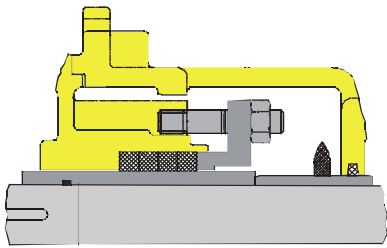

uncooled

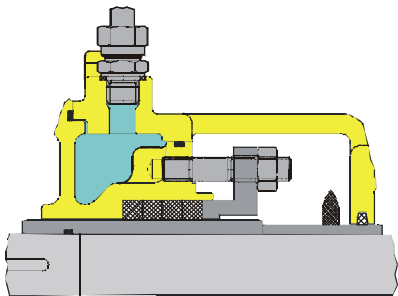

with jacket-cooling

Sectional drawing MSH with axial inlet, without balance disc lift-off device

Size 050

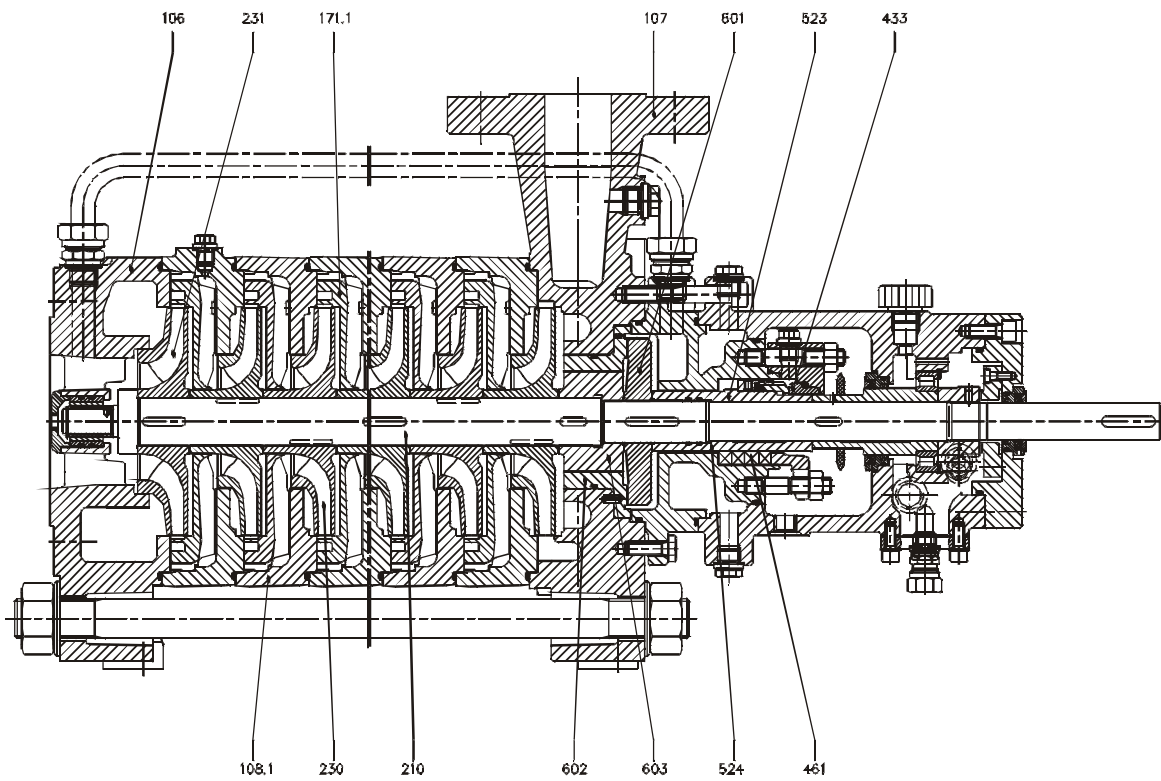

Size 065 and 100

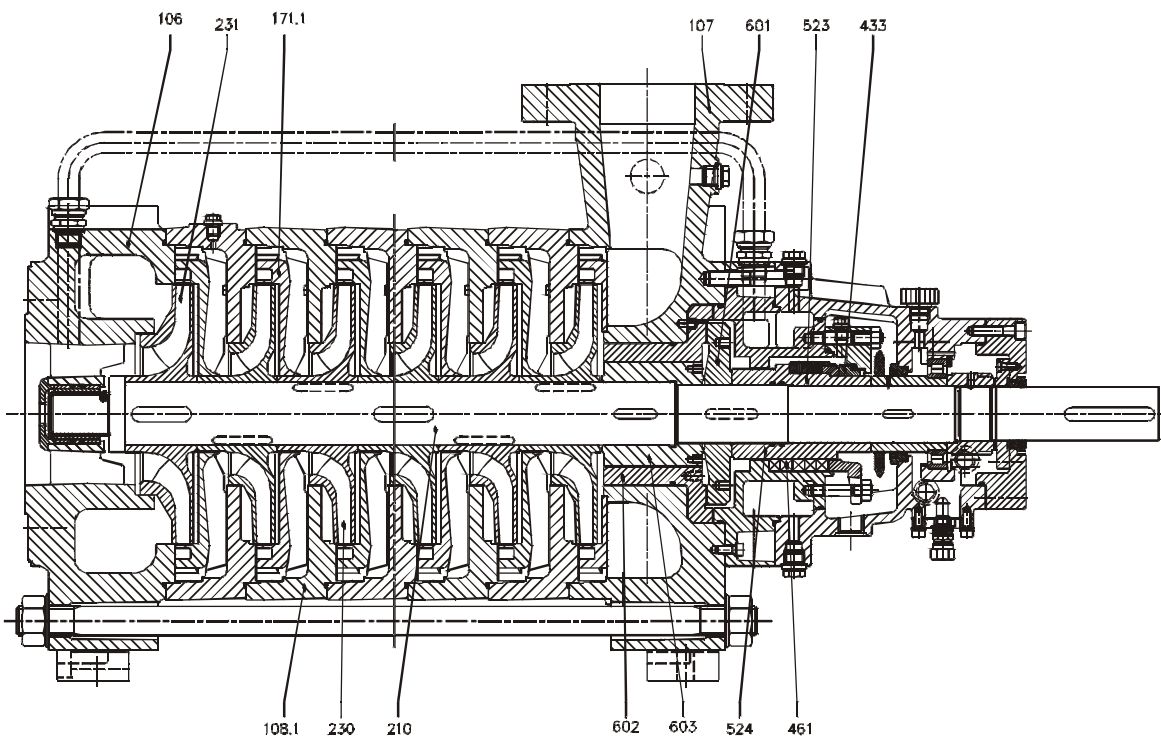

For material of construction please see page 14.

Sectional drawing MSH with axial inlet, with balance disc lift-off device

Size 050

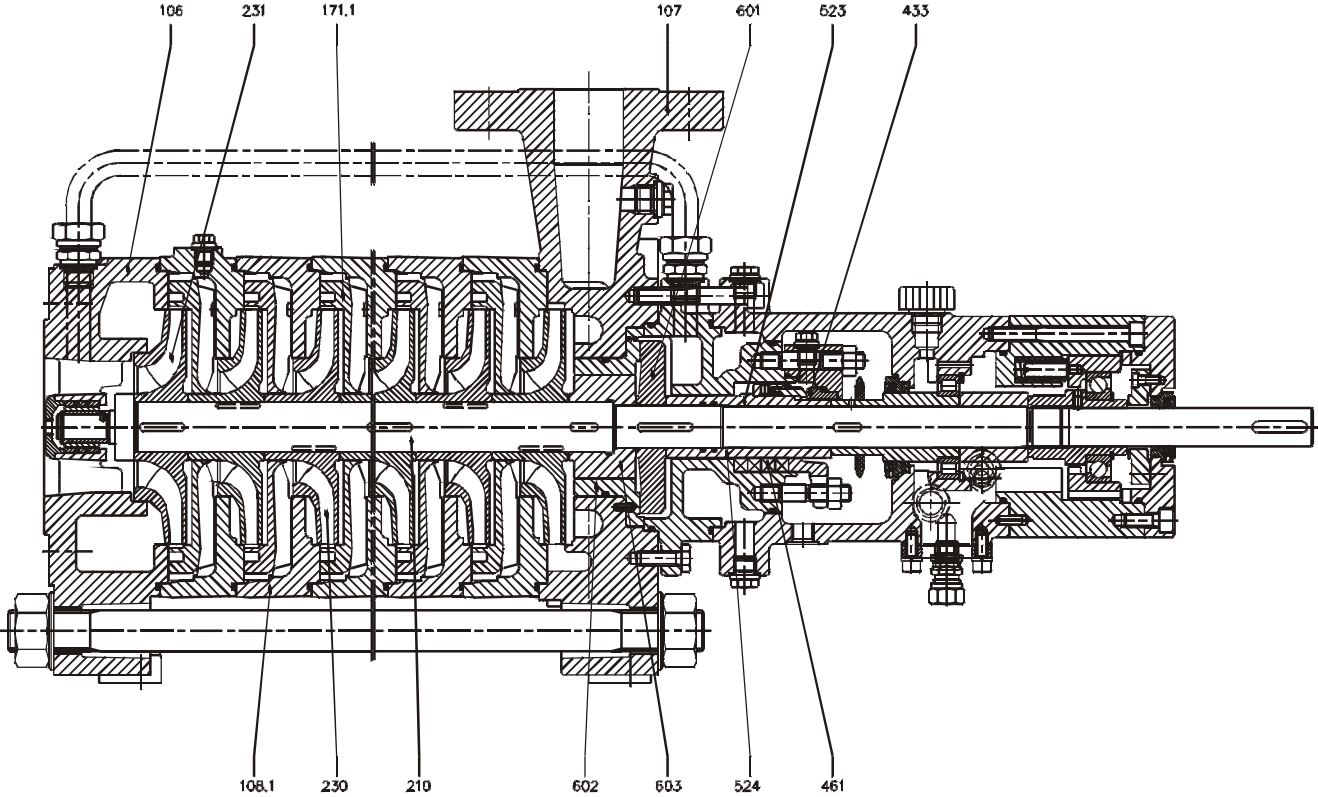

Size 065 and 100

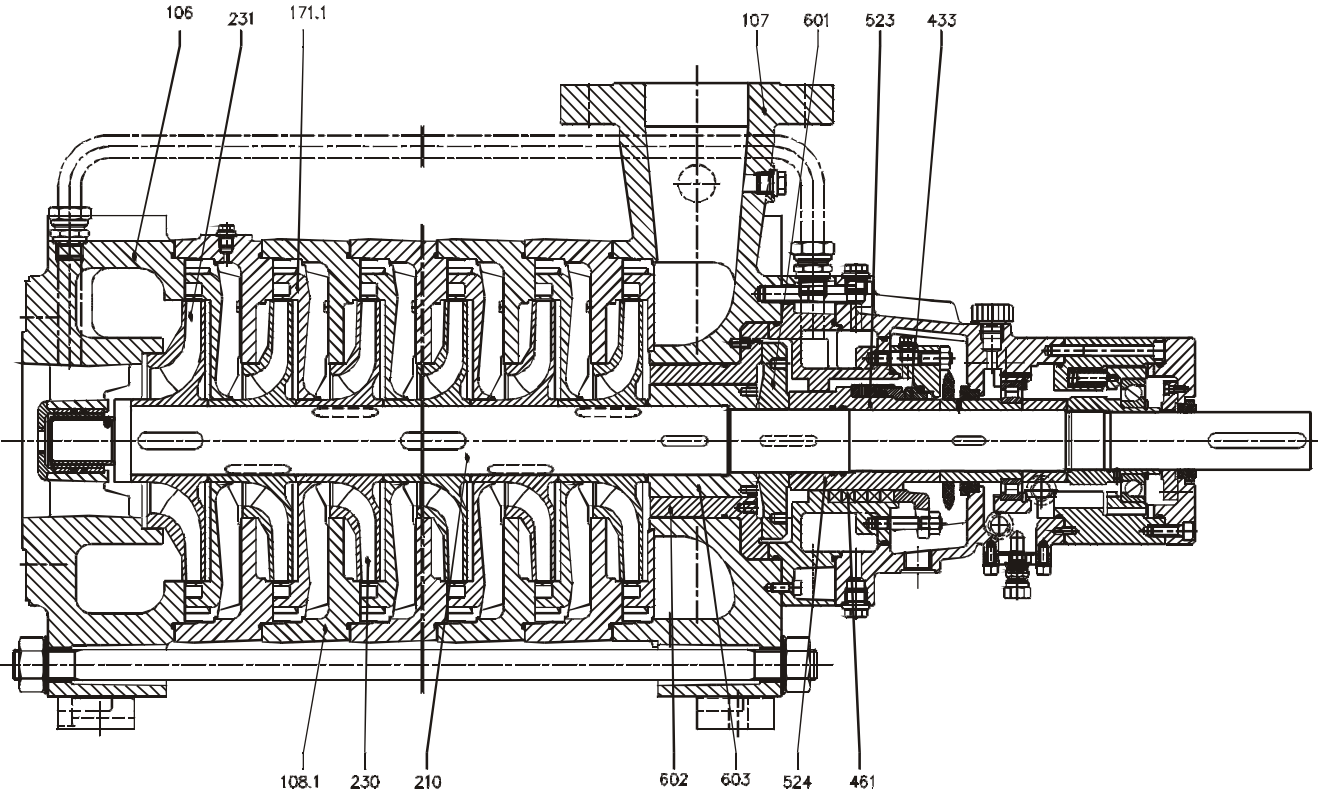

For material of construction please see page 14.

Sectional drawing MSH with radial inlet, without balance disc lift-off device

Size 050

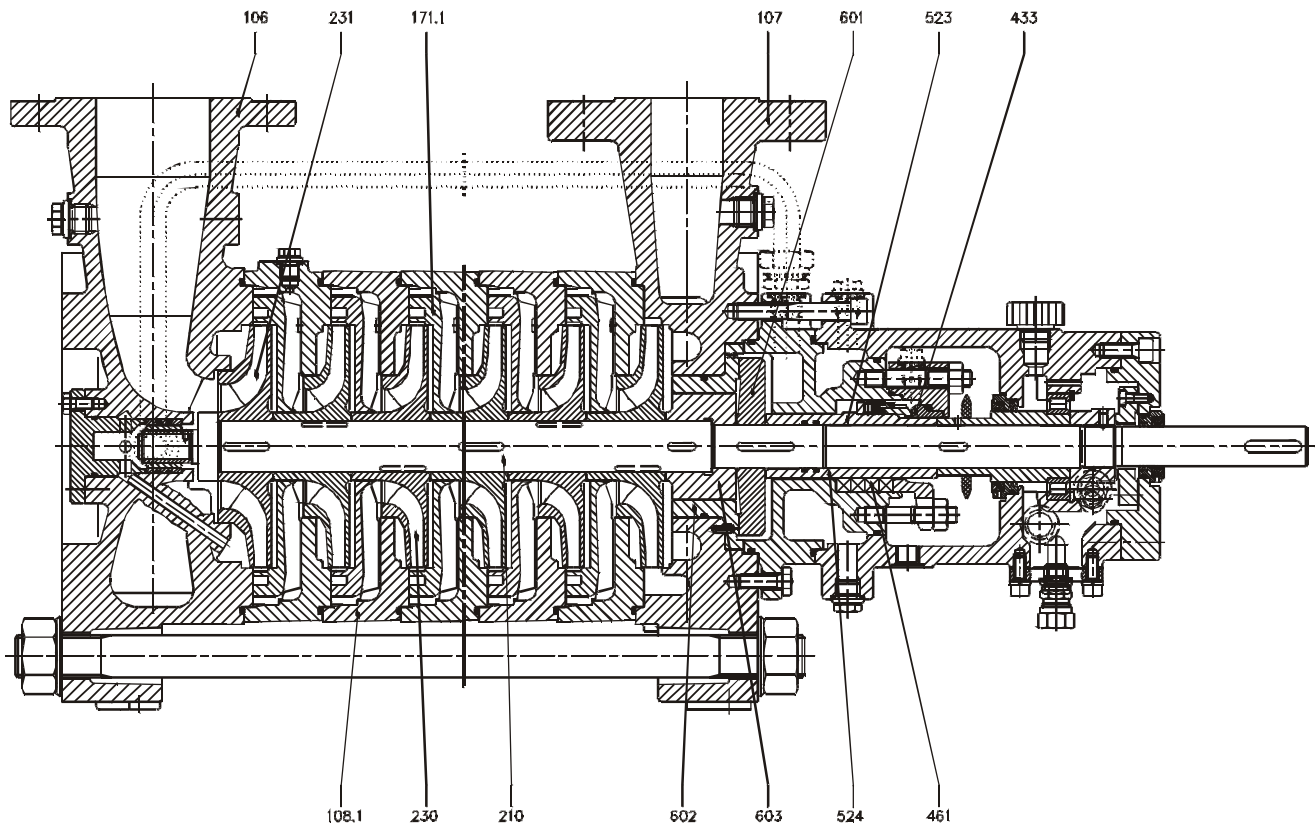

Size 065 and 100

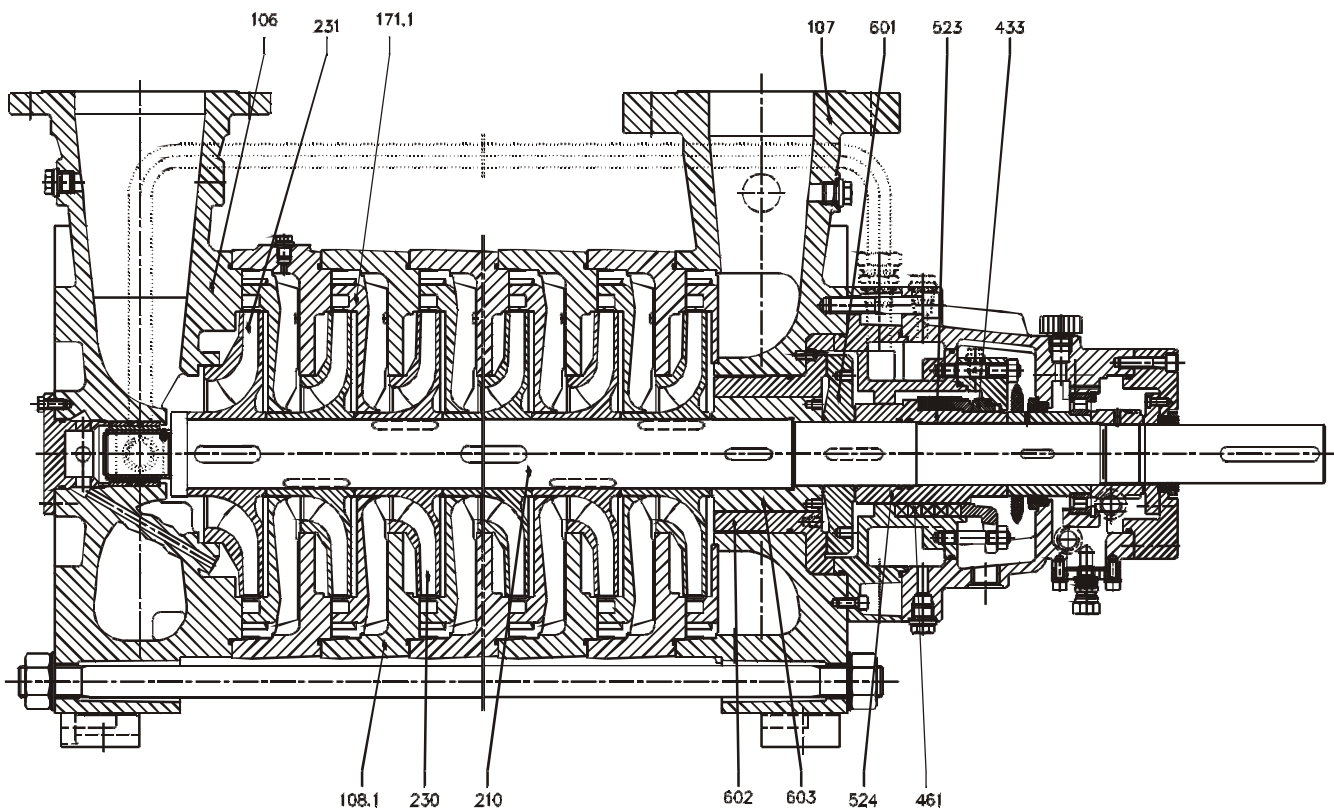

For material of construction please see page 14.

Sectional drawing MSH with radial inlet, with balance disc lift-off device

Size 050

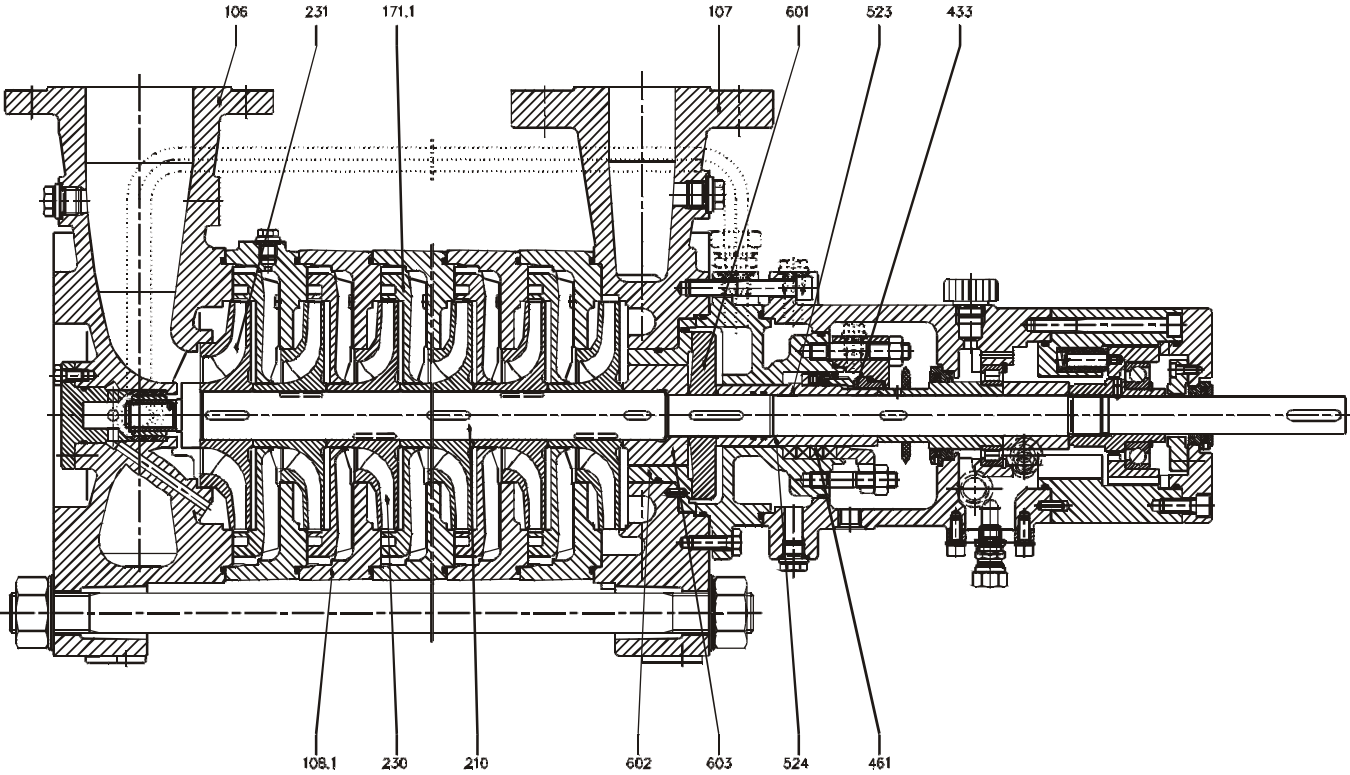

Size 065 and 100

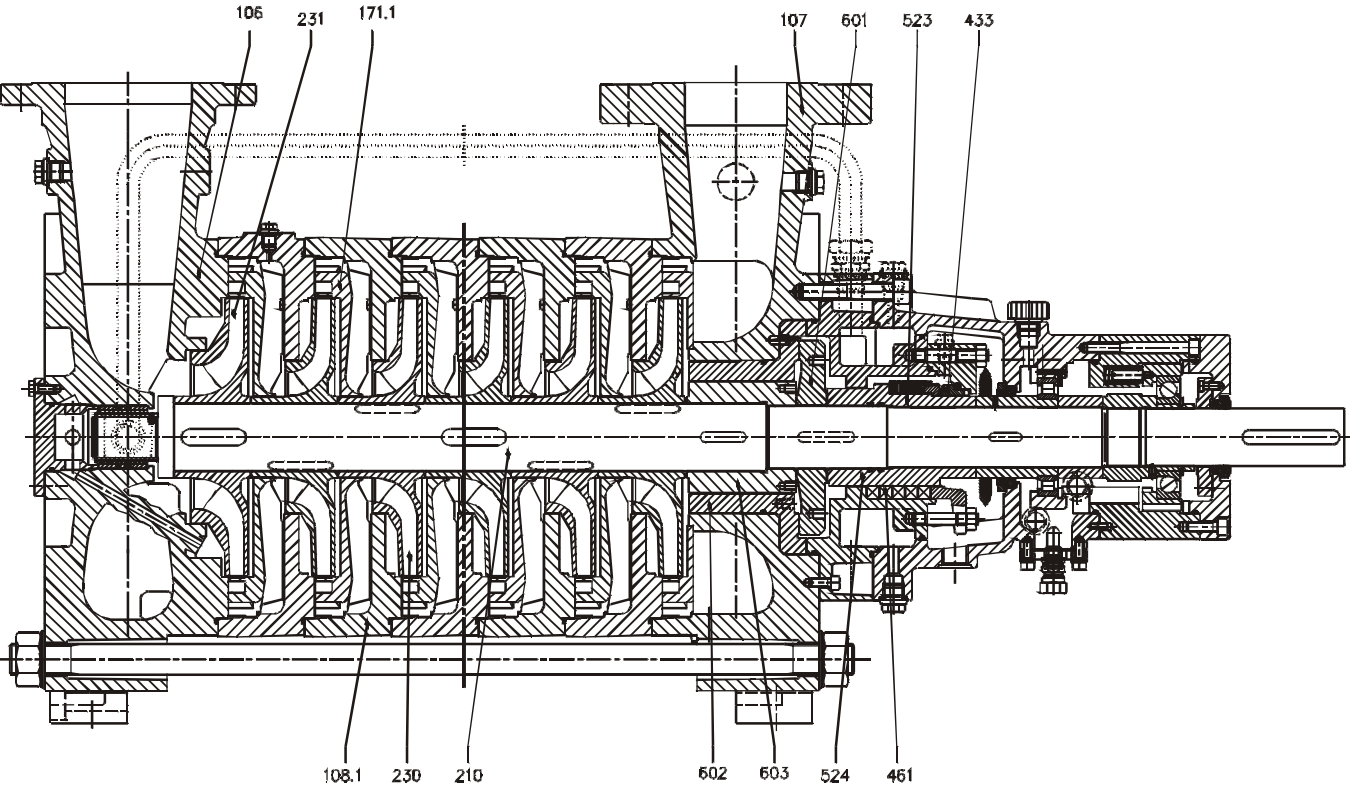

For material of construction please see page 14.

**Sectional drawing MSH with inboard and outboard anti-friction bearing,
without balance disc lift-off device**

Size 050

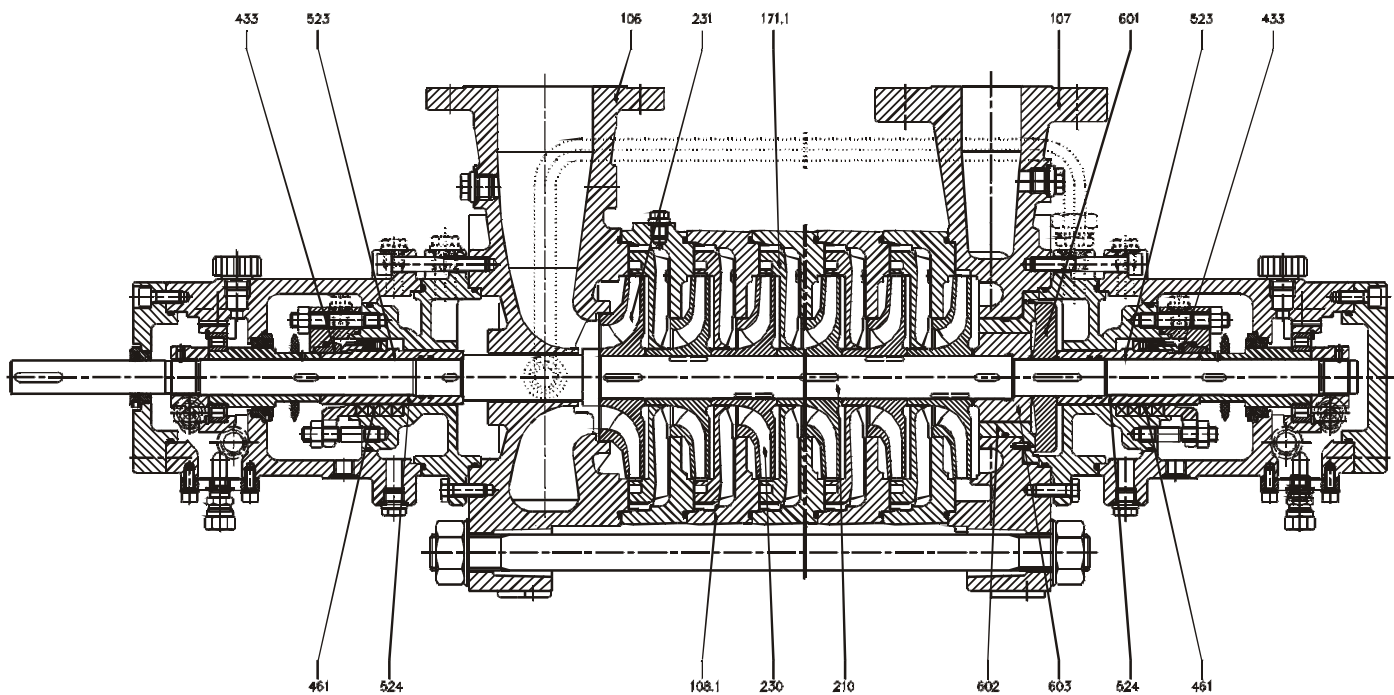

Size 065 and 100

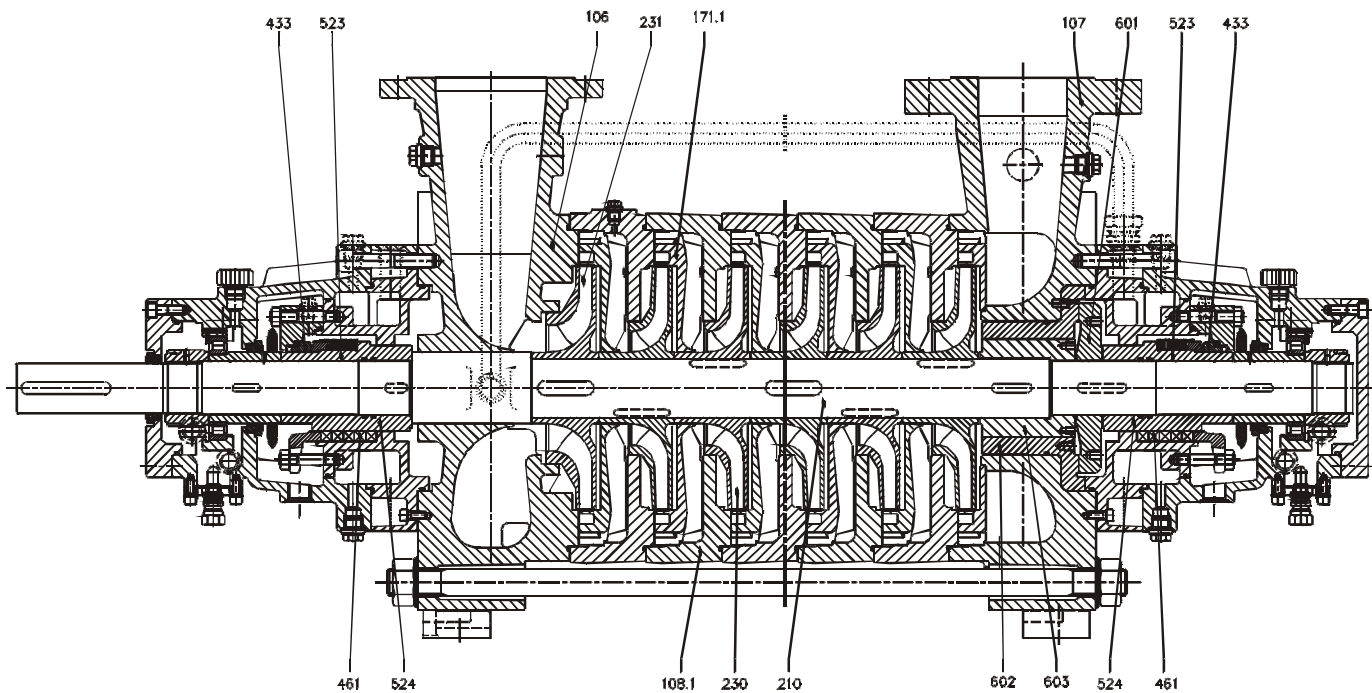

For material of construction please see page 14.

**Sectional drawing MSH with inboard and outboard anti-friction bearing,
with balance disc lift-off device**

Size 050

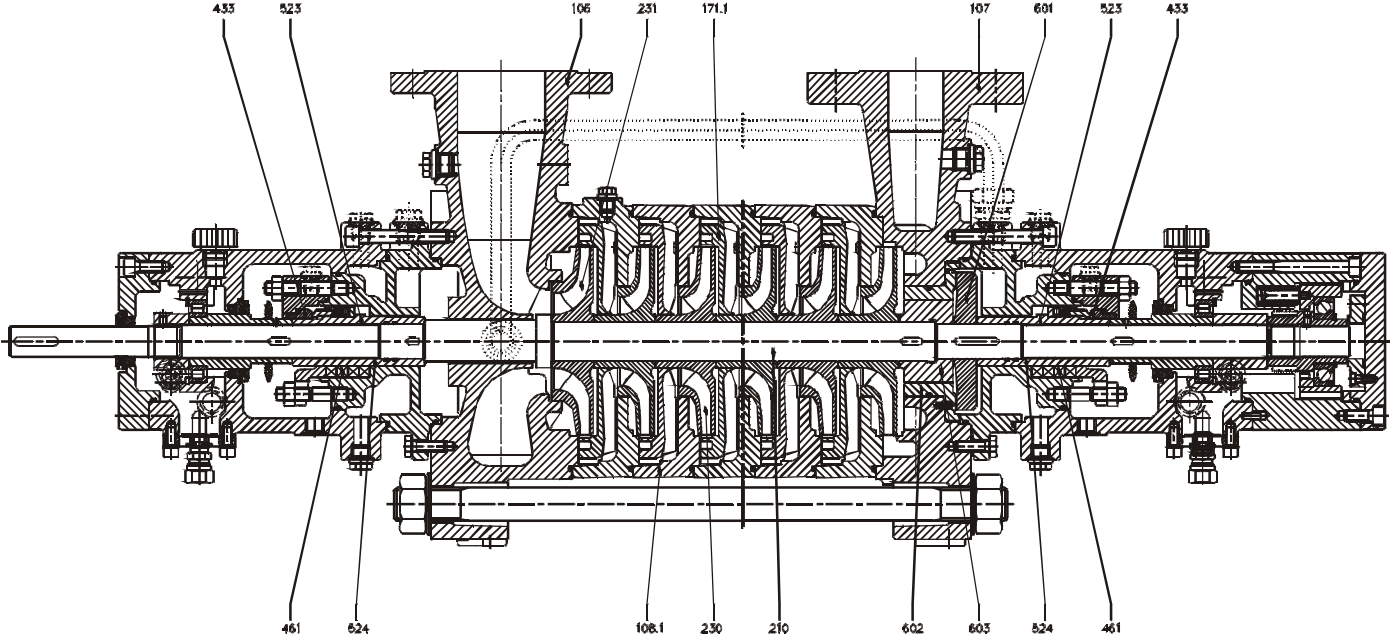

Size 065 and 100

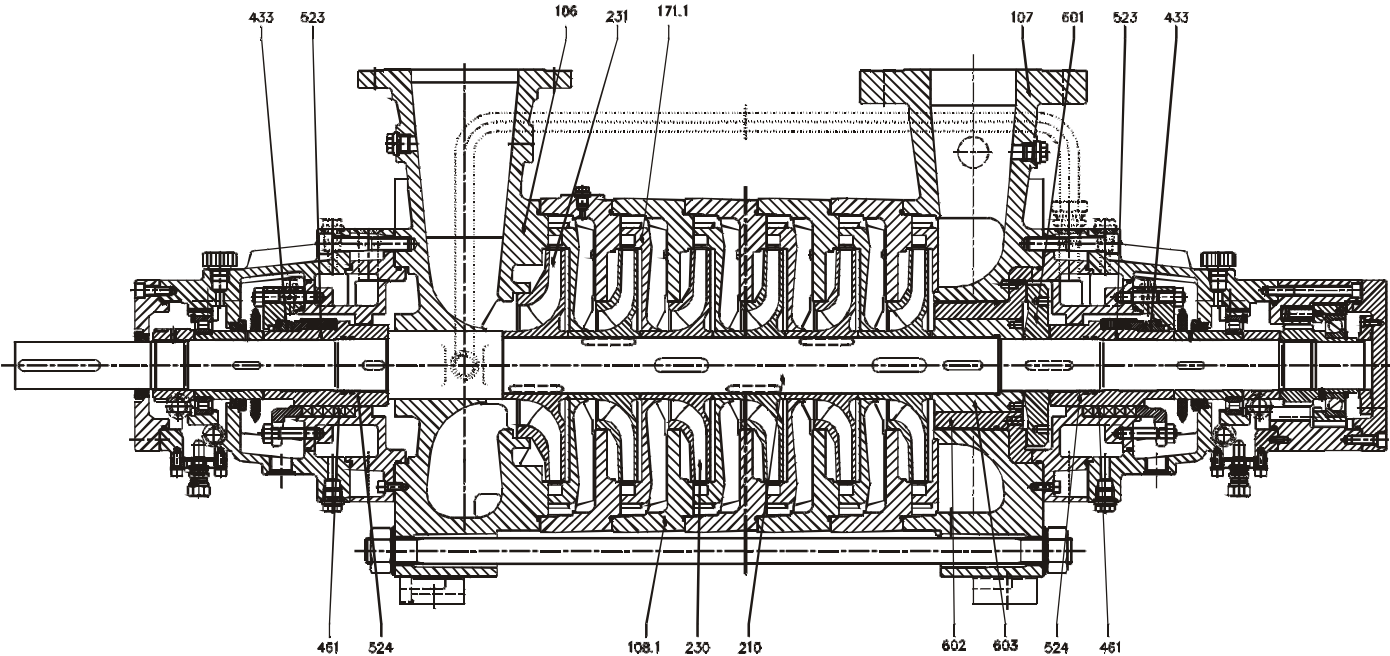

For material of construction please see page 14.

Material design

Pos.	item	Material Code	
		TE	TF
106	Suction casing	1.4008	
107	Discharge casing	1.4008	
108.1	Stage casing	1.4008	
230	Impeller	GG-25 EN-GJL-HB195	1.4409
231	Suction impeller	1.4409	
171.1	Diffusor	GG-25 EN-GJL-HB195	1.4409
210	Shaft	1.4313	
524	Shaft protection sleeve	1.4122	
523	Shaft sleeve	1.4571	
601	Balance disc	1.4034	
602	Balance disc seat	1.4088	
603	Balance drum	1.4034	
433	Mechanical seal	various material options	
461	Packed gland	PTFE / graphite	

Operating limits

Allowable casing pressure

Type MSH with DIN flanges

Size	max. allowable pressure (bar) as function of the liquid temperature ¹⁾ material of construction Chrome steel					
	-10°C bis 120 °C		< 140°C		< 180 °C	
	S	D	S	D	S	D
050						
065	16	160	15,7	159	15,5	158
100						

¹⁾ consider mechanical seal pressure/temperature rating as well

S = Suction casing, D = Discharge casing

Type MSH with ANSI flanges

Size	max. allowable pressure (bar) * as function of the liquid temperature ¹⁾ material of construction Chrome steel					
	-10°C bis 120 °C		< 140°C		< 180 °C	
	S	D	S	D	S	D
050	16	101,9	15,7	100,8	15,5	98,6
065	16	153	15,7	151,4	15,5	147,9
100						

¹⁾ consider mechanical seal pressure/temperature rating as well

* higher allowable pressures as option.

S = Suction casing, D = Discharge casing

Max. permissible speed and permissible number of stages

Type MSH

Size	Hydraulic	max. Speed rpm	max. number of stages
050	A, B	1750	18
		2950	18
		3550	16
065	A, C	1750	18
		2950	18
		3550	14
	B, D	1750	18
		2950	18
		3550	18
100	A, C	1750	15
		2950	14
		3550	9
	B, D	1750	15
		2950	15
		3550	11

Dimensional drawing MSH with axial inlet

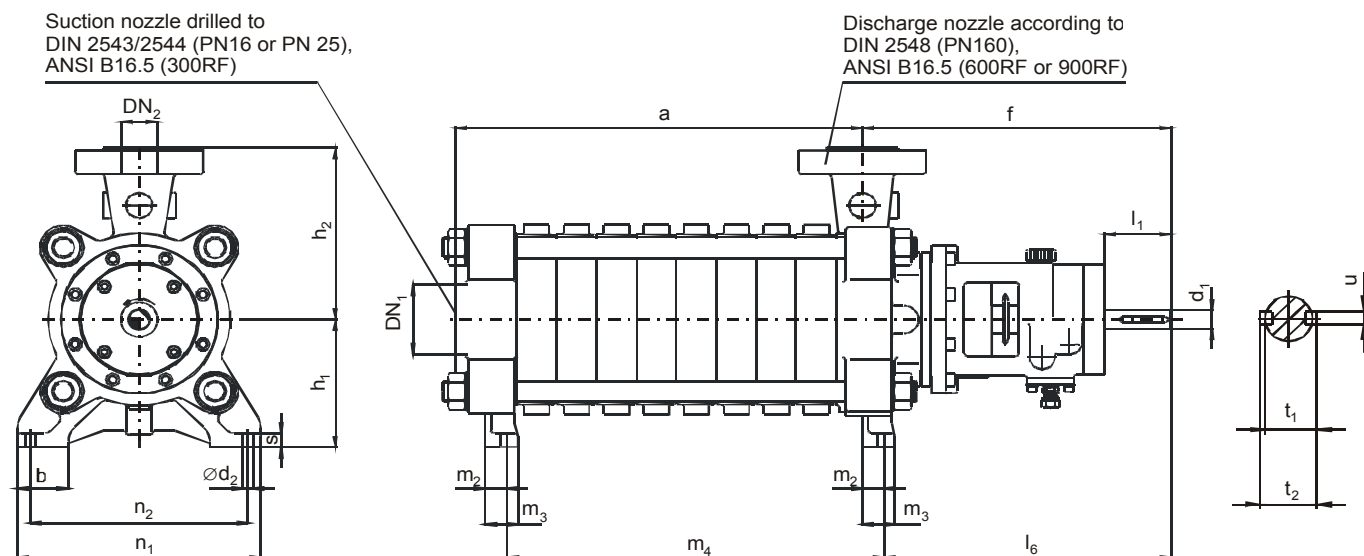

Drawing does not show all possible variants

Arrangement without lift-off device

Dimensions in mm, casing tolerance per DIN 1680 GTB 18/5 to be applied on unmachined parts

Size	DN		Pump dimension			Feet dimension								Shaft end				
	DN ₂	DN ₁	f	h ₁	h ₂	b	s	m ₂	m ₃	n ₁	n ₂	d ₂	l ₆	d ₁ ¹⁾	l ₁	t ₁	t ₂	u
050	050	100	435	185	245	70	20	30	45	335	300	14	405	28	100	29,9	31,8	8
065	065	125	492	255	300	82	30	40	75	380	320	18	462	38	117	40,3	42,6	10
100	100	150	540	280	345	85	30	40	75	380	320	18	500	56	140	58	60	14

Arrangement with lift-off device

Dimensions in mm, casing tolerance per DIN 1680 GTB 18/5 to be applied on unmachined parts

Size	DN		Pump dimension			Feet dimension								Shaft end				
	DN ₂	DN ₁	f	h ₁	h ₂	b	s	m ₂	m ₃	n ₁	n ₂	d ₂	l ₆	d ₁ ¹⁾	l ₁	t ₁	t ₂	u
050	050	100	525	185	245	70	20	30	45	335	300	14	495	28	100	29,9	31,8	8
065	065	125	582	255	300	82	30	40	75	380	320	18	552	38	117	40,3	42,6	10
100	100	150	625	280	345	85	30	40	75	380	320	18	585	56	140	58	60	14

For both arrangements

Dimensions in mm, casing tolerance per DIN 1680 GTB 18/5 to be applied on unmachined parts

Size	050		065		100	
	a	m ₄	a	m ₄	a	m ₄
2	175	135	260	210	315	280
3	230	190	330	280	400	365
4	285	245	400	350	485	450
5	340	300	470	420	570	535
6	395	355	540	490	655	620
7	450	410	610	560	740	705
8	505	465	680	630	825	790
9	560	520	750	700	910	875
10	615	575	820	770	995	960
11	670	630	890	840	1080	1045
12	725	685	960	910	1165	1130
13	780	740	1030	980	1250	1215
14	835	795	1100	1050	1335	1300
15	890	850	1170	1120	1420	1385
16	945	905	1240	1190	1505	1470
17	1000	960	1310	1260	1590	1555
18	1055	1015	1380	1330	1675	1640

¹⁾ k6 - tolerance fit

Dimensional drawing MSH with radial inlet

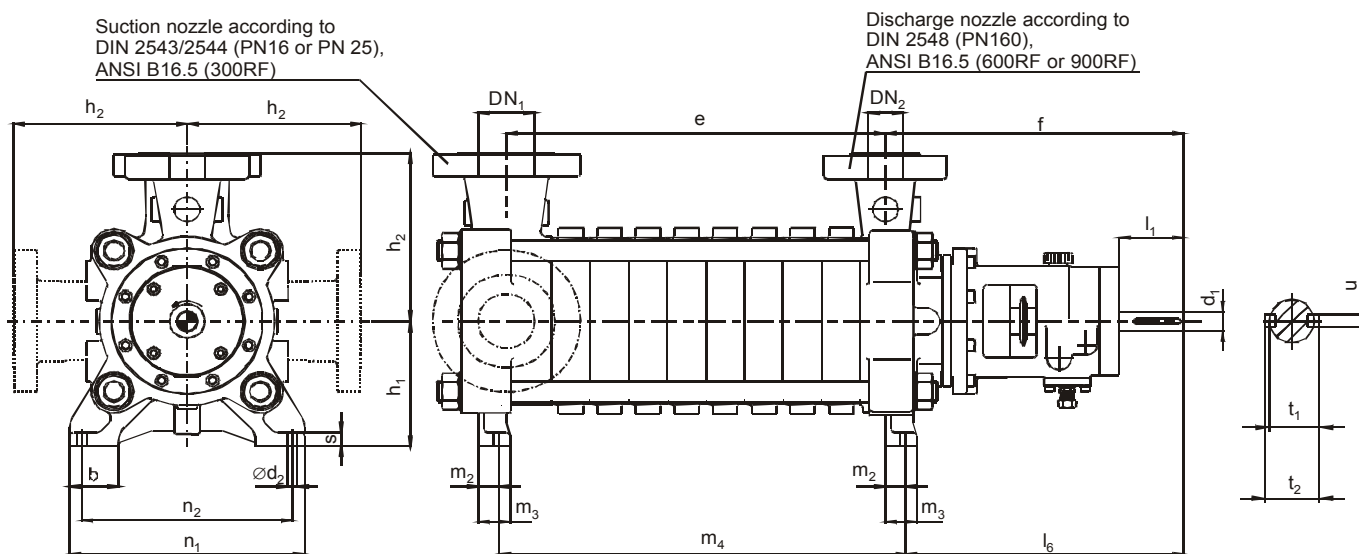

Drawing does not show all possible variants

Arrangement without lift-off device

Dimensions in mm, casing tolerance per DIN 1680 GTB 18/5 to be applied on unmachined parts

Size	DN ₂	DN ₁	Pump dimension			Feet dimension								Shaft end				
			f	h ₁	h ₂	b	s	m ₂	m ₃	n ₁	n ₂	d ₂	l ₆	d ₁ ¹⁾	l ₁	t ₁	t ₂	u
050	050	080	435	185	245	70	20	30	45	335	300	14	405	28	100	29,9	31,8	8
065	065	100	492	255	300	82	30	40	75	380	320	18	462	38	117	40,3	42,6	10
100	100	125	540	280	345	85	30	40	75	380	320	18	500	56	140	58	60	14

Arrangement with lift-off device

Dimensions in mm, casing tolerance per DIN 1680 GTB 18/5 to be applied on unmachined parts

Size	DN ₂	DN ₁	Pump dimension			Feet dimension								Shaft end				
			f	h ₁	h ₂	b	s	m ₂	m ₃	n ₁	n ₂	d ₂	l ₆	d ₁ ¹⁾	l ₁	t ₁	t ₂	u
050	050	080	525	185	245	70	20	30	45	335	300	14	495	28	100	29,9	31,8	8
065	065	100	582	255	300	82	30	40	75	380	320	18	552	38	117	40,3	42,6	10
100	100	125	625	280	345	85	30	40	75	380	320	18	585	56	140	58	60	14

For both arrangements

Dimensions in mm, casing tolerance per DIN 1680 GTB 18/5 to be applied on unmachined parts

Size	050		065		100	
	e	m ₄	e	m ₄	e	m ₄
2 ²⁾	155	195	200	260	255	330
3	210	250	270	330	340	415
4	265	305	340	400	425	500
5	320	360	410	470	510	585
6	375	415	480	540	595	670
7	430	470	550	610	680	755
8	485	525	620	680	765	840
9	540	580	690	750	850	925
10	595	635	760	820	935	1010
11	650	690	830	890	1020	1095
12	705	745	900	960	1105	1180
13	760	800	970	1030	1190	1265
14	815	855	1040	1100	1275	1350
15	870	910	1110	1170	1360	1435
16	925	965	1180	1240	1445	1520
17	980	1020	1250	1310	1530	1605
18	1035	1075	1320	1380	1615	1690

¹⁾ k6 - tolerance fit

²⁾ Suction casing radial top only possible with 3 or more stages

Dimension drawing MSH with inboard and outboard anti-friction bearing

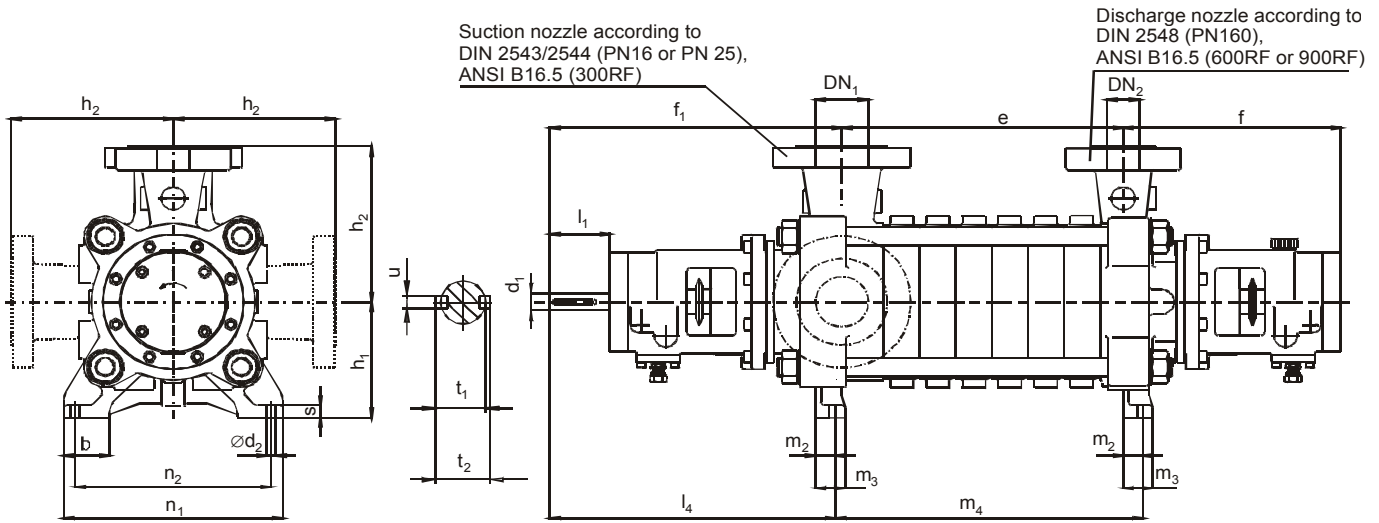

Drawing does not show all possible variants

Arrangement without lift-off device

Dimensions in mm, casing tolerance per DIN 1680 GTB 18/5 to be applied on unmachined parts

Size	DN		Pump dimension				Feet dimension								Shaft end				
	DN ₂	DN ₁	f	f ₁	h ₁	h ₂	b	s	m ₂	m ₃	n ₁	n ₂	d ₂	l ₄	d ₁ ¹⁾	l ₁	t ₁	t ₂	u
050	050	080	332	445	185	245	70	20	30	45	335	300	14	435	28	100	29,9	31,8	8
065	065	100	374	488	255	300	82	30	40	75	380	320	18	458	38	117	40,3	42,6	10
100	100	125	386	526	280	345	85	30	40	75	380	320	18	490	56	140	58	60	14

Arrangement with lift-off device

Dimensions in mm, casing tolerance per DIN 1680 GTB 18/5 to be applied on unmachined parts

Size	DN		Pump dimension				Feet dimension								Shaft end				
	DN ₂	DN ₁	f	f ₁	h ₁	h ₂	b	s	m ₂	m ₃	n ₁	n ₂	d ₂	l ₄	d ₁ ¹⁾	l ₁	t ₁	t ₂	u
050	050	080	425	445	185	245	70	20	30	45	335	300	14	435	28	100	29,9	31,8	8
065	065	100	464	488	255	300	82	30	40	75	380	320	18	458	38	117	40,3	42,6	10
100	100	125	484	526	280	345	85	30	40	75	380	320	18	490	56	140	58	60	14

For both arrangements

Dimensions in mm, casing tolerance per DIN 1680 GTB 18/5 to be applied on unmachined parts

Size	050		065		100	
	e	m ₄	e	m ₄	e	m ₄
2 ²⁾	155	195	200	260	255	330
3	210	250	270	330	340	415
4	265	305	340	400	425	500
5	320	360	410	470	510	585
6	375	415	480	540	595	670
7	430	470	550	610	680	755
8	485	525	620	680	765	840
9	540	580	690	750	850	925
10	595	635	760	820	935	1010
11	650	690	830	890	1020	1095
12	705	745	900	960	1105	1180
13	760	800	970	1030	1190	1265
14	815	855	1040	1100	1275	1350
15	870	910	1110	1170	1360	1435
16	925	965	1180	1240	1445	1520
17	980	1020	1250	1310	1530	1605
18	1035	1075	1320	1380	1615	1690

¹⁾ k6 - tolerance fit

²⁾ Suction casing radial top only possible with 3 or more stages

Connections

MSH with axial inlet

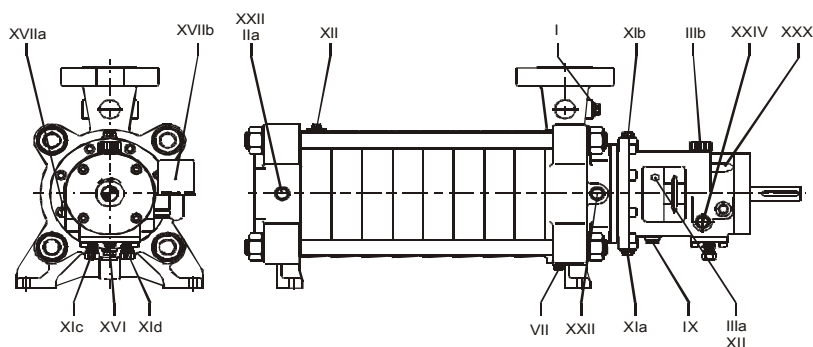

MSH with radial inlet

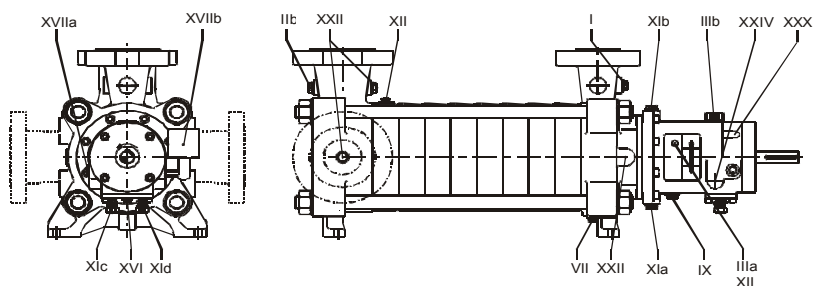

MSH with inboard and outboard anti-friction bearing

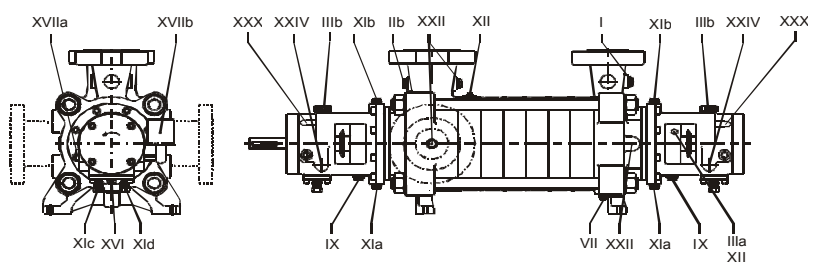

Pos.	Connection	Size dimension	
		050	065-100
I ¹⁾	Pressure gauge	G1/2	G1/2
IIa ¹⁾	Pressure gauge	G1/2	G3/4
IIb ¹⁾	Pressure gauge	G1/2	G1/2
IIIa	Vent mechanical seal	G1/4	G1/4
IIIb	Vent bearing	G1/2	G1/2
VII ¹⁾	Drain	G1/4	G1/2
IX ¹⁾	Leck outlet	G3/8	G3/4
XIa	Cooling Inlet seal chamber	G3/8	G1/2
XIb	Cooling outlet seal chamber	G3/8	G1/2
XIc	Cooling inlet bearing	Pipe Ø 12	Pipe Ø 12
XId	Cooling outlet bearing	Pipe Ø 12	Pipe Ø 12
XII	Connection for circulation	G1/4	G1/4
XVI ¹⁾	Oil outlet	G3/8	G3/8
XVIIa	Constant level oiler	G1/2	G1/2
XVIIb	Constant level oiler	G1/4	G1/4
XXII	Connection for balancing flow	G1/2	G3/4
XXIV ¹⁾	Connection for thermometer	G1/2	G1/2
XXX	Thrust impuls measuring possible		

1) tapped and plugged

Material Description

Material-No.	Manufacturing standard			equivalent or comparable standard				components
	DIN-material code old	DIN-material code new	EN-designation	US-material code		ISO	Japan JIS	
				ASTM-Standards	UNS			
EN-JL 2030	GG-25	EN-GJL-HB 195	EN-GJL-HB 195	A 48 Class 25/30	F 11701/F 12101	185/Gr. 30	G 5501, FC 250/300	Impeller/Diffuser
1.4008	G-X8CrNi 13	G-X7CrNiMo 12-1	G-X7CrNiMo 12-1	A 217 Gr. CA 15	J 91 150		G 5121, C1 SCS 1	Casing
1.4034	X46Cr13	X46Cr13	X46Cr13					Balance Disc, Balance Drum
1.4088	G-X170Cr18							Balance Disc Seal
1.4122	X35CrMo 17	X39CrMo 17-1	X39CrMo 17-1					Shaft Wearing Sleeve
1.4313	G-X5CrNi13-4	X3CrNiMo13-4	X3CrNiMo13-4	CA6-NM			SCS5, SCS6	Shaft
1.4409	G-X2CrNiMo 18 10	G-X2CrNiMo 19-11	G-X2CrNiMo 19-11	A 351, 744 Gr. CF 3M	J 92 800	683-13-9	G 5121,C1 SCS I44 02	Impeller/Diffuser
1.4571	X6CrNiMoTi 17 12	X6CrNiMoTi 17-12-2	X6CrNiMoTi 17-12-2	193 Gr. B 8 M	S 31 600	683-1-21	G 4303,GrI SUS 316	Shaft Sleeve

Materials are produced to EN/DIN specifications. For other equivalent or comparable standards are mentioned only for information.

ASTM American Society for Testing and Materials
 DIN Deutsches Institut für Normung e.V.
 EN European Standard
 ISO International Standardisation Organisation
 UNS Unified Numbering System (USA)

Sterling SIHI GmbH
Werk Ludwigshafen
 Halbergstr. 1, 67061 Ludwigshafen, Germany
 Telefon (0621) 56 12 - 0 Telefax (0621) 56 12 - 209