

Dosing units and -systems	Chapter 1
Dosing- and feeding pumps	Chapter 2
Fittings	Chapter 3
Connection pieces and dosing hoses	Chapter 4
General informations Usage of catalogue / order system, resistance chart, installation examples, product-documentation, certificates	Chapter 5

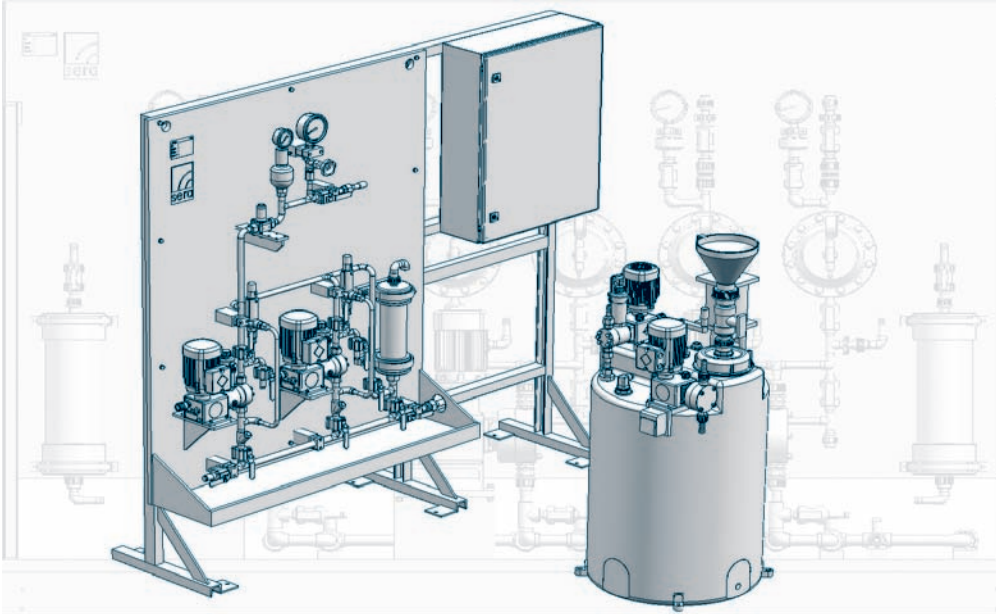

Dosing units and -systems for...

- Environmental Technology
- Domestic Technique
- Sewage Treatment Plants
- Waterworks
- Power Plants
- Beverage -/ Food Industry
- Chemical Industry
- Paper Industry
- Sugar Industry
- Textile Industry
- Petrochemistry
- Agriculture
- Mechanical Engineering

as well as all other sectors dealing with the storage, feeding and dosing of liquid chemicals.

Dosing units and -systems		Product range	Page
Preparation units	for polymer solutions	1-Chamber-units 2-Chamber-units 3-Chamber-units	1.2
	for Suspensions (e.g. lime milk, calcium sulphate, activated carbon, a.o.)		see Industrial solutions
	for chemical solutions	HY-DA AN-DA	1.8
Dosing-, transfusing- and storage units for liquid chemicals	Vertical construction (f. wall mounting)	DAV	1.12
	Horizontal construction (f. ground erection)		see industrial solutions
Dosing systems	for disinfection	ClO ₂ - units PDS	1.16
	for coloration and mixing	KKV-Dosing system	1.20
	for mobile usage	DG - Series MDG - Series	1.22
Packaged units	for the storage and dosing of different chemical solutions	KDO	1.26
Industrial solutions	Examples of different dosing units in industrial specific designs		1.29
Accessories for dosing units	tanks, agitators, absorber, measuring instruments, control units, dry feeders		1.39

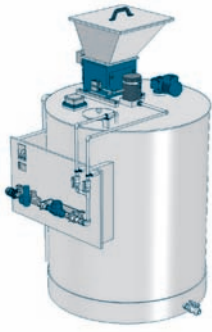

PLA-1 V-... in survey

- fully automatic preparation of organic flocculent aid (pulverized and/or liquid)
- Programmable control (PLC)
- Selectable concentration of ready solution
- Feeding device
- Volumetric metering screw with thermic protection zone
- Concentrate pump (option)
- Dissolving water installation
- Electric agitator
- Performance graduation that meets the requirements

Infobox

Order information [Page 1.3](#)
Options/Accessories [Page 1.3](#)

Resistance chart [Chapter 5](#)
Installation examples [Chapter 5](#)

Technical data

Type	Max. deposit capacity in l/h at 60 min. maturing time	Power consumption approx. kW	Weight (empty) approx. kg
PLA-1V-500.1	500	1,0	200
PLA-1V-1000.1	1000	1,3	215

Dimensional drawing

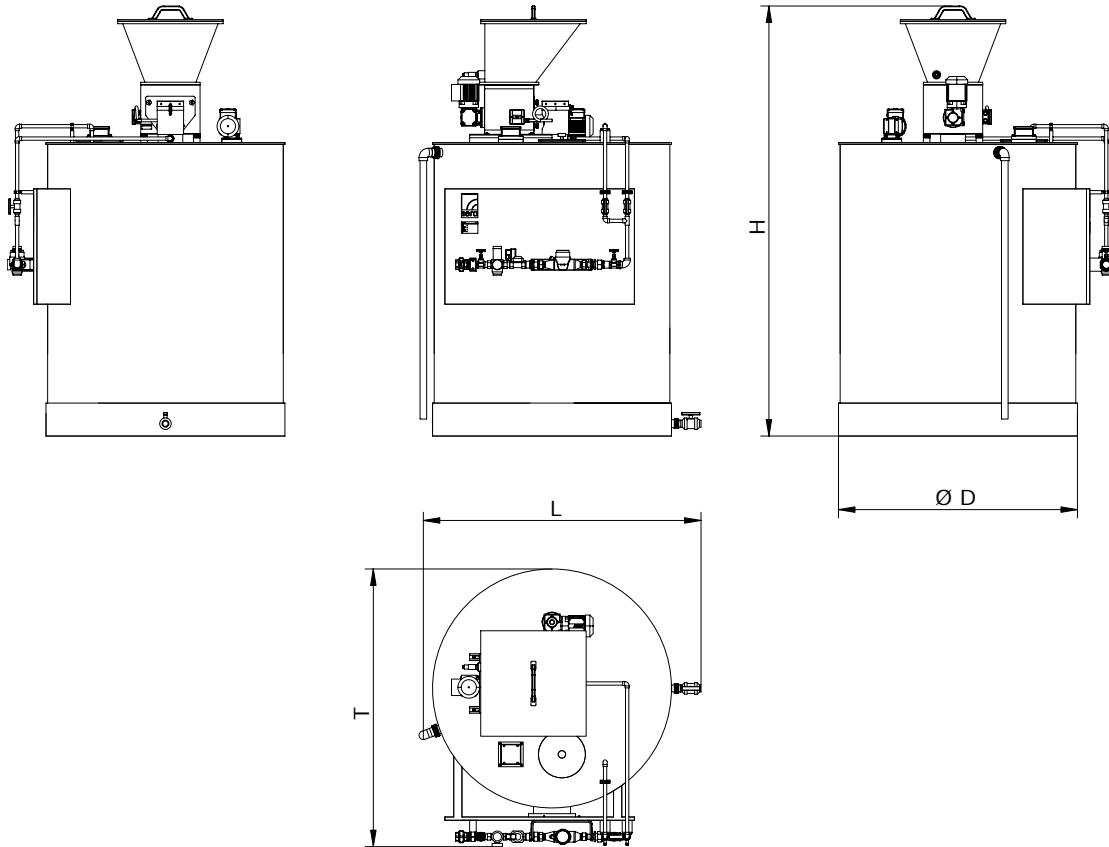

Dimensional chart
all indications in mm

Type	D	L	T	H	Connections		
					Dissolving water	Removal	Draining
PLA-1V-500.1	1100	ca. 1470	ca. 1340	1700	Rp 1/2 ... Rp 1	DN 15 ... DN 25	DN 25
PLA-1V-1000.1	1500	ca. 1870	ca. 1740	1800	Rp 1/2 ... Rp 1	DN 15 ... DN 25	DN 25

Elektrical data (standard-design)

Type	Supply voltage	Control voltage	Enlosure	
			Control cabinet	Elektrical consumers
PLA-1V-...	3 / 400 V / Hz + N + PE	24 V DC	IP 54	IP 55

Order information

Basic design

PLA-1V-...

- 1-chamber tank made of PP
- Volumetric metering screw (VDS) with hopper, 60 litres
- Signal „hopper empty“
- Feeding device
- 1 electric agitator (low-speed)
- Level monitoring
- Dissolving water installation
- Control (PLC) fully automatic preparation
- Language on display de/en

Type	x
PLA-1V-500.1	
PLA-1V-1000.1	

Options/Accessories		x
Top for storage hopper, 40 Liter	max. 2 additional tops possible	▲
Outer vibrator + vibration damper for VDS		▲
Dosing pump incl. accessories f. fluid concentrate		▲
After-dilution station	Dilution of the preparation in a ratio of 1:10	▲
Level indicator (for tank-niveau)	mounted to tank	▲
Small feeding device		▲
mounted dosing unities		▲
Special voltage	for control and other electrical consumers	▲
BUS-Connection	PROFIBUS DP / Slave	▲
	Ind. Ethernet	▲
Control panel	Control panel TOUCH Display with Touchscreen	▲
	Language other languages possible	▲
<p>● = Basic design – = not available ▲ = with add. price ☉ = on request ○ = without add. price Art.-No. = available in basic design/ accessories</p>		

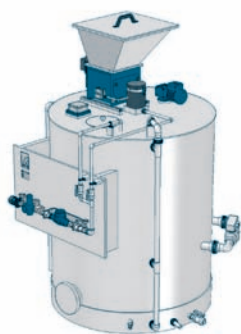

PLA-2V... in survey

- fully automatic preparation of organic flocculent aid (pulverized and/or liquid)
- Programmable control (PLC)
- Selectable concentration of ready solution
- Volumetric metering screw with thermic protection zone
- Feeding device
- Concentrate pump (option)
- Dissolving water installation
- Electric agitator
- Performance graduation that meets the requirements

Infobox

- Order information [Page 1.5](#)
- Options/Accessories [Page 1.5](#)
- Resistance chart [Chapter 5](#)
- Installation examples [Chapter 5](#)

Technical data

Type	Max. deposit capacity l/h at 60 min. maturing time	Power consumption approx. kW	Weight (empty) approx. kg
PLA - 2V - 200.1	200	0,8	ca. 175
PLA - 2V - 400.1	400	1,0	ca. 220
PLA - 2V - 1000.1	1000	1,3	ca. 285

Dimensional drawing

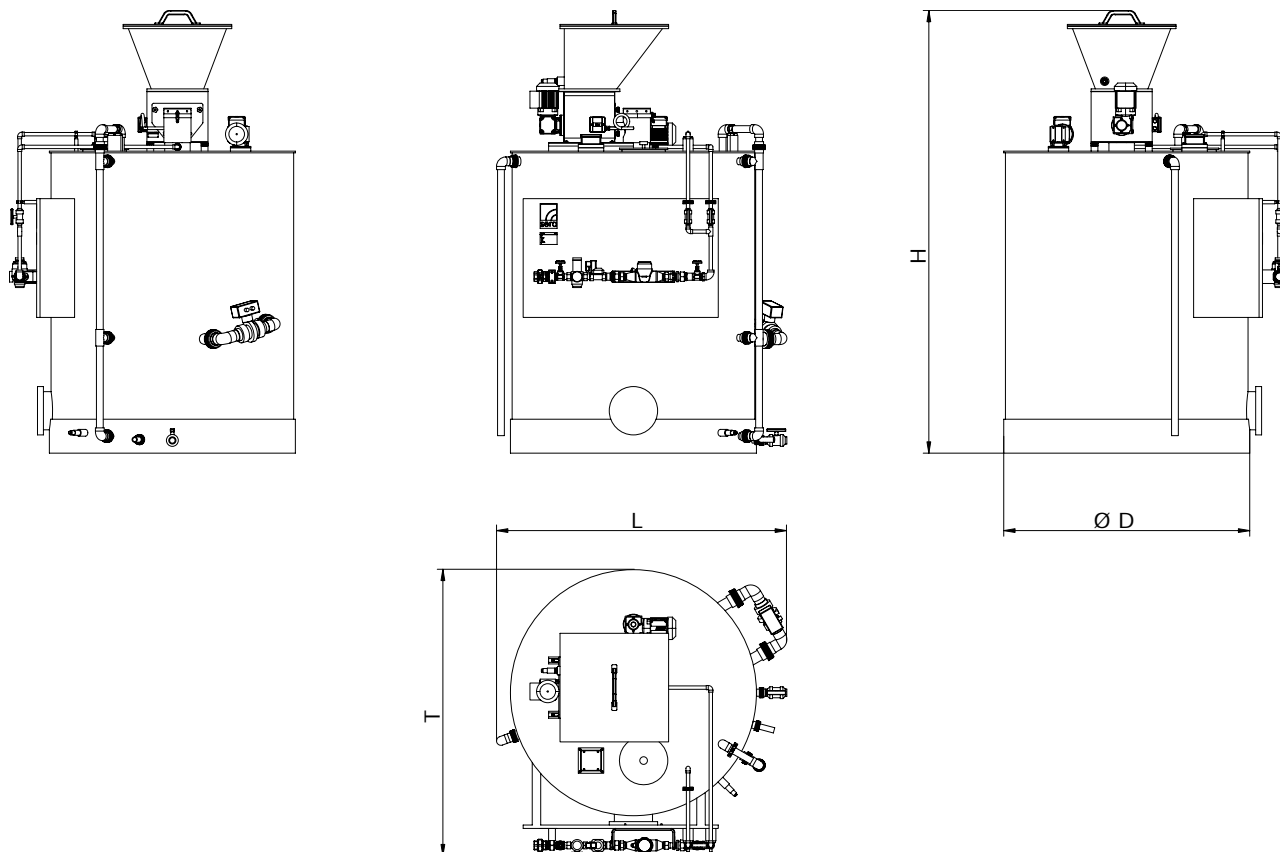

Dimensional chart

All indications in mm

Type	appr. D	appr. L	appr. T	appr. H	Connections		
					Dissolving water	Removal	Draining
PLA - 2V - 200.1	900	1100	1300	2150	Rp 1/2 ... Rp 1	DN 15 .. DN 25	DN 25
PLA - 2V - 400.1	1500	1850	1800	2050	Rp 1/2 ... Rp 1	DN 15 .. DN 25	DN 25
PLA - 2V - 1000.1	1500	1850	1800	2650	Rp 1/2 ... Rp 1	DN 15 .. DN 25	DN 25

Elektrical data (standard-design)

Type	Supply voltage	Control voltage	Enclosure	
			Control cabinet	electrical consumers
PLA - 2V - ...	3 / 400 V / Hz + N + PE	24 V DC	IP 54	IP 55

Order information

Basic design

PLA - 2V -...

- 2-chamber tank made of PP
- Volumetric metering screw (VDS) with hopper, 60 litres
- Signal „hopper empty“
- Feeding device
- 1 electric agitator (low-speed)
- Level monitoring
- Dissolving water installation
- Control (PLC) fully automatic preparation
- Language on display de/en

Type	x
PLA - 2V - 200.1	
PLA - 2V - 500.1	
PLA - 2V - 1000.1	

Options/Accessories			x
Top for storage hopper, 40 litres	max. 2 additional tops possible	▲	
Outer vibrator + vibration damper for VDS		▲	
Dosing pump incl. accessories f. fluid concentrate		▲	
After-dilution station	Dilution of the preparation in a ratio of 1:10	▲	
Small feeding device		▲	
mounted dosing unities		▲	
Special voltage	for control and other electrical consumers	▲	
BUS-Connection	PROFIBUS DP / Slave	▲	
	Ind. Ethernet	▲	
Control panel	Control panel TOUCH	▲	Display with Touchscreen
	Language	▲	other languages possible
<p>● = Basic design -- = not available ▲ = with add. price ⊗ = on request ○ = without add. price Art.-No. = available in basic design/ accessories</p>			

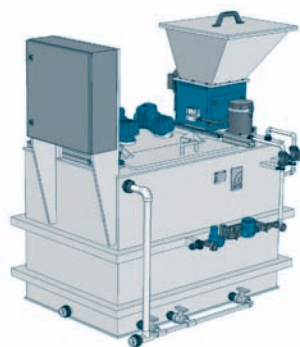

PLA-3H-... in survey

- fully automatic preparation of organic flocculent aid (pulverized and/or liquid)
- Programmable control (SPS)
- Selectable concentration of ready solution
- Feeding device
- Volumetric metering screw (VDS) with thermic protection zone
- Concentrate pump (optional)
- Dissolving water installation
- 2 electric agitators (3. agitator, option)
- Performance graduation that meets the requirements

Infobox

- Order information [Page 1.7](#)
- Options/Accessories [Page 1.7](#)
- Resistance chart [Chapter 5](#)
- Installation examples [Chapter 5](#)

Technical data

Type	Max. deposit capacity in l/h at 60 min. maturing time	Power consumption (approx.) kW		Weight (empty) approx. kg
		2 agitators	3 agitators	
PLA-3H-500.1	500	1,0	1,2	200
PLA-3H-1000.1	1000	1,2	1,5	250
PLA-3H-2000.1	2000	1,4	1,8	320
PLA-3H-3000.1	3000	1,8	2,4	400
PLA-3H-4000.1	4000	2,2	3,0	500

Dimensional drawing

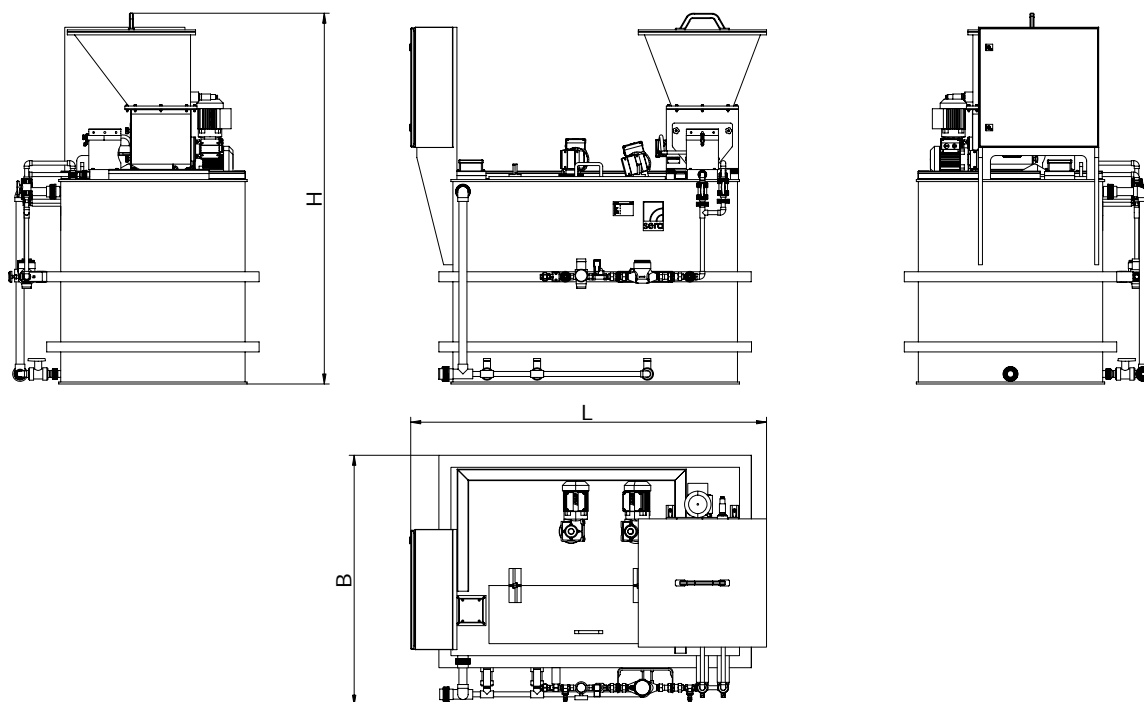

Dimensional chart

All indications in mm

Type	L	B	H	Connections		
				Dissolving water	Removal	Draining
PLA-3H-500.1	1800	1100	1600	G 1/2	G 1	G 1 1/4
PLA-3H-1000.1	1900	1250	1900	G 3/4	G 1 1/2	G 1 1/4
PLA-3H-2000.1	2200	1500	2100	G 1	G 2	G 1 1/4
PLA-3H-3000.1	2900	1500	2100	G 1 1/4	G 2	G 1 1/4
PLA-3H-4000.1	3100	1800	2100	G 1 1/2	G 2 1/4	G 1 1/4

Elektrical data (standard-design)

Type	Supply voltage	Control voltage	Enclosure	
			Control cabinet	electrical consumers
PLA-3H-...	3 / 400 V / Hz + N + PE	24 V DC	IP 54	IP 55

Order information

Basic design

PLA-3H-...

- 3-chamber tank made of PP
- Volumetric metering screw (VDS) with hopper, 60 litres
- Signal „hopper empty“
- Feeding device
- 2 electric agitators (low-speed)
- Level monitoring
- Dissolving water installation
- Control (PLC) fully automatic preparation
- Language on display de/en

Type	x
PLA-3H-500.1	
PLA-3H-1000.1	
PLA-3H-2000.1	
PLA-3H-3000.1	
PLA-3H-4000.1	

Options/Accessories		x
Top for storage hopper, 40 litres	max. 2 additional tops possible	▲
Outer vibrator + vibration damper for VDS		▲
Dosing pump incl. accessories f. fluid concentrate		▲
3rd agitator		▲
After-dilution station	Dilution of the preparation in a ratio of 1:10	▲
Small feeding device		▲
mounted dosing unities		▲
Special voltage	for control and other electrical consumers	▲
BUS-Connection	PROFIBUS DP / Slave	▲
	Ind. Ethernet	▲
Control panel	Control panel TOUCH Display with Touchscreen	▲
	Language other languages possible	▲

● = Basic design – = not available ▲ = with add. price ☉ = on request ○ = without add. price Art.-No. = available in basic design/ accessories

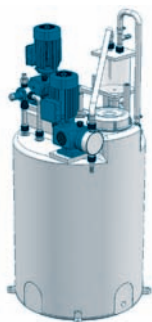

HY-DA in survey

- Complete dosing system
- Compact design
- User-friendly
- No deleterious emissions
- High dosing accuracy
- Low maintenance
- High lifetime
- Simple integration in existing water/steam cycles

Infobox

- Order information [Page 1.9](#)
- Options/Accessories [Page 1.9](#)
- Resistance chart [Chapter 5](#)
- Installation examples [Chapter 5](#)

Technical data

Type	Tank volume	Conveying capacity	max. permissible counter pressure	Weight (empty) approx. kg
	Litre	Litres/hour		
HY - DA 200 - 3,75	200	3,75	10	49
HY - DA 200 - 7,5	200	7,5	10	49
HY - DA 200 - 18	200	18	10	54
HY - DA 200 - 25	200	25	10	54
HY - DA 200 - 50	200	50	10	54
HY - DA 200 - 75	200	75	10	55

Dimensional drawing

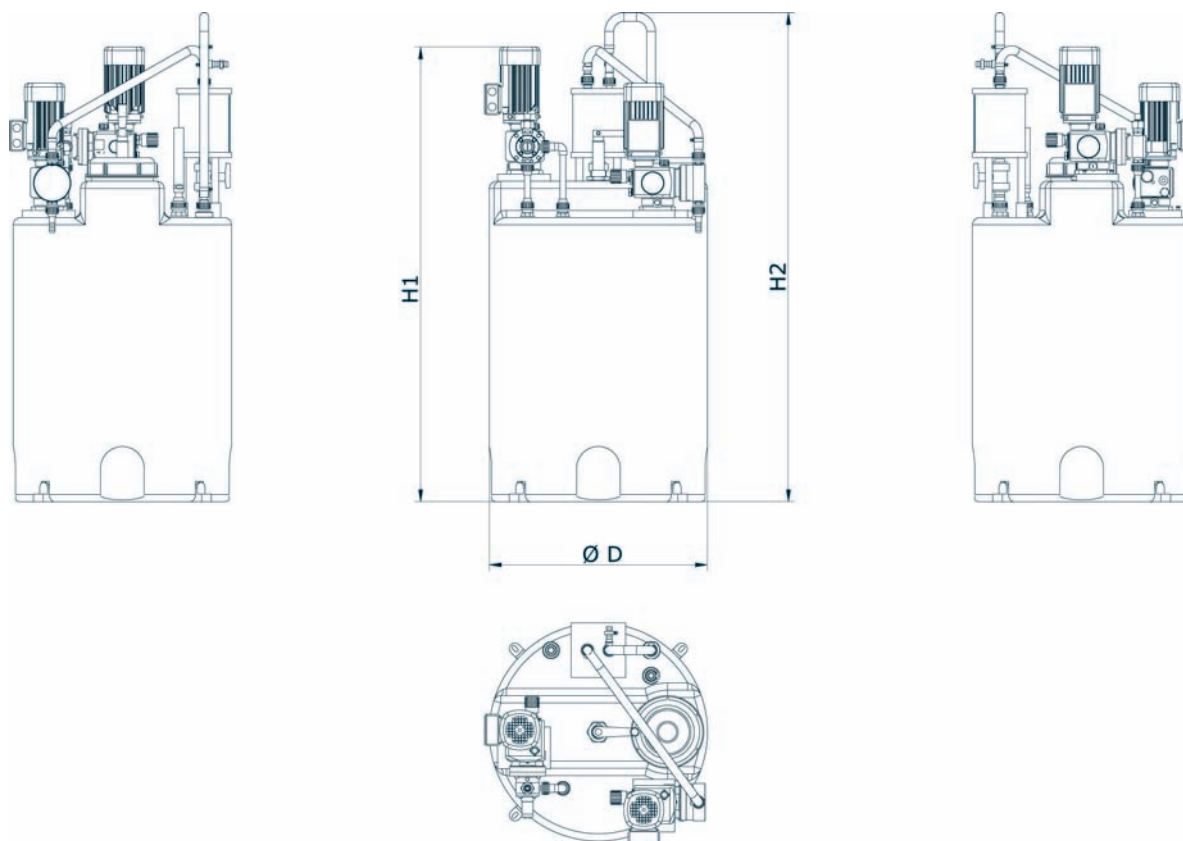

Dimensional chart

All indications in mm

Type	D	H1	H2	Process connections	
				Thinning water	Pressure line
HY - DA 200 - 3,75	600	1250	ca. 1400	Insert PVC, d=20	G 3/4
HY - DA 200 - 7,5	600	1250	ca. 1400	Insert PVC, d=20	G 3/4
HY - DA 200 - 18	600	1250	ca. 1400	Insert PVC, d=20	G 3/4
HY - DA 200 - 25	600	1250	ca. 1400	Insert PVC, d=20	G 3/4
HY - DA 200 - 50	600	1250	ca. 1400	Insert PVC, d=20	G 3/4
HY - DA 200 - 75	600	1250	ca. 1400	Insert PVC, d=20	G 3/4

Order information

Basic design

Preparation- and dosing unit HY-DA

- Dosing tank made of PE-transparent, content 200 litres / DxH: 650x880mm seals EPDM or FPM
- Transfusing pump Type R 409.2-115e
- Tapping coupling with flushing adapter made of 1.4571 (without fig.)
- Manual agitator made of PVC (gas tight) Type HM 200.1 G
- Proportioning vessel made of PVC-transp. Type 8195 (content: 2 litres)
- Dosing pump with integrated relief valve
- Suction lance made of PVC (gas tight)
- Dosing valve Type 691.1 (made of 1.4571)
- Activated carbon filter
- Dosing hoses made of PVC with cross-textile ply
- Connection parts (pressure side) for Dosing pump and -valve

Type	x
HY - DA 200 - 3,75	
HY - DA 200 - 7,5	
HY - DA 200 - 18	
HY - DA 200 - 25	
HY - DA 200 - 50	
HY - DA 200 - 75	

Options/Accessories

HY-DA 500 - ...	Dosing tank made of PE-transparent, content 500 litres, DxH: 790x1180 Proportioning vessel Type 8197, content 10 litres	▲	
Enlargement of the unit for combination Hydrazine / ammonia preparation	additional 3-way-ball cock, suction lance and hose	▲	
Absorption vessel with integrated wall mounting	Content 20 litres Material: PE/EPDM	▲	
Electric agitator	Type SM4 incl. sealing flange	▲	
mounted ON/OFF-switch for transfusing pump		▲	
Collecting basin		▲	

Preparation- and dosing units with piston-diaphragm pumps up to 50 bar or piston pumps up to 140 bar on request

● = Basic design – = not available ▲ = with add. price ⊗ = on request ○ = without add. price Art.-No. = available in basic design/ accessories

AN-DA ...

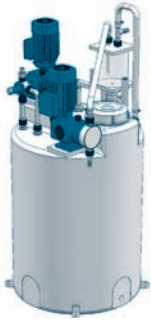

AN-DA in survey

- Complete dosing system
- Compact design
- User-friendly
- No deleterious emissions
- High dosing accuracy
- Low maintenance
- High lifetime
- Simple integration in existing systems

Infobox

Order information [Page 1.11](#)
Options/Accessories [Page 1.11](#)

Resistance chart [Chapter 5](#)
Installation examples [Chapter 5](#)

Technical Data

Type	Tank capacity	Conveying capacity	max. permissible counterpressure bar	Weight (empty) approx. kg
	l litres	litres/hour		
AN - DA 200 - 3,75	200	3,75	10	49
AN - DA 200 - 7,5	200	7,5	10	49
AN - DA 200 - 18	200	18	10	54
AN - DA 200 - 25	200	25	10	54
AN - DA 200 - 50	200	50	10	54
AN - DA 200 - 75	200	75	10	55

Dimensional drawing

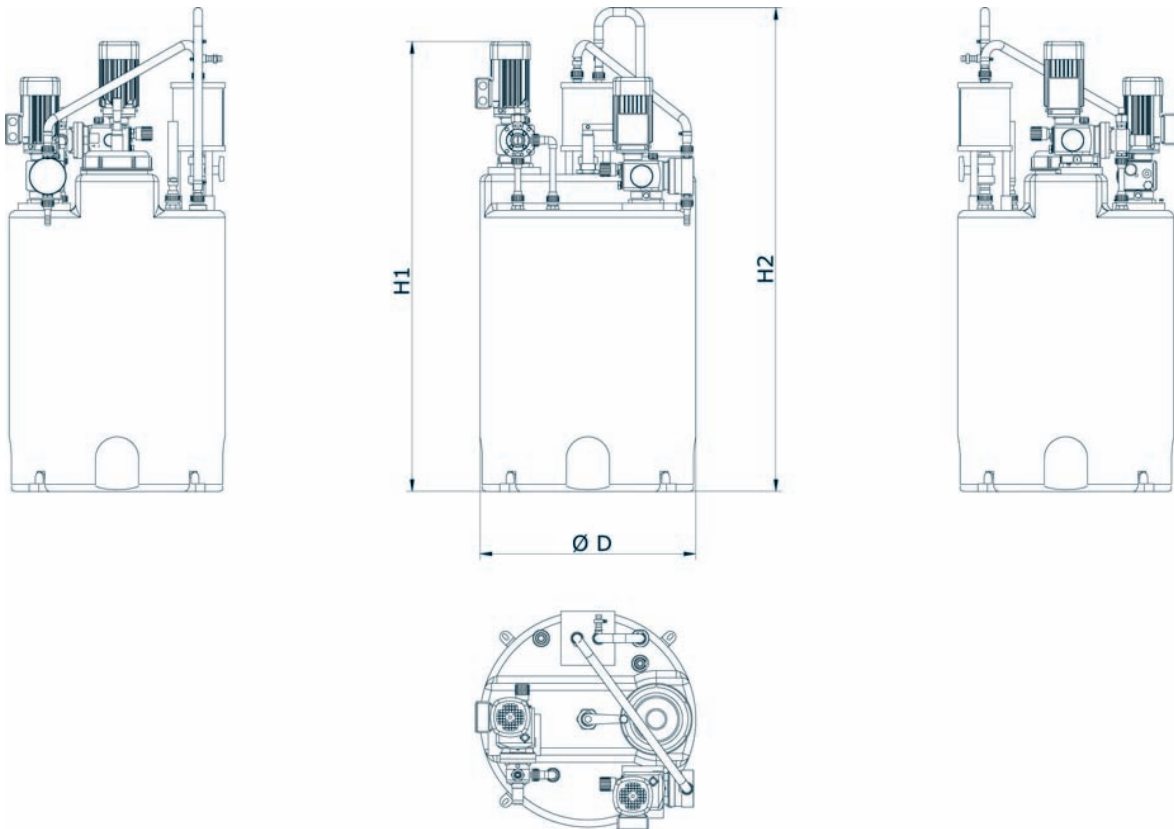

Dimensional chart
All indications in mm

Type	D	H1	H2	Process connections	
				Dilution water	Pressure line
AN - DA 200 - 3,75	600	1250	ca. 1400	Insert PVC, d=20	G 3/4
AN - DA 200 - 7,5	600	1250	ca. 1400	Insert PVC, d=20	G 3/4
AN - DA 200 - 18	600	1250	ca. 1400	Insert PVC, d=20	G 3/4
AN - DA 200 - 25	600	1250	ca. 1400	Insert PVC, d=20	G 3/4
AN - DA 200 - 50	600	1250	ca. 1400	Insert PVC, d=20	G 3/4
AN - DA 200 - 75	600	1250	ca. 1400	Insert PVC, d=20	G 3/4

Order information

Basic design

Preparation- and dosing unit AN-DA

- Dosing tank made of PE-transparent, content 200 litres / DxH: 650x880mm seals EPDM or FPM
- Transfusing pump
Type R 409.2-115e
- Manual agitator made of PVC (gas tight)
Type HM 200.1 G
- Proportioning vessel made of PVC-transp.
Type 8195 (content: 2 litres)
- Dosing pump
with integrated relief valve
- Suction lance made of PVC (gas tight)
- Dosing hoses made of PVC with cross-textile ply

Type	
AN - DA 200 - 3,75	
AN - DA 200 - 7,5	
AN - DA 200 - 18	
AN - DA 200 - 25	
AN - DA 200 - 50	
AN - DA 200 - 75	

Options/Accessories			
AN-DA 300 - ...	Dosing tank made of PE-Transparent, content 300 litres, DxH: 670x1300 Proportioning vessel Type 8196, content 5 litres	▲	
AN-DA 500 - ...	Dosing tank made of PE-Transparent, content 500 litres, DxH: 790x1180 Proportioning vessel Type 8197, content 10 litres	▲	
mounted ON/OFF-switch for transfusing pump		▲	
Collecting basin		▲	
Preparation- and dosing units with piston-diaphragm pumps up to 50 bar or piston pumps up to 140 bar on request			
<p>● = Basic design – = not available ▲ = with add. price ⊗ = on request ○ = without add. price Art.-No. = available in basic design/ accessories</p>			

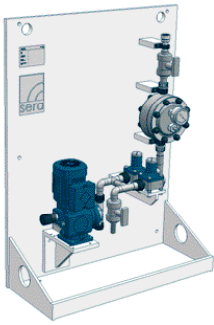

DAV 1 in survey

- The most modern pump technology
- Standardized mounting plates
- Space-saving wall mounting
- Wide application range
- High safety standard
- Large range of capacity
- High dosing accuracy
- Easy to operate
- Low maintenance
- Complete accessory programme

Infobox

Order informations [Page 1.13](#)
Options/Accessories [Page 1.13](#)

Resistance chart [Chapter 5](#)
Installation examples [Chapter 5](#)

Technical data

Type	Conveying capacity	permissible counter-pressure bar	permissible suction height mWC	Quantity pumps	Pump-series
	litres/hour				
DAV 1 - 75.1	up to 75	up to 10	up to 3	1	R/C 204.1-1,2e ... R/C 409.2-75
DAV 1 - 180.1	up to 180	up to 8	up to 3	1	R/C 409.2- 90 ... R/C 409.2-180
DAV 1 - 350.1	up to 350	up to 8	up to 5	1	R/C 409.2-350 ... R/C 409.2-350
DAV 1 - 900.1	up to 900	up to 6	up to 3	1	R 410.2- 450 ... R 410.2- 900
DAV 1 - 1450.1	up to 1450	up to 5	up to 3	1	R 410.2-1100 ... R 410.2-1450

Dimensional drawing for application example

Application example
consisting with following options:

- Diaphragm pulsation damper
- Diaphragm pressure keeping valve
- Drip pan with connection G1

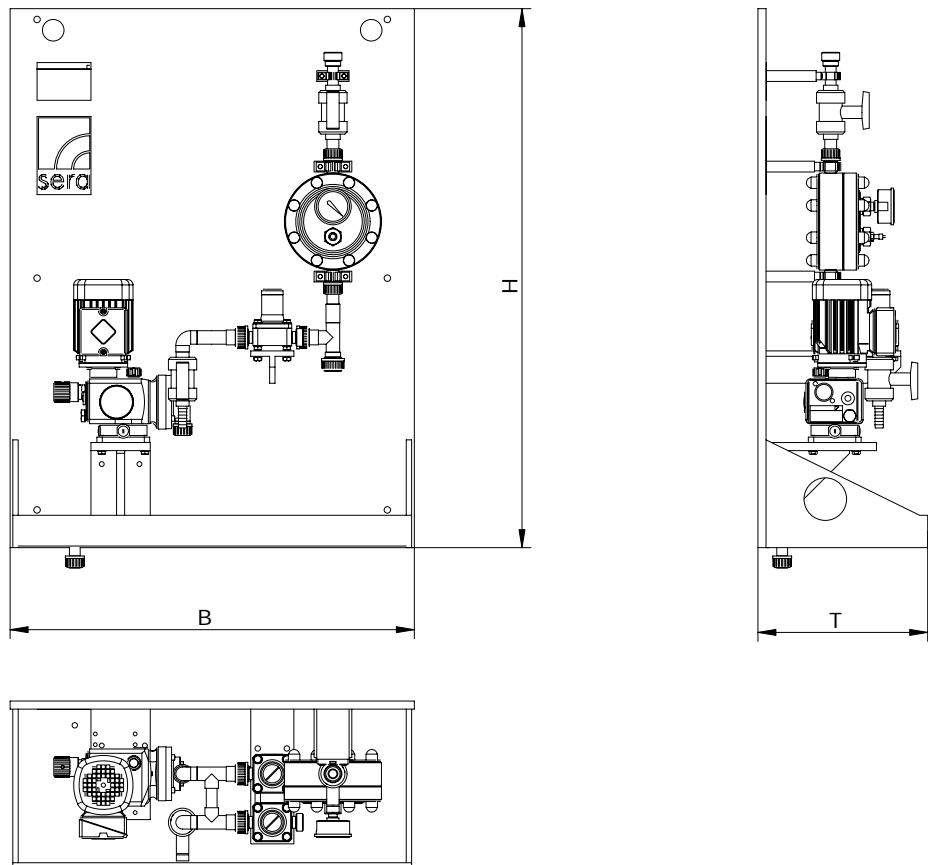

Dimensional chart

All indications in mm

Type	B		T		H	
	Standard-design	Compact-design	Standard-design	Compact-design	Standard-design	Compact-design
DAV 1 - 75.1 ... DAV 1 - 180.1	750	600	315	315	1000	600...1000
DAV 1 - 350.1 ... DAV 1 - 1450.1	1000	750	555	450	1500	750...1000

Order informations

Basic design

DAV 1

- Diaphragm pump
- 2-way-ball cock on suction- and pressure side (shut-off + draining)
- Diaphragm relief valve
- Mounting plates made of PP (without drip pan)
- Line strainer
- Piping made of PVC-U, PP or PVDF
- Seals made of EPDM or FPM

Type	x
DAV 1 - 75.1	
DAV 1 - 180.1	
DAV 1 - 350.1	
DAV 1 - 900.1	
DAV 1 - 1450.1	

Options/Accessories		x
Diaphragm pressure-keeping valve		▲
Pulsation damper	Pulsation damper	▲
	Diaphragm pulsation damper	▲
Drip pan with connection G1 (blind closed)		▲
Drip pan with splash guard with connection G1 (blind closed)	see illustration „Dosing units (e.g. with protection cabinet)“ chapter 1, page 1.36, „Industrial-solutions“	▲
Drain cock (Drip pan)		▲
Flow meter	Magneto-inductive flow meter	▲
	Calorimetric flow controller	▲
	Flow controller (f. pumps of C-series)	▲
Compact-design		▲
further accessories on request		
<p>● = Basic design – = not available ▲ = with add. price ⊗ = on request ○ = without add. price Art.-No. = available in basic design/ accessories</p>		

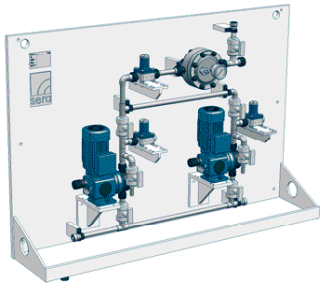

DAV 2 in survey

- The most modern pump technology
- Standardized mounting plates
- Space-saving wall mounting
- Wide application range
- High safety standard
- Large range of capacity
- High dosing accuracy
- Easy to operate
- Low maintenance
- Complete accessory programme

Infobox

Order information [Page 1.15](#)
Options/Accessories [Page 1.15](#)

Resistance chart [Chapter 5](#)
Installation examples [Chapter 5](#)

Technical data

Type	Conveying capacity litres/hour	permissible counterpressure bar	permissible suction height mWC	Quantity pumps	Pump-series
DAV 2 - 75.1	up to 2 x 75	up to 10	up to 3	2	R/C 204.1-1,2e ... R/C 409.2-75
DAV 2 - 180.1	up to 2 x 180	up to 8	up to 3	2	R/C 409.2- 90 ... R/C 409.2-180
DAV 2 - 350.1	up to 2 x 350	up to 8	up to 5	2	R/C 409.2-350 ... R/C 409.2-350
DAV 2 - 900.1	up to 2 x 900	up to 6	up to 3	2	R 410.2- 450 ... R 410.2- 900
DAV 2 - 1450.1	up to 2 x 1450	up to 5	up to 3	2	R 410.2-1100 ... R 410.2-1450

Dimensional drawing for application example

Application example
consisting of basic design
with following options:

- Diaphragm pulsation damper
- Diaphragm pressure-keeping valve
- Drip pan with connection G1

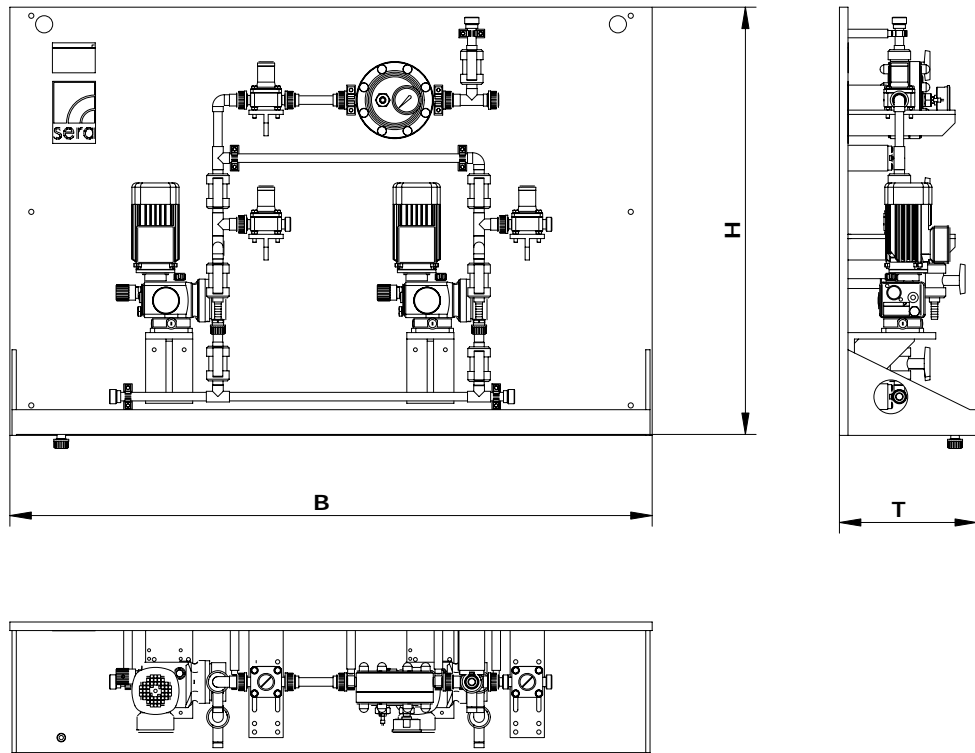

Dimensional chart

All indications in mm

Type	B		T		H	
	Standard-design	Compact-design	Standard-design	Compact-design	Standard-design	Compact-design
DAV 2 - 75.1 ... DAV 2 - 180.1	1500	1000	315	315	1000	750 ... 1000
DAV 2 - 350.1 ... DAV 2 - 1450.1	2000	1250	535	450	1500	750 ... 1000

Order information

Basic design

DAV 2

- 2 diaphragm pumps
- 2-way-ball cocks on suction- and pressure side (shut-off + draining)
- Diaphragm relief valves
- Wandmontageplatte made of PP (without drip pan)
- Line strainer
- Piping made of PVC-U or PP
- Seals made of EPDM or FPM

Type	x
DAV 2 - 75.1	
DAV 2 - 180.1	
DAV 2 - 350.1	
DAV 2 - 900.1	
DAV 2 - 1450.1	

Options/Accessories		x
Diaphragm pressure-keeping valve		▲
Pulsation damper	Pulsation damper	▲
	Diaphragm pulsation damper	▲
Drip pan with connection G1 (blind closed)		▲
Drip pan with splash fuard with connection G1 (blind closed)	see illustration „Dosing units (e.g. with protection cabinet)“ chapter 1, page 1.36, „Industrial-solutions“	▲
Drain cock (drip pan)		▲
Flow meter	Magneto-inductive flow meter	▲
	Calorimetric flow controller	▲
	Flow controller (f. pumps of C-series)	▲
Compact-design		▲
further options/accessories on request		
<p>● = Basic design – = not available ▲ = with add. price ⊙ = on request ○ = without add. price Art.-No. = available in basic design/ accessories</p>		

CDG...



CDG in survey

- Fully automatic production of 2-percent ClO₂ with help of modern control and pump technology
- Highest accuracy
- Excellent efficiency factor
- High reliability
- Easy to operate
- Space saving construction for wall fastening
- Qualified for industrial use
- Practice-oriented capacity grading
- Complete accessories program

Infobox

- Order information [Page 1.17](#)
- Options/Accessories [Page 1.17](#)
- Resistance chart [Chapter 5](#)
- Installation examples [Chapter 5](#)

Technical Data

Type	Power 50/60 Hz gramm/hour	Chemical consumption litre/hour		Power consumption approx. kW	Weight (empty) approx. kg
		HCl	NaClO ₂		
CDG - 125.1	125	3,2	3,2	0,2	64
CDG - 220.1	220	5,5	5,5	0,2	64
CDG - 500.1	500	12,6	12,6	1,5	70
CDG - 1000.1	1000	25,2	25,2	1,5	75

Dimensional drawing

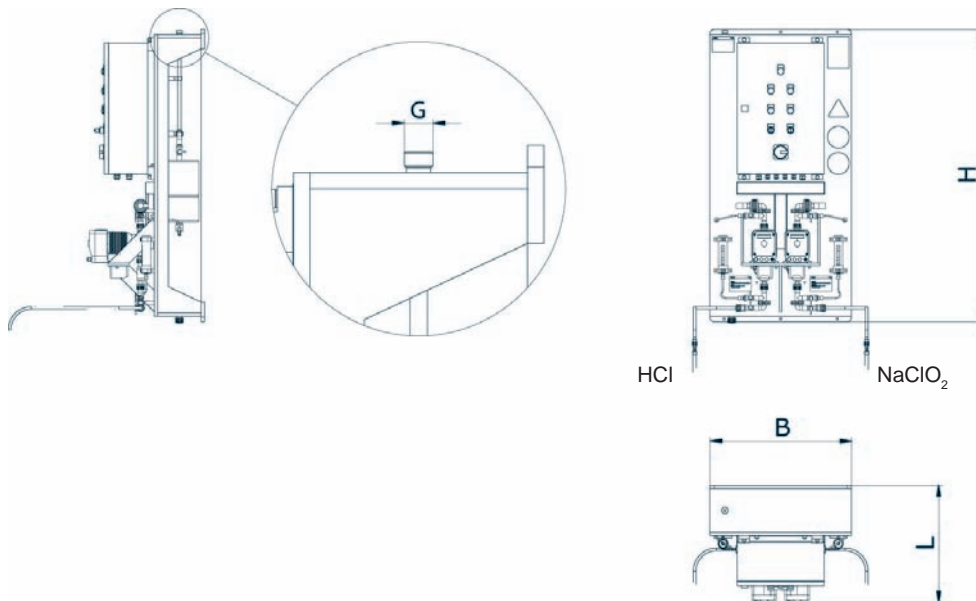

Dimensional chart
All indications in mm

Typ	Process connection G	L	B	H
CDG - 125.1	G 3/4	530*	650	1350
CDG - 220.1	G 3/4	530*	650	1350
CDG - 500.1	G 3/4	590*	650	1350
CDG - 1000.1	G 3/4	590*	650	1350

Electrical data / Control technology

Input	3 digital inputs 1 analogue input (adjustable)	Fault external controller, external ON, external stream bypass (4...20mA) controller or water meter
Output	3 potential free outputs 1 output 230 V	Pre-alarm tank, release controller, collective fault Voltage supply (e.g. for ClO ₂ -measuring)
Enclosure	Control cabinet Solenoid-diaphragm pump (CDG - 125.1 u. - 220.1) Diaphragm pump (CDG - 500.1 u. - 1000.1)	IP 65 IP 65 IP 55
Supply voltage	230 V / N / PE, 50 Hz	

Order information

Basic design

Chlorine dioxide-production unit

- 2 Dosing pumps of C-series
- 2 Flow meter
- 2 Calibration pot
- 2 Pressure switch
- 1 Reactor
- Fittings, hoses, brackets
- 2 suction lance with pre-alarm + run dry protection
- 2 Adapter for suction lance for drum
- Control device (impulse/analog input)
- Wall mounting frame (PP)

Type	Basic design	x
CDG - 125.1	25000849	
CDG - 220.1	25000777	
CDG - 500.1	25000850	
CDG - 1000.1	25000778	

Options/Accessories		x
Thinning water unit		▲
Chemical gas absorber	for HCl	▲
	for NaClO ₂	▲
Contact water meter (main current)		▲
ClO₂ - Measuring and control unit		▲
ClO₂ - photometer (for fast determination of ClO ₂ - concentration)		▲
Drum for HCl (without filling)	30 Litre	▲
	60 Litre	▲
Drum for HCl (incl. filling, 9-percent solution)	30 Litre	▲
	60 Litre	▲
Drum for NaClO₂ (without filling)	30 Litre	▲
	60 Litre	▲
Drum for NaClO₂ (incl. filling, 7,5-percent solution)	30 Litre	▲
	60 Litre	▲
Collecting basin for drum	Content appr. 30 Litre	▲
	Content appr. 60 Litre	▲
BUS-connection	Profibus DP / Slave	▲
	Ind. Ethernet	▲
further accessories on request		
<p>● = Basic design – = not available ▲ = with add. price ⊗ = on request ○ = without add. price Art.-No. = available as basic design/ accessories</p>		

PDS -...

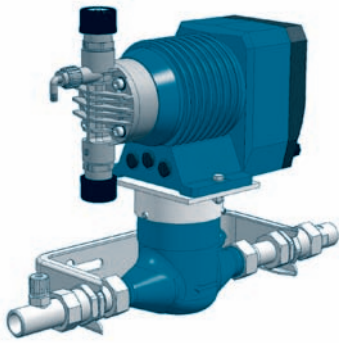

Proportional dosing system in survey

- Dosing system ready to operate
- The most modern pump technology
- Space-saving compact design
- Infinitely variable capacity
- Quantity based dosing
- Highest accuracy
- Easy to operate
- Low maintenance
- Complete accessories program

Infobox

Order information [Page 1.19](#)
Options/Accessories [Page 1.19](#)

Resistance chart [Chapter 5](#)
Installation examples [Chapter 5](#)

Technical data

Type	Nominal capacity		Permissible counter-pressure bar	Permissible suction height mWC	Power consumption approx. kW	Input supply voltage 1~, 50/60 Hz V	Weight approx. kg
	litre/minute	ml/stroke					
PDS - 1,2	0 - 1,2	0 - 0,13	10	3	0,05	230	6,0
PDS - 2,4	0 - 2,4	0 - 0,27	10	3	0,05	230	7,0
PDS - 6,0	0 - 6,0	0 - 0,67	6	3	0,05	230	7,0
PDS - 7,0	0 - 7,0	0 - 0,78	10	3	0,05	230	7,5
PDS - 10	0 - 10	0 - 1,11	6	3	0,05	230	8,0

Pulse sequence 0,5 Litre/pulse (more pulse sequences on request)

Dimensional drawing

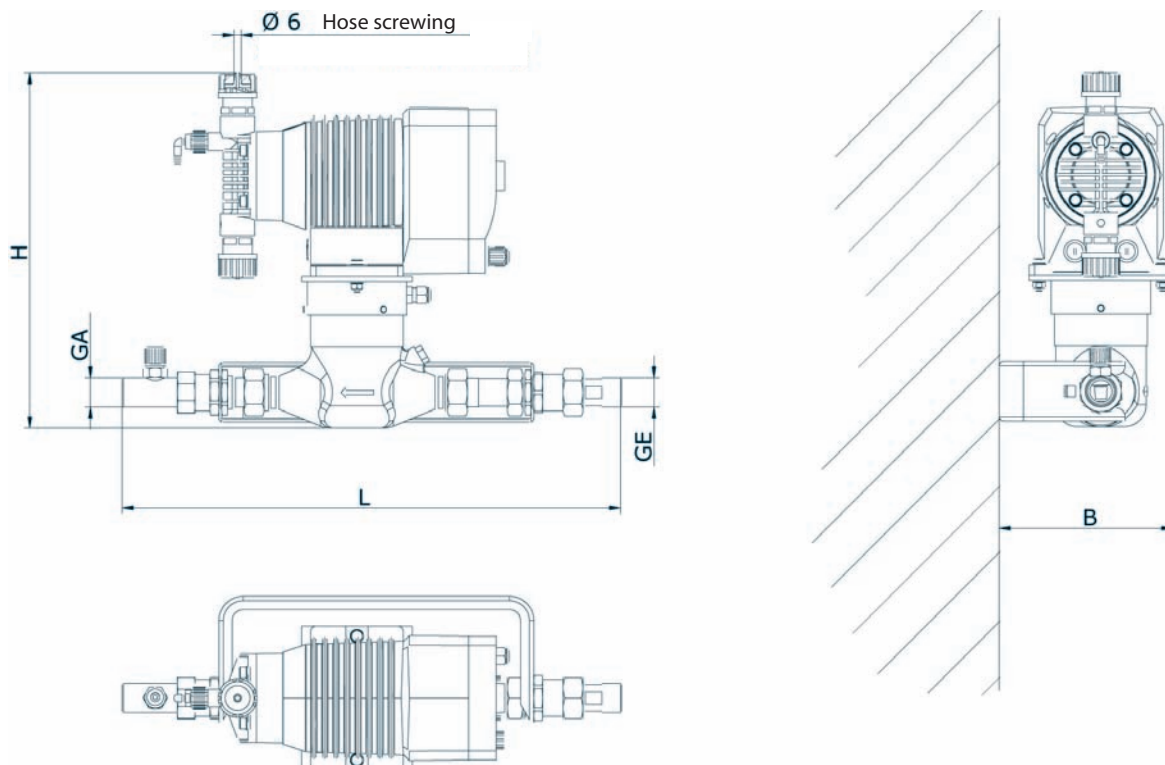

Dimensional chart
All indications in mm

Type	L	B	H	Process connection	
				GE (Inlet)	GA (Outlet)
PDS - 1,2	450	157	320	R1	R1
PDS - 2,4	450	157	320	R1	R1
PDS - 6,0	450	157	320	R1	R1
PDS - 7,0	450	157	320	R1	R1
PDS - 10	450	157	320	R1	R1

Order information

Basic design

Proportional dosing system PDS

- Solenoid diaphragm pump
- Contact water meter DA 20
- Dosing valve
- Calibration pot
- Suction lance
- Wall fixing device
- 2m dosing hose, PE, 4/6

Type	x
PDS - 1,2	
PDS - 2,4	
PDS - 6,0	
PDS - 7,0	
PDS - 10	

Options/Accessories		x
Contact water meter	DA 25	▲
	DA 40	▲
Dosing hose, PE, 4/6	5m	▲
	10m	▲
further accessories on request		
<p>● = Basic design – = not available ▲ = with add. price Ⓒ = on request ○ = without add. price Art.-No. = available as basic design/ accessories</p>		

KKV...

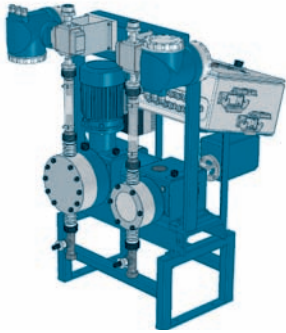

KKV-Dosing system in survey

- Fully automatic operation
- Highest accuracy
- The most modern control- and pump technology
- High operational safety
- Easy to operate
- High lifetime
- Low maintenance
- Complete accessory programme

Infobox

Order information [Page 1.21](#)
Options/Accessories [Page 1.21](#)

Resistance chart [Chapter 5](#)
Installation examples [Chapter 5](#)

Technical data

Type	total capacity 50/60 Hz litre/minute	Chemical consumption litre/hour		Power consumption kW	Weight kg
		Color	Lye		
KKV-20,8.1	20,8	1000	250	approx. 1,0	approx. 170

Dimensional drawing

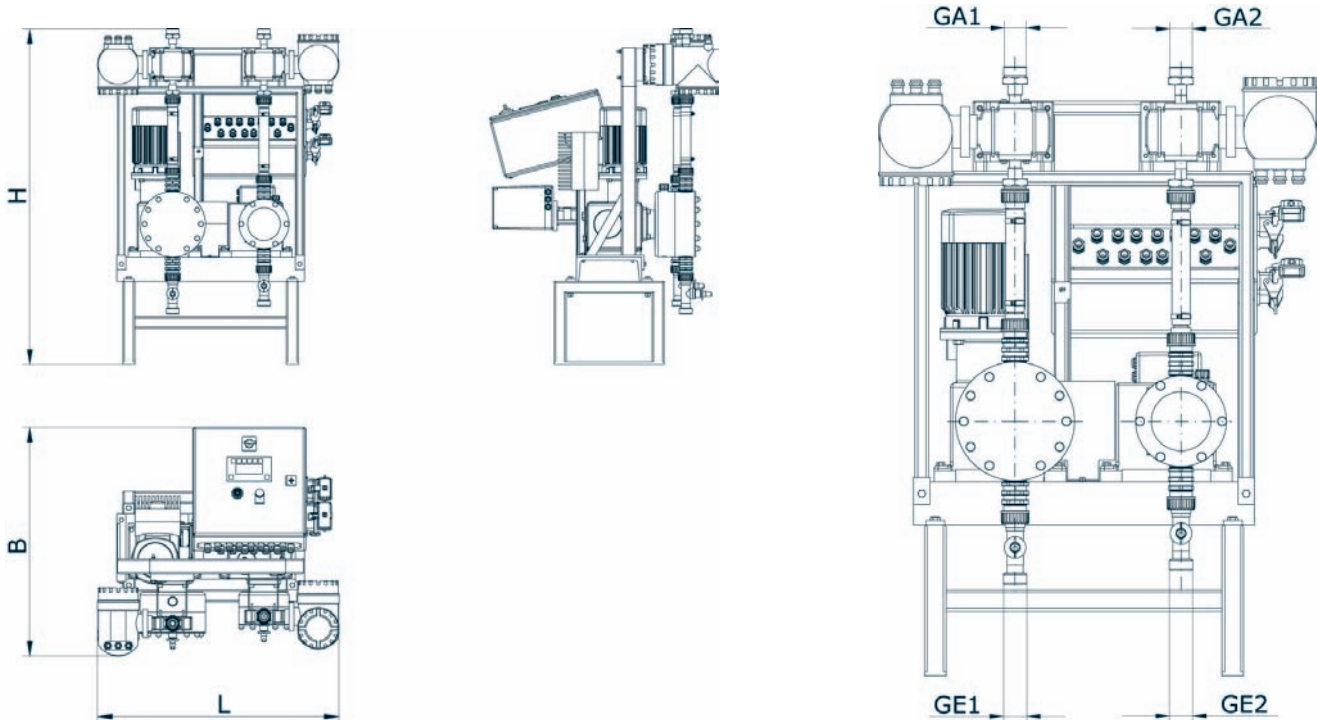

Dimensional chart
All dimension in mm

Type	L	B	H	Dosage color		Dosage lye	
				GE1	GA1	GE2	GA2
KKV - 20,8.1	815	770	1130	G1 1/4	G1 1/4	G1 1/4	G1 1/4

Electrical data / control technology

Input	4 digital inputs (potential bonded): 1 analogue input	release pump, release control, fast stop, pump flushing 0/4-20 mA from external fill level controller or external fill level measurement (analog signal must be potential-free)
Output	4 potential free outputs	flush valve, drain valve, color ready, collective fault
Supply voltage	3 x 400 V / 50 Hz / N / PE	
Enclosure	IP54	
Control voltage 1	230 V / 50 Hz	
Control voltage 2	24 V DC	

Order information

Basic design

KKV-Dosing system

- Dosing pump
Type RF 411.1-1100e/RK 411.1-550e
- Driving motor with integrated frequency converter
- Mounted actuator (lye-dosage)
- Stroke frequency transmitter
- 2 magneto-inductive flow controllers
- 2 capacitive sensors for fluid monitoring
- Mounted control (PLC-technology) with operator panel
- System-wiring and -piping incl. mounting-frame

Type	x
KKV - 20,8 . 1	

1

Options/Accessories		x
Diaphragm pressure-keeping valve	Type 624.D	▲
Connection parts for diaphragm pressure-keeping valve		▲
Suction basket	Type 722	▲
Suction basket	Type 724	▲
T-piece made of PVC, DN25		▲
PVC-hose with cross-textile ply	16/24	▲
	32/42	▲
Hose clamp	16/27	▲
	32/50	▲
further accessories on request		
<p>● = Basic design – = not available ▲ = with add. price ⊗ = on request ○ = without add. price Art.-No. = available in basic design/ accessories</p>		

DG - ...

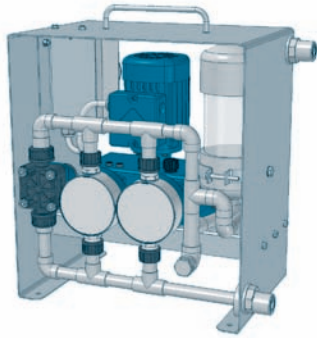

Dosing device in survey

- Mobile, ready-to-use dosing system
- Rack made of stainless steel
- Integrated overpressure protection
- Electrical protection over motor protection switch
- Pulsation poor
- Infinitely adjustable delivery rate
- Highest accuracy
- Nearly pressure independent performance curves
- Easy to operate
- Low maintenance
- Complete accessories program

Infobox

Order information [Page 1.23](#)
Options/Accessories [Page 1.23](#)

Resistance chart [Chapter 5](#)
Installation examples [Chapter 5](#)

Technical data

Type	Nominal capacity	Permissible counterpressure	Permissible suction height	Power consumption (approx.) kW	Weight
	litre/hour				
DG - 200	0 - 200	4	3	0,18	23
DG - 400	0 - 400	4	3	0,18	29
DG - 600	0 - 600	4	3	0,18	35

Dimensional drawing

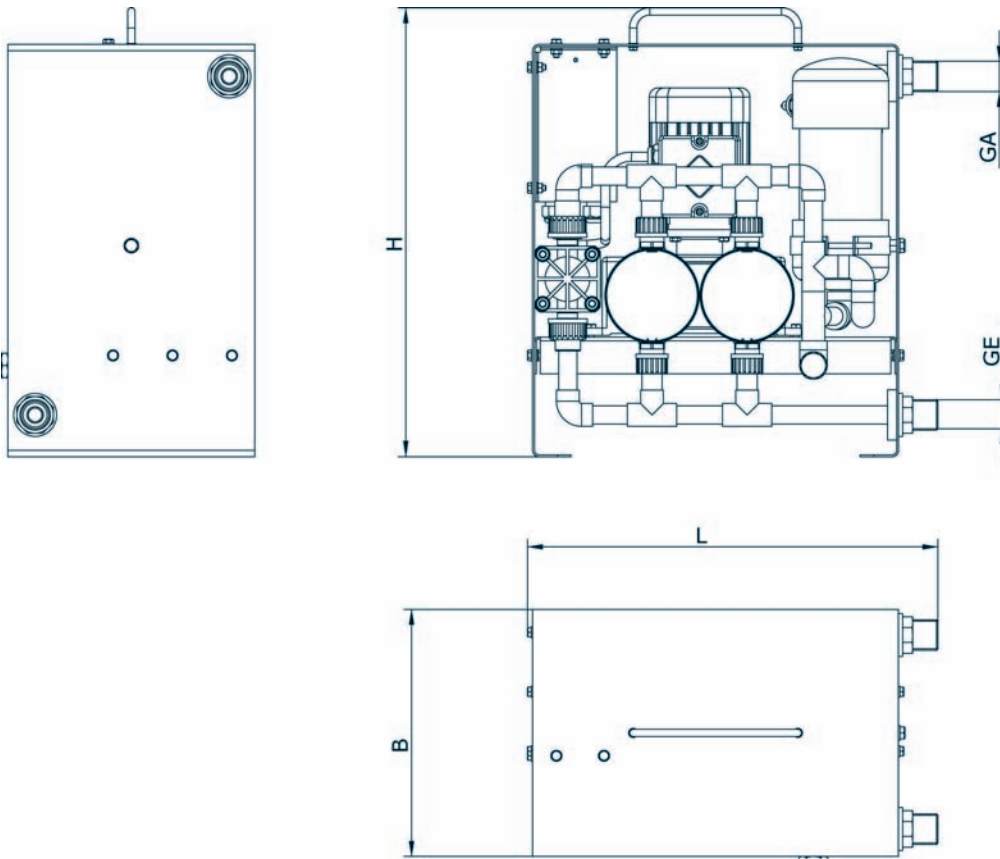

Dimensional chart

All dimenisons in mm

Type	L	B	H	Process connection	
				GE (Inlet)	GA (Outlet)
DG - 200	450	450	490	G1	G1
DG - 400	450	450	490	G1	G1
DG - 600	450	450	490	G1	G1

Order information

Basic design

Dosing device DG

- Dosing pump with three-phase motor
DG - 200 : R 409.1-190e
DG - 400 : ZR 409.1-190e
DG - 600 : DR 409.1-190e
- Flow display
- Motor protection switch
- Diaphragm-type relief valve
- Pulsation damper
- Bracket
- Rack made of stainless steel
- Connection pipe (delivered loose)
- Spray nozzle
- 5m dosing hose (EPDM)

Type	Basic design	x
DG - 200	25000038	
DG - 400	25000039	
DG - 600	25000040	

Options/Accessories

			x
AC motor		▲	
Dosing hose	EPDM, 13/20	▲	
	EPDM, 19/27	▲	
Check valve		▲	
Automatic switch-off in case of bulk shortage		▲	
Alarm-automatic switch-off in case of fluid shortage		▲	

further accessories on request

● = Basic design -- = not available ▲ = with add. price © = on request ○ = without add. price Art.-No. = available as basic design/ accessories

MDG -...

1

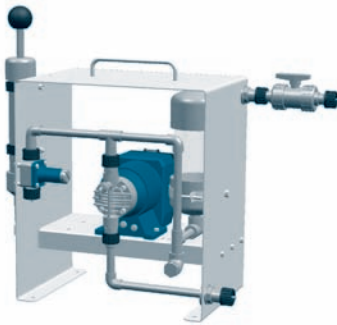

Mobile dosing devices in survey

- Mobile, ready to use dosing systems
- Modern pump technology
- Rack made of stainless steel
- Flow display
- Integrated overpressure protection
- Pulsation poor
- Infinitely adjustable delivery rate
- Highest accuracy
- Easy to operate
- Low-maintenance
- Complete accessory programme

Infobox

Order information [Page 1.25](#)
Options/Accessories [Page 1.25](#)

Resistance chart [Chapter 5](#)
Installation examples [Chapter 5](#)

Technical data

Type	Nom. capacity	Permiss. counterpressure	Permiss. suction height	Power consumption (approx.) kW	Input suply voltage	Weight
	litre/hour				bar	
MDG - 1,2	0 - 1,2	4	3	0,05	230	15
MDG - 2,4	0 - 2,4	4	3	0,05	230	15
MDG - 6,0	0 - 6,0	4	3	0,05	230	15
MDG - 14	0 - 14	3	3	0,05	230	15
MDG - 30	0 - 30	2,5	3	0,05	230	15

Dimensional drawing

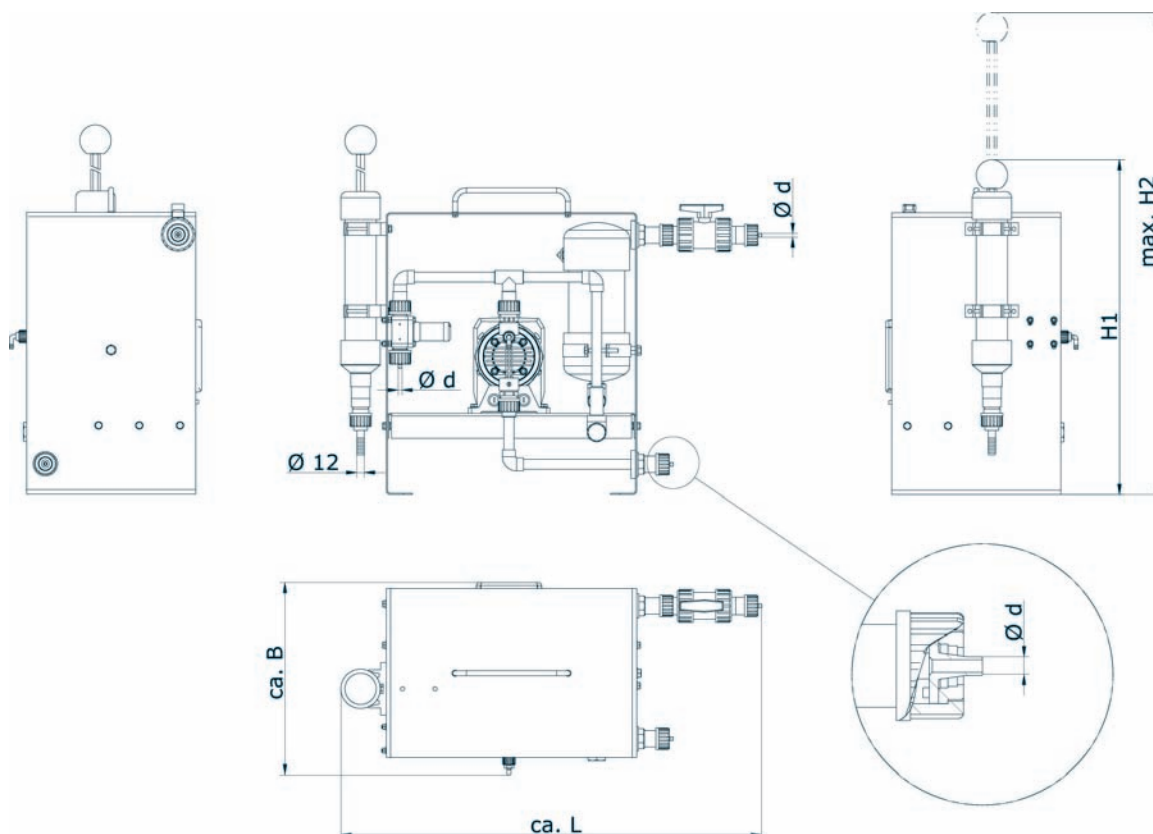

Dimensional chart
All indications in mm

Type	L	B	H1	H2	Hose screwing (6/12) Ø d
MDG - 1,2	675	310	535	770	6
MDG - 2,4	675	310	535	770	6
MDG - 6,0	675	310	535	770	6
MDG - 14	675	310	535	770	6
MDG - 30	675	310	535	770	6

Order information

Basic design

Dosing device

- Solenoid diaphragm pump
- Flow display
- Diaphragm-type relief valve
- Pulsation damper
- Bracket
- Rack made of stainless steel
- Hand vacuum pump

Type	x
MDG - 1,2	☐
MDG - 2,4	☐
MDG - 6,0	☐
MDG - 14	☐
MDG - 30	☐

Options/Accessories		x
Hose made of PVC-U	▲	☐
Hose screwing for PVC-U-hose	▲	☐
Suction lance Type SL-11.1	▲	☐
Dosing valve Type 691.1	▲	☐
further accessories on request		
<p>● = Basic design – = not available ▲ = with add. price ☉ = on request ○ = without add. price Art.-Nr. = available as basic design/ accessories</p>		

KDO - ...



KDO in survey

- The most modern pump technology
- Standardized dosing tanks
- Space-saving design
- Wide application range
- High safety standard
- High-quality materials
- Easy to operate
- Low maintenance
- Complete accessory programme

Infobox

- Order information [Page 1.27](#)
- Options/Accessories [Page 1.27](#)
- Resistance chart [Chapter 5](#)
- Installation examples [Chapter 5](#)

Technical data

Type	Tank volume litre	conveying capacity litres/hour	max. permissible counterpressure bar	Quantity pumps	Diaphragm pump series
KDO - 75.1	75	0,6 ... 350	up to 10	1	R/C 204.1, R/C 409.2, R 302
KDO - 100.1	100	0,6 ... 350	up to 10	1	R/C 204.1, R/C 409.2, R 302
KDO - 200.1	200	0,6 ... 350	up to 10	1	R/C 204.1, R/C 409.2, R 302
KDO - 300.1	300	0,6 ... 350	up to 10	1	R/C 204.1, R/C 409.2, R 302
KDO - 500.1	400	0,6 ... 1450	up to 10	1	R/C 204.1, R/C 409.2, R 302, R 410.2
KDO - 1000.1	500	0,6 ... 1450	up to 10	1	R/C 204.1, R/C 409.2, R 302, R 410.2

Dimensional drawing

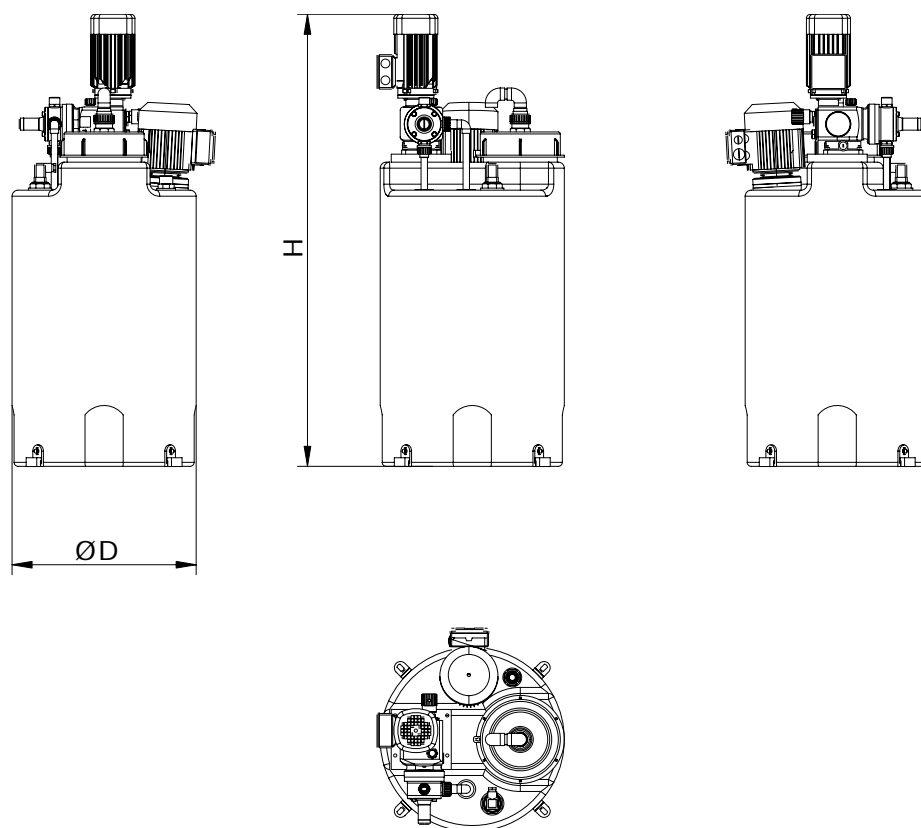

Dimensional chart

All indications in mm

Type	D	max. H*
KDO - 75.1	460	840
KDO - 100.1	460	840
KDO - 200.1	600	980
KDO - 300.1	670	1050
KDO - 500.1	790	1280
KDO - 1000.1	1080	1570

* The measure H varies dependent on the use of the respective pump series . Please see the product pages of diaphragm pumps.

Order information

Basic design

Packaged units KDO

- Dosing tank
(PE-transparent) with litre scale
- Diaphragm pump
- Suction lance

Type	x
KDO - 75.1	
KDO - 100.1	
KDO - 200.1	
KDO - 300.1	
KDO - 500.1	
KDO - 1000.1	

Options/Accessories			x
Solenoid float switch (level switch)	single-stage (e.g. Min.-contact)	▲	
	double-stage (e.g. Min./Max.-contact)	▲	
Manual agitator	Manual stamping mixer	▲	
	Manual stamping mixer, gas tight	▲	
	Manual agitator	▲	
	Manual agitator, gas tight	▲	
Electric agitator	different performances and mixing organs possible	▲	
Level indicator for dosing tank	made of PVC-transparent for tank level monitoring	▲	
Filling joint		▲	
Breather joint		▲	
Ventilation joint	tank ventilation mounted in screw top	▲	
Drain joint		▲	
Shut-off cock (for drain joint)		▲	
further accessories on request			
● = Basic design – = not available ▲ = with add. price Ⓞ = on request ○ = without add. price Art.-No. = available in basic design/ accessories			

Industrial solutions

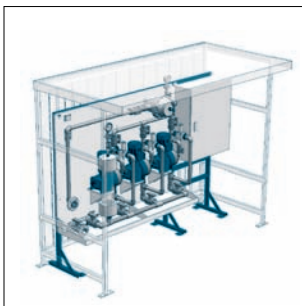
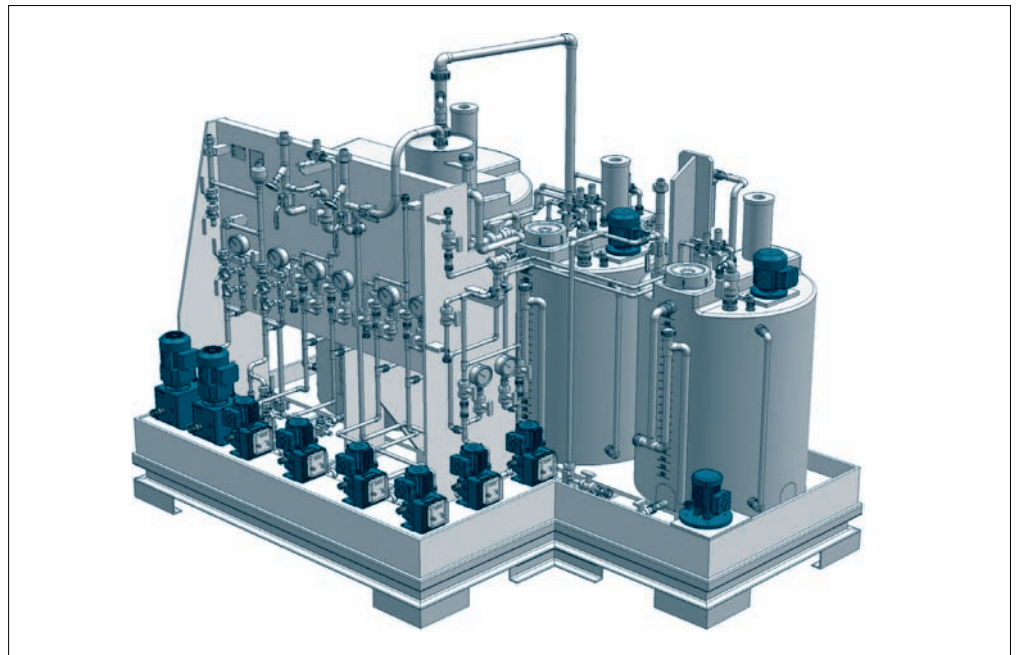
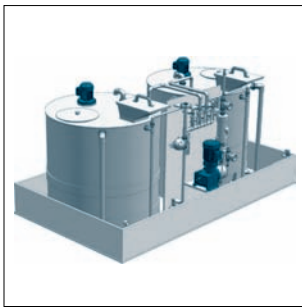
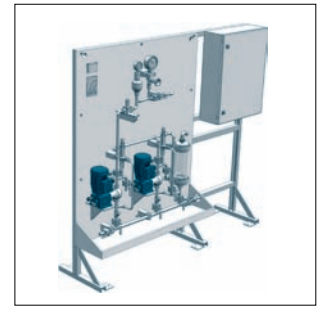
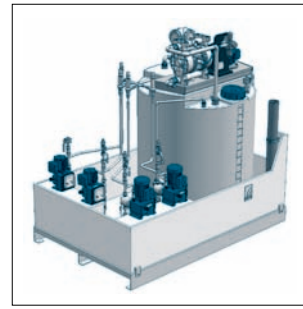
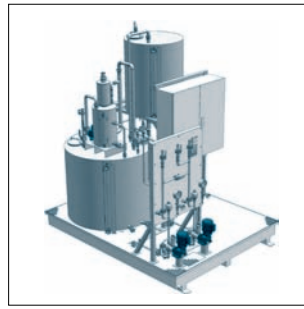

SERA - Dosing units and -systems are used in following industry sectors:

- Sewerage Technology
- Brewery- / Beverage Industry
- Chemical Industry
- Printing Industry
- Iron- and Steel Industry
- Electrical- and Semiconductor Industry
- Energy Technology
- Domestic Technology
- Power plants
- Agriculture
- Food Industry
- Mechanical Engineering
- Dairies
- Surface Technology
- Paper Industry
- Petrochemistry
- Pharmaceutical Industry
- Swimming baths
- Textile Industry
- Environmental Technology
- Water conditioning

If you do not find your industry sector in this list, do not hesitate to contact us. We can also offer you an optimal solution for your application from our wide product range.

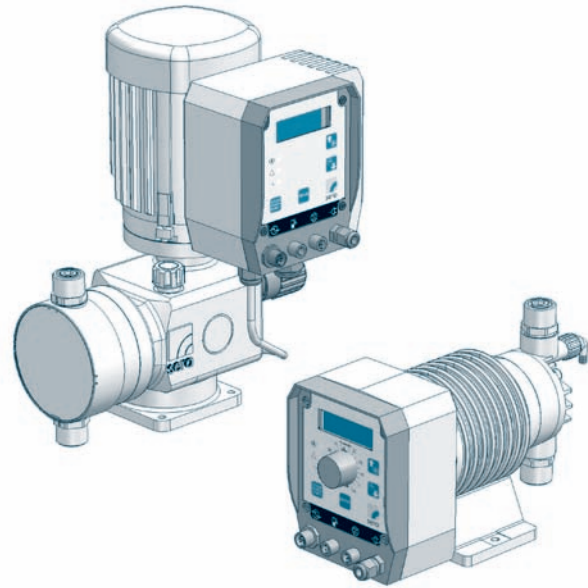

The following products are usually used in SERA - dosing units and dosing systems:

- Storage- and dosing tanks
- Collecting basins
- Dosing pumps
- Feeding pumps
- Dry feeder
- Agitators
- Fittings
- Complete controls incl. measuring technics

Only high-quality, media-resistant materials are used:

- PVC-U
- PTFE
- PP
- Stainless steel (e.g. 1.4571)
- PE
- Hastelloy
- PVDF
- Rubber-lined C-steel

Advantages of SERA - dosing units and dosing systems:

- High reliability and availability
- Low operating and maintenance costs
- Easy to operate
- Complete systems all from SERA
- Full after-sales-service
- Custom-designed solutions
- Chemical-resistant material designs

Preparation units (e.g. for boiler feed water - chemicals)

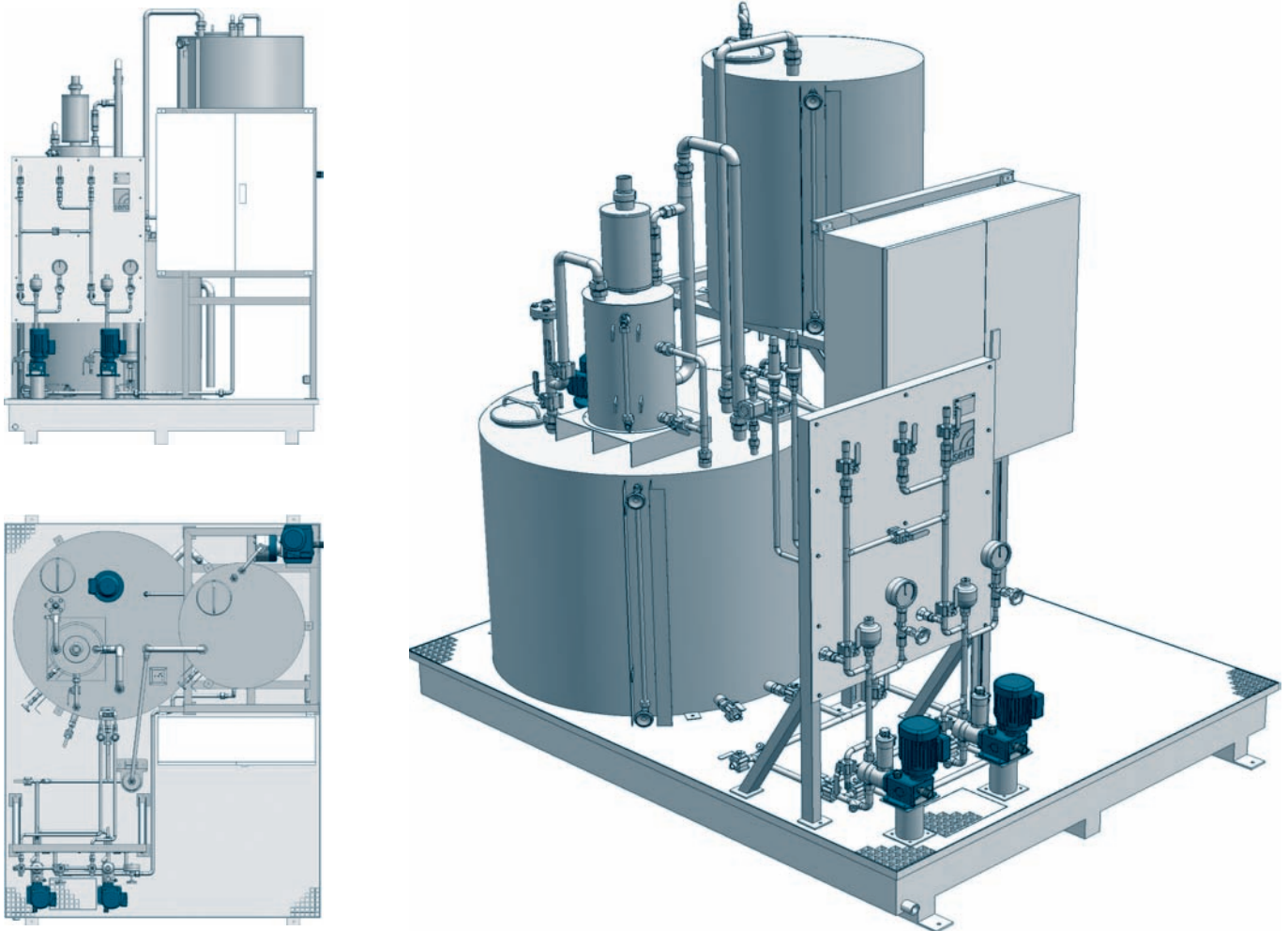

Technical key features*

Tank volumes	Preparation tank:	up to 500 Litres
	Dosing tank:	up to 5.000 Litres
Quantity of dosing pumps	any	
Operating pressure	up to 200 bar	
Operating mode	continuous or charge wise	
Preparation	manual or automatic	
Controlling	for fully automatic dosage	

* further designs on request

Preparation units (e.g. for boiler feed water - chemicals)

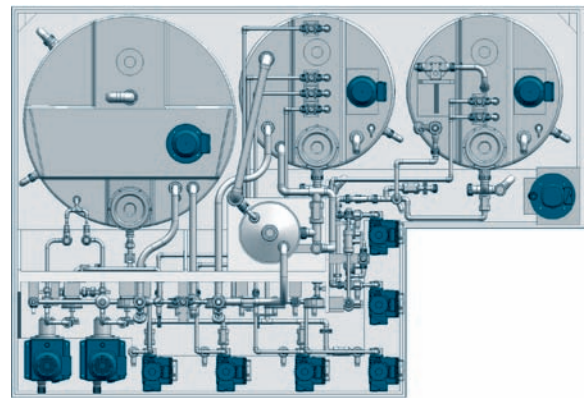
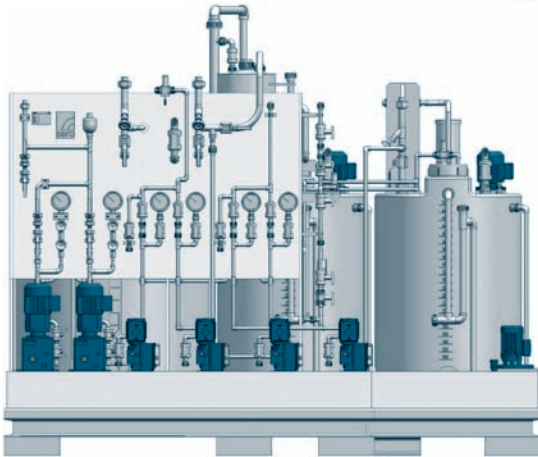
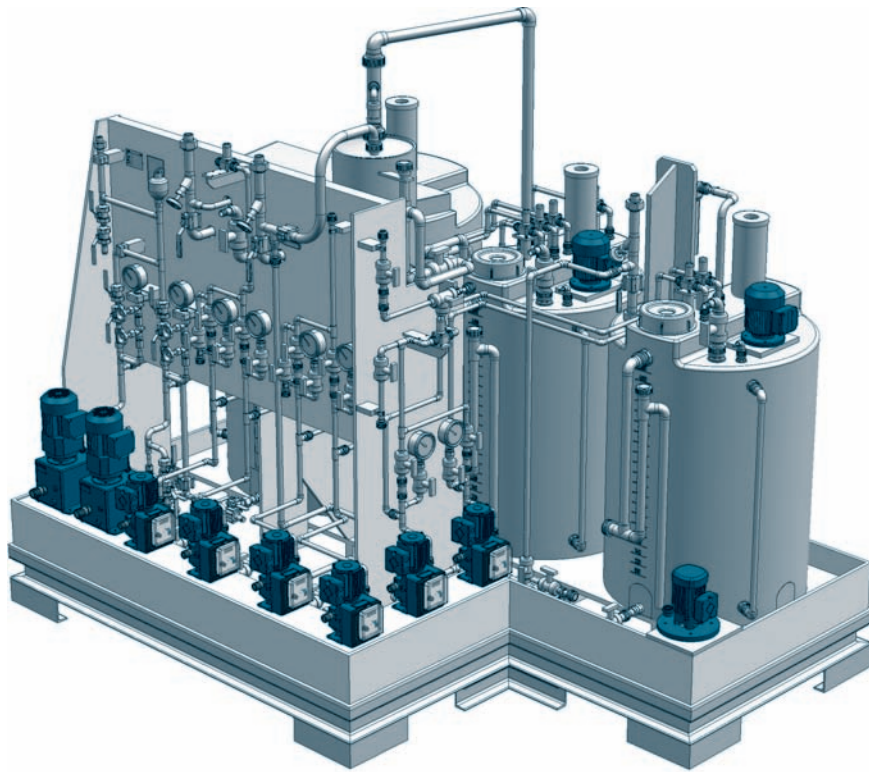

Technical key features*

Tank volumes	up to 2.000 litres
Quantity of tanks	up to 3
Operating pressure	up to 200 bar
Operation mode	continuous or charge wise
Preparation	manual or automatic
Control	for fully automatic dosage

* further designs on request

Preparation- and dosing units (e.g. for suspensions, lime milk or calcium sulphate)

1

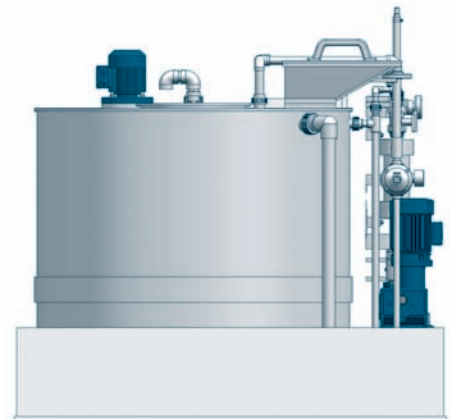
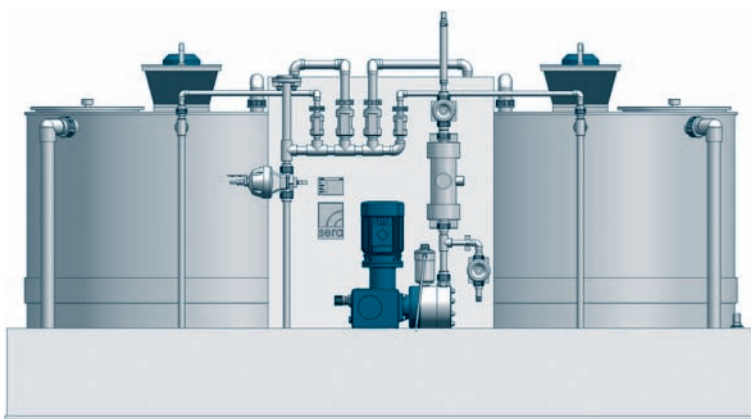
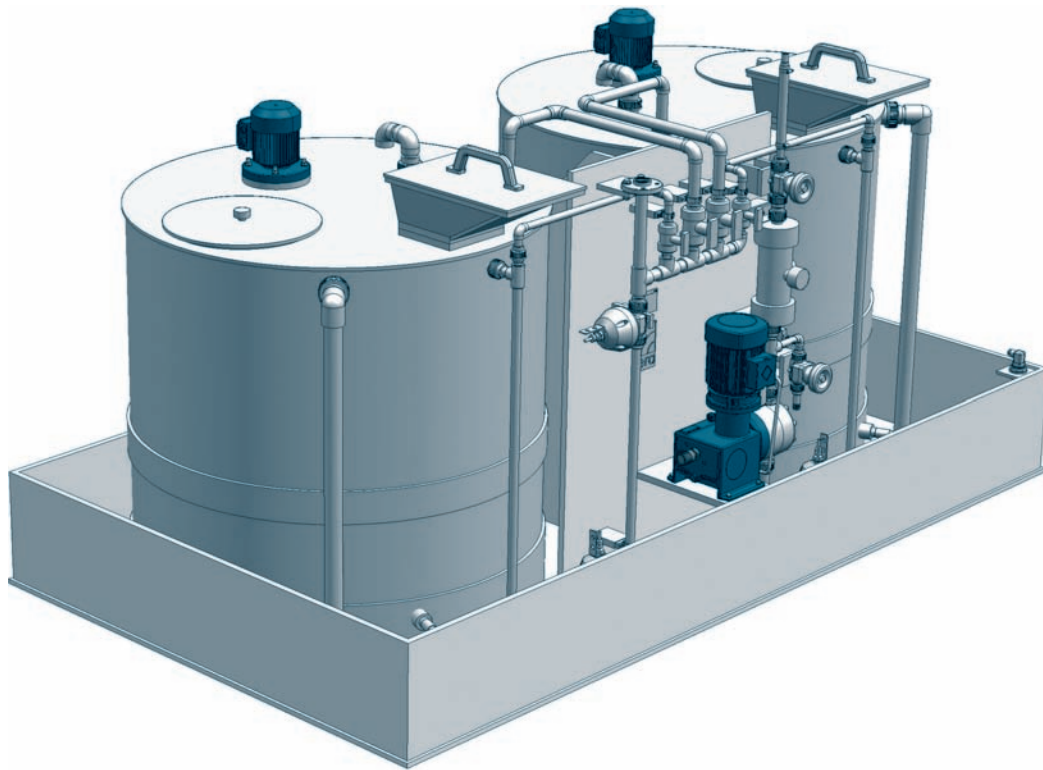

Technical key features*

Tank volumes	up to 3.000 litres
Quantity of dosing pumps	any
Operation pressure	up to 10 bar
Operation mode	continuous or charge wise
Preparation	manual or automatic
Control	for fully automatic dosage

* further designs on request

Preparation units (e.g. for suspensions, lime milk or calcium sulphate)

1

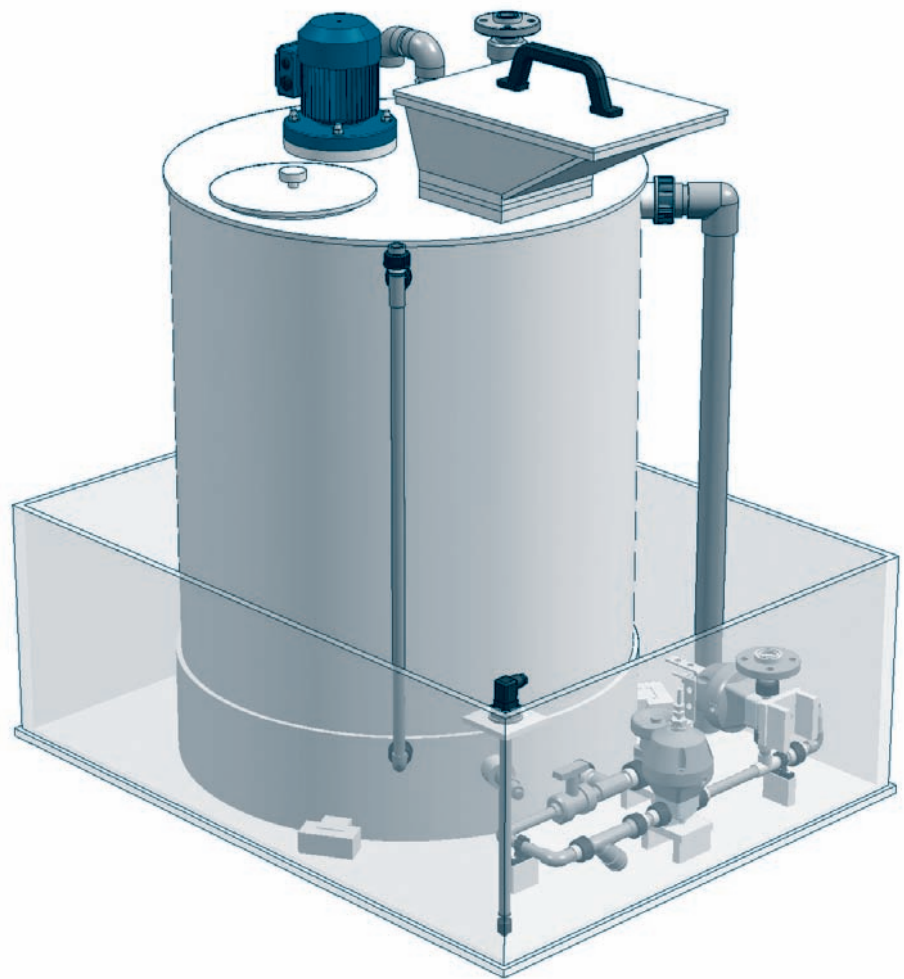
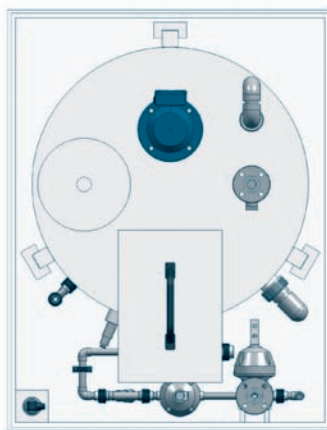

Technical key features*

Tank volumes	up to 5.000 litres
Operating mode	charge wise
Preparation	manual or automatic

* further designs on request

Storage- and dosing units (e.g. for water-endangering chemicals)

1

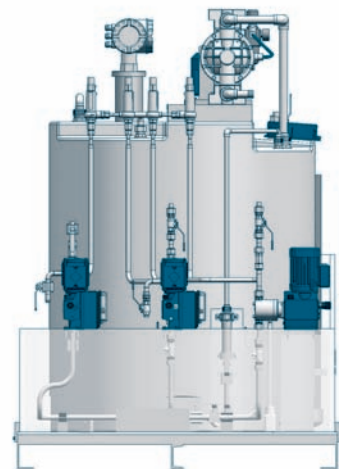
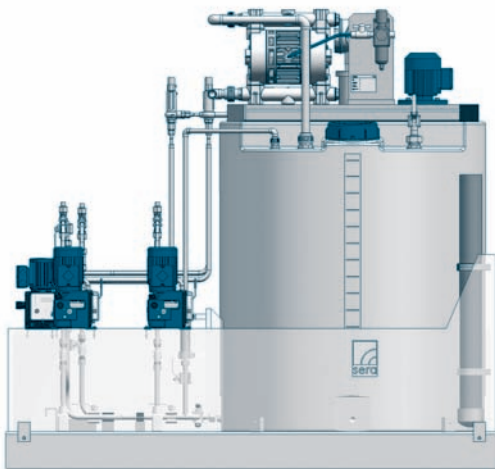
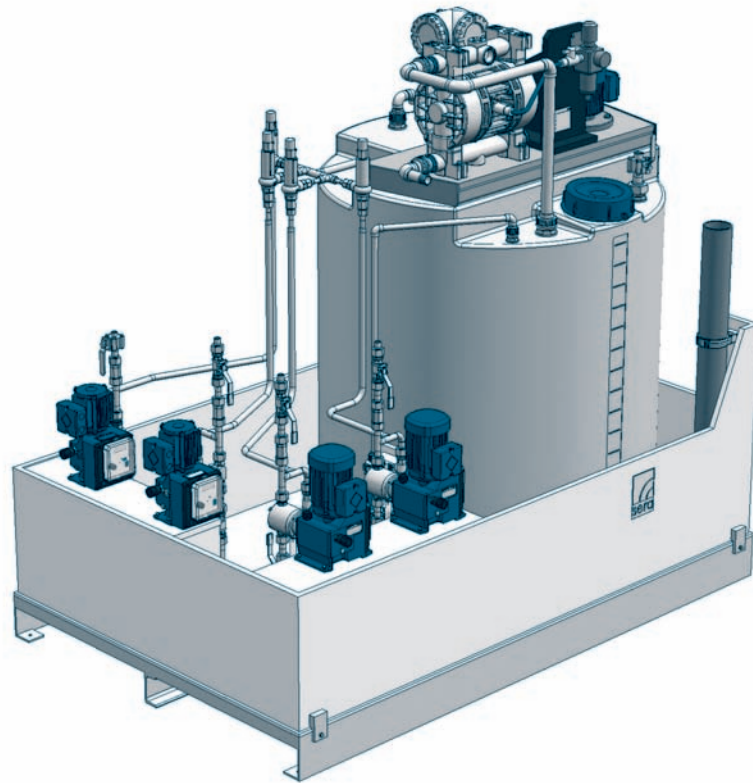

Technical key features*

Tank volumes	up to 30.000 litres
Quantity of dosing pumps	any
Operation pressure	up to 200 bar
Operation mode	continuous or charge wise
Control	for fully automatic dosage

* further designs on request

Dosing units (e.g. with protection cabinet)

1

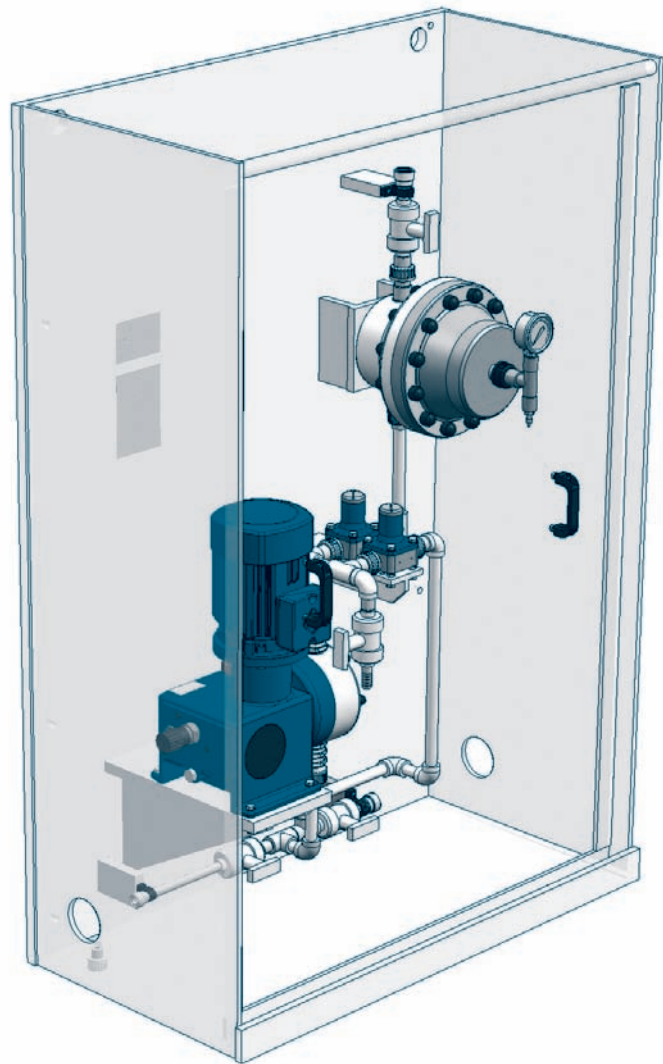
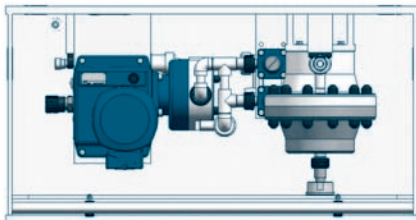
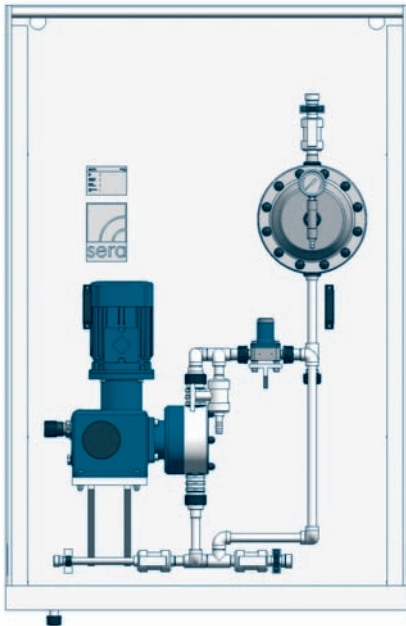

Technical key features*

Quantity of dosing pumps	up to 4
Operation pressure	up to 200 bar
Delivery rates	up to 1.500 litres/hour each pump
Operating mode	continuous or charge wise

* further designs on request

Dosing units (e.g. with protective roof for outer installation)

1

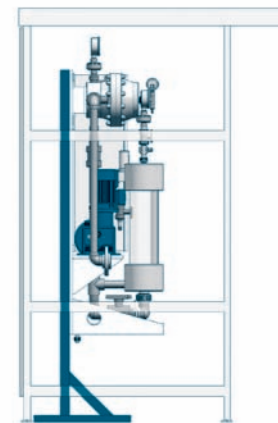
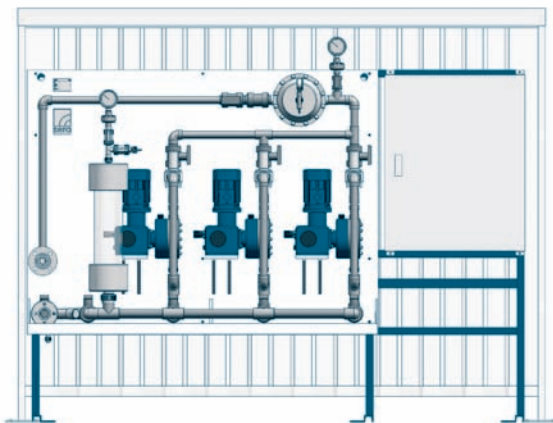
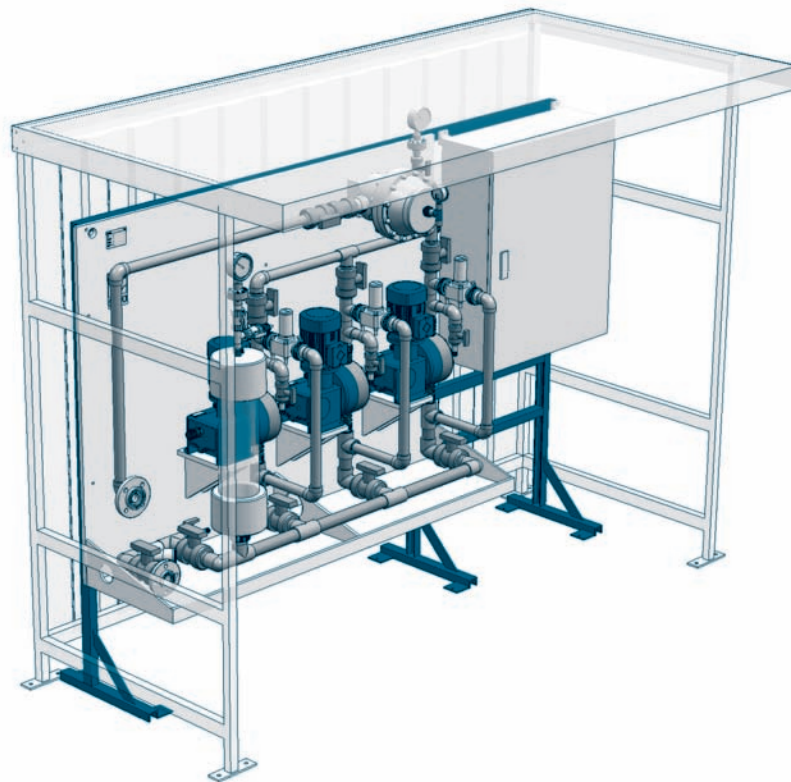

Technical key features*

Quantity of dosing pumps	up to 4
Operating pressure	up to 200 bar
Delivery rates	up to 1.500 litre/hour each pump
Operating mode	continuous or charge wise
Control	for fully automatic dosage

* further designs on request

Dosing units (e.g. for wall mounting, indoor installation)



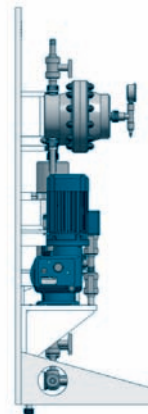
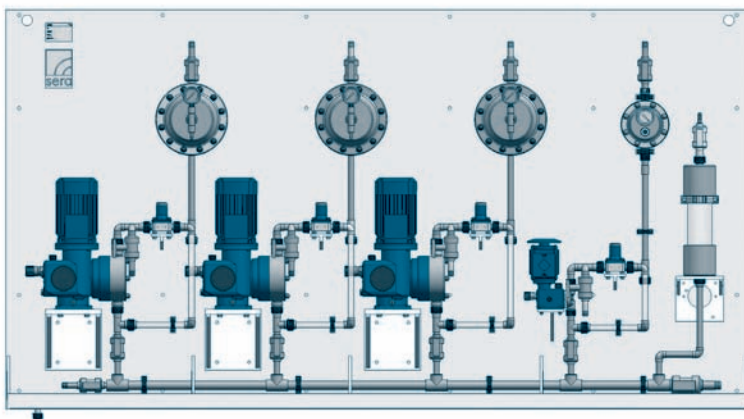
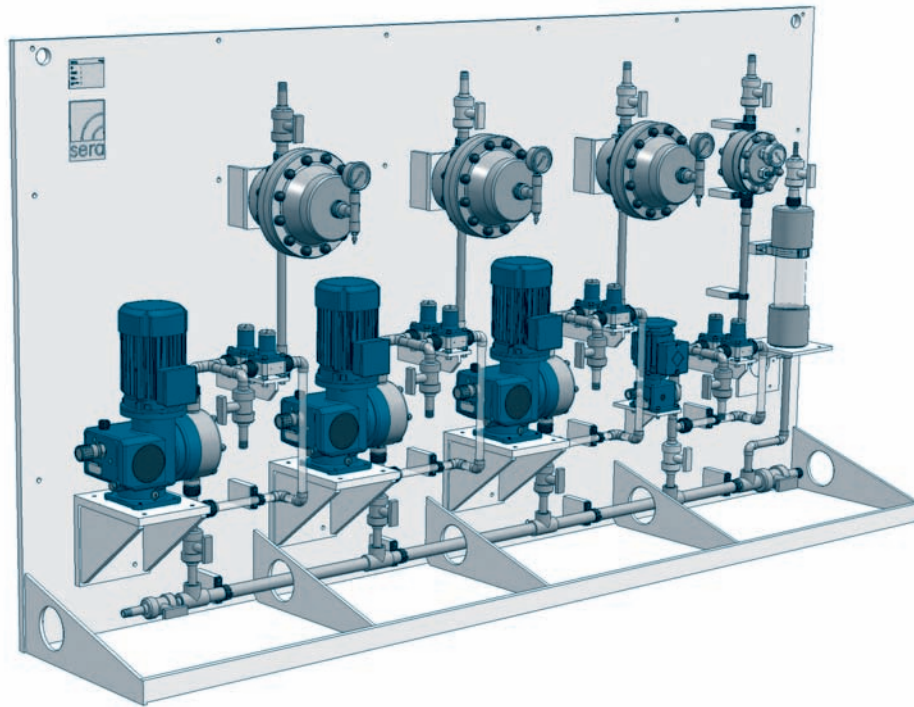





1

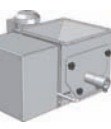

Technical key features*

Quantity of dosing pumps	up to 6
Operating pressure	up to 200 bar
Delivery rates	up to 1.500 litres/hour each pump
Operating mode	continuous or charge wise
Control	for fully automatic dosage

* further designs on request

Accessories for dosing units and -systems	Series	Page
	Dosing tanks	Round tanks made of PE 1.40
	Mixer and agitators	Manual stamping mixer Manual agitator Electric agitator 1.41
	Solenoid float switch	1-fold 2-fold 1.44
	Absorption vessel	Absorption vessel for neutralisation of outgoing air 1.46
	Dry feeder	Volumetric dosing screw (VDS) 1.47
	Flow measuring	Magneto-Inductive flow meter Mass flow meter Calorimetric flow controller 1.48
	Level measuring	Continuous level measuring Vibration limit switch Capacitive proximity switch 1.51
	Liquid analysis	pH-measuring Redox-measuring Chlorine-measuring 1.54
	Industry controller	Universal industry controller in different designs 1.57

Dosing tank



Dosing tank in survey

- UV-stabilized polyethylene, food safe
- Seamless
- Assembly bridge, centred
- Embossed litre scale
- Connection for drain
- Safe fixing
- Lockable (exempt type 35)

Infobox

- Resistance chart [Chapter 5](#)
- Installation examples [Chapter 5](#)

Technical data / Order information

Content (Litre)	Material	Weight (kg, empty)	Article-No.	x
100	PE-Transparent	5,5	90009618	
200	PE-Transparent	6,5	90009619	
300	PE-Transparent	11,0	90009620	
400	PE-Transparent	15,5	90009621	
500	PE-Transparent	23,8	90009622	
1000	PE-Transparent	42,0	30080017	

Dimensional drawing

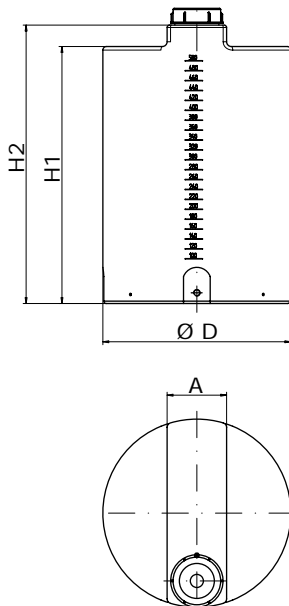

Dimensional chart
All indications in mm

Content	D	H1	H2	A
75	460	530	600	150
100	460	680	750	150
200	600	790	880	200
300	670	940	1030	300
500	790	1090	1180	250
1000 ¹⁾	1080	1260	1330	370

¹⁾ Tank incl. reinforced bridge

Options/Accessories		35	x	75	x	100	x	200	x	300	x	500	x	1000	x
Sealings EPDM		⊙		●		●		●		●		●		●	
Sealings FPM		⊙		▲		▲		▲		▲		▲		▲	
Level indicator made of PE-transparent		⊙		▲		▲		▲		▲		▲		▲	
Tank evacuation	with ball cock DN15	▲		▲		▲		▲		▲		▲		▲	
	blind closing, DN15, G1	▲		▲		▲		▲		▲		▲		▲	
Tank screwed connection incl. connection seal		▲		▲		▲		▲		▲		▲		▲	

We are ready to offer tanks with more than 1000 l contents on request. Furthermore we can supply tanks made of black PE, PP, PVC-FRP, 1.4571* as well as tanks with test mark acc. to WHG § 19 h (Water Resources Act)

● = Basic design -- = not available ▲ = with add. price ⊙ = on request ○ = without add. price Art.-Nr. = available as Basic design/ Accessories



Manual stamping mixer in survey

- For tank up to 100 litre
- Manual mixing of liquids
- Robust design
- High quality materials
- Easy to operate
- Gas-tight design (G)

Infobox

Resistance chart [Chapter 5](#)
Installation examples [Chapter 5](#)

Technical data / Order information

Type	for tank (litre / content)	Article-No. PVC-U	x	Article-No. PP	x
HM 100	35	30062001		30062005	
HM 100	75	30062001		30062005	
HM 100	100	30062002		30062006	
HM 100 G	35	30062003		30062007	
HM 100 G	75	30062003		30062007	
HM 100 G	100	30062004		30062008	

Dimensional drawing

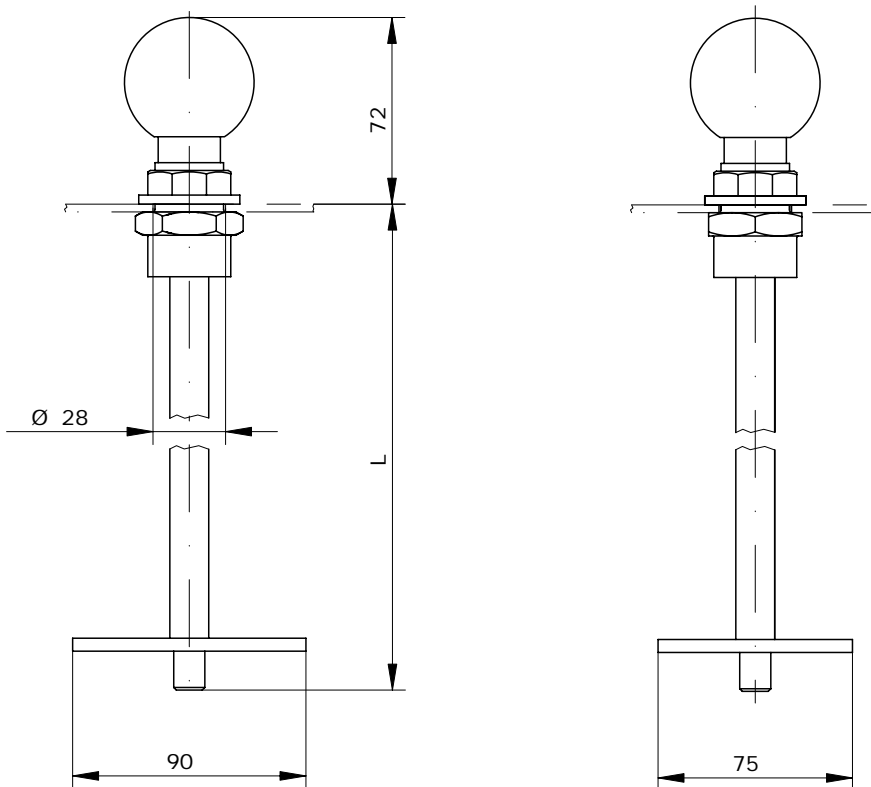

Dimensional chart

All indications in mm

Type	for tank (litre / content)	L
HM 100 / HM 100 G	35	475
HM 100 / HM 100 G	75	475
HM 100 / HM 100 G	100	625

Manual agitator



Manual agitator in survey

- For tank up to 500 litre
- Manual mixing of solutions
- Robust design
- High quality materials
- Easy to operate
- Gas-tight design (G)

Infobox

Resistance chart [Chapter 5](#)
Installation examples [Chapter 5](#)

Technical data / Order information

Type	For tank (litre content)	Article-No. PVC-U	x	Article-No. PP	x	Article-No. 1.4571	x
HM 200.1	200	30061007		30061011		⊗	
HM 200.1	300	30061008		30061012		⊗	
HM 200.1	500	30061009		30061013		⊗	
HM 200.1 G	200	30061015		30061019		⊗	
HM 200.1 G	300	30061016		30061020		⊗	
HM 200.1 G	500	30061017		30061021		⊗	

Dimensional drawing

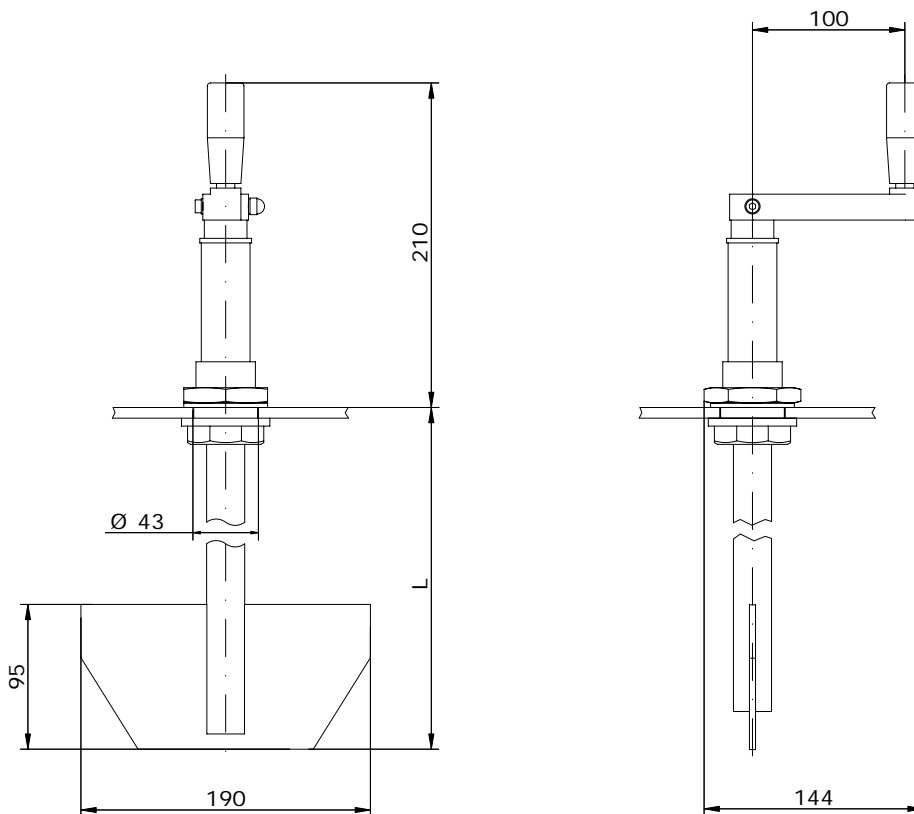

Dimensional chart

All indications in mm

Type	for tank (litre content)	L
HM 200.1 / HM 200.1 G	200	680
HM 200.1 / HM 200.1 G	300	830
HM 200.1 / HM 200.1 G	500	1020

● = Basic design -- = not available ▲ = with add. price ⊗ = on request ○ = without add. price Art.-Nr. = available as Basic design/ Accessories



Electric agitator in survey

- Balanced agitator
- Suitable for continuous operation
- No-maintenance
- Impeller can be unbolted
- High quality materials

Infobox

- Resistance chart [Chapter 5](#)
- Installation examples [Chapter 5](#)

Technical data / Order information

Type	For tank (litre content)	Shaft length (mm)	Rotation speed (min ⁻¹)	Article-No.	x
SM 1	75	450	1500	83000893	
	100	550		83000954	
SM 4	200	700	1500	90014071	
	300	800		90014835	
	500	950		83000925	
SM 8	1000	1100	1500	90014395	

Dimensional drawing

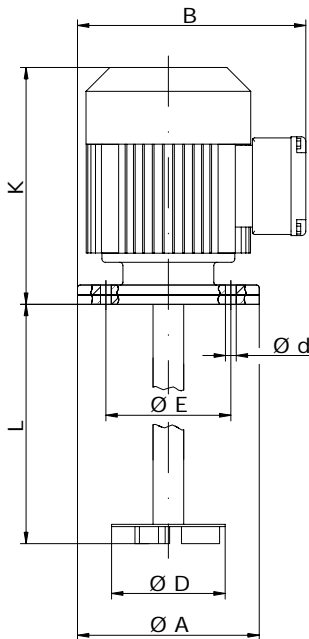

Electrical data (Drive)	SM 1	SM 4	SM 8
Drive output	0,12	0,25	0,75
Voltage	230/400 V, 50 Hz		
Protection category	IP 55		
Iso-class	F		

Dimensional chart

All indications in mm

Type	L	A	B	d	D	E	K
SM 1	450	120	appr. 280	7,0	75	100	206
	550						
SM 4	700	160	appr. 310	9,5	100	130	206
	800						
SM 8	950	200	appr. 340	11,5	150	165	240

Options/Accessories		SM 1	x	SM 4	x	SM 8	x
Materials	Shaft: 1.4571 Mixing organ: 1.4571	●		●		●	
	Shaft: 1.4571 with PVC-U-cover Mixing organ: PVDF	▲		▲		—	
	Shaft: 1.4571 with PVC-U-cover Mixing organ: PVDF	▲		▲		▲	
Protective flange	Stainless steel	▲		▲		▲	
	PVC-U	▲		▲		▲	
Seal flange	Stainless steel	▲		▲		▲	
	PVC-U	▲		▲		▲	
Special-Voltage		⊙		⊙		⊙	
Special-rotation speed	750 min ⁻¹	⊙		⊙		⊙	

● = Basic design — = not available ▲ = with add. price ⊙ = on request ○ = without add. price Art.-Nr. = available as Basic design/ Accessories

Solenoid float switch, 1-fold



**Solenoid float switch, 1-fold
in survey**

- 1 switching point, min.- or max.-message
- for thin fluid, solidsfree media
- For dosing tank 35 up to 1000 litre
- Vertical installation
- Gas-tight desing
- High quality materials
- Reliable
- Easy to mount

Infobox

Resistance chart [Chapter 5](#)
Installation examples [Chapter 5](#)

Technical data / Order information

Description	for tank (litre content)
Solenoid float switch, 1-fach	35 - 1000

Dimensional drawing

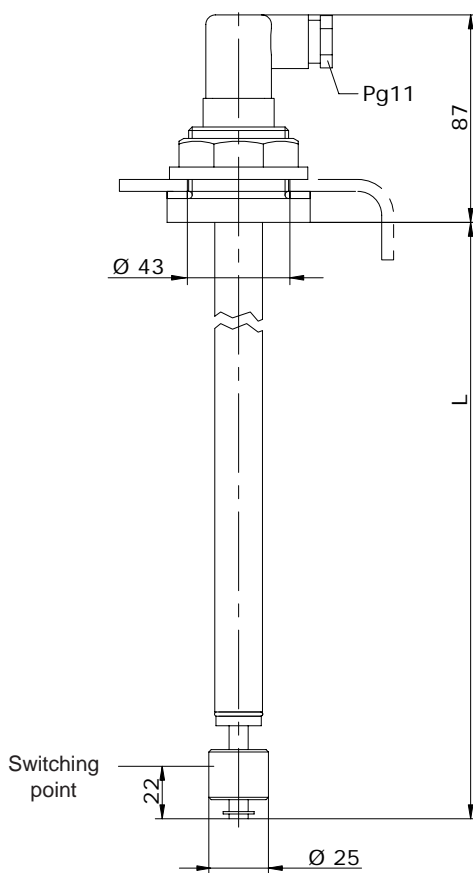

Electrical data	
Pin connections (Reed-contact)	
Turn-on voltage	Protection low voltage (<48 V AC/DC)
Switching current	max. 0,5 A
Rupturing capacity	max. 10 W / 12 VA
Float switch	
closing when floating down*	
opening when floating down**	
Attention When inductive loads are switched a protective element must be provided or a contact protective relay must be used!	

* Standard

** Function reversal by rotating the float (180°)

Dimensional chart

All indications in mm

for tank (litre content)	L (specify at order)
35	70 - 430
75	70 - 490
100	70 - 650
200	70 - 740
300	70 - 935
500	70 - 1035
1000	70 - 1150

Other length on request



Solenoid float switch, 2-fold in survey

- 2 switching points
- For thin fluid, solidsfree media
- For dosing tank form 35 up to 1000 litre
- Vertical installation
- High quality materials
- Reliable
- Easy to mount

Infobox

Resistance chart [Chapter 5](#)
Installation examples [Chapter 5](#)

Technical data / Order information

Description	for tank (litre content)
Solenoid float switch, 2-fold	35 - 1000

Note:

These solenoid float switch are not available in gas-tight design.

Dimensional drawing

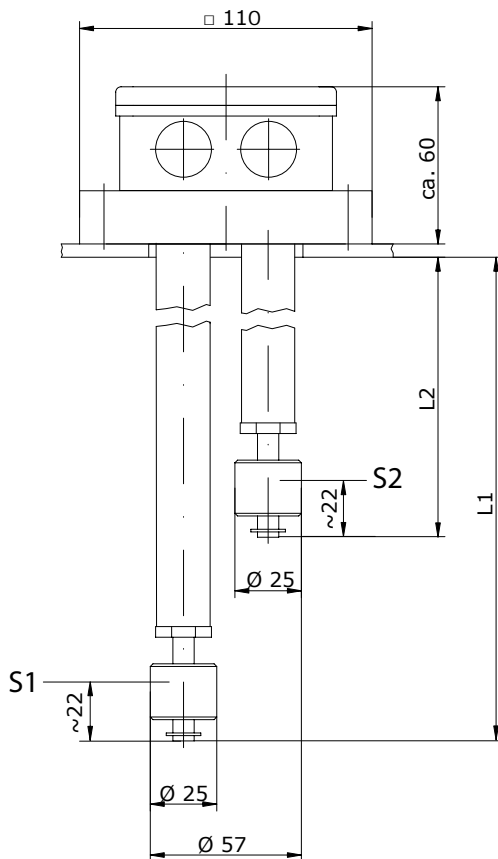

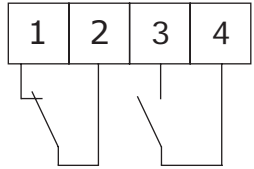
Electrical data	
Pin connections (Reed-Kontakt)	
Turn-on voltage	Protection low voltage (<48 V AC/DC)
Switching current	max. 0,5 A
Rupturing capacity	max. 10 W / 12 VA
Float switch*	
S1	Min.-contact (e.g. run-dry safety)
S2	Max.-contact (e.g. tank „full“)
<p>Attention When inductive loads are switched a protective element must be provided or a contact protective relay must be used!</p>	

* Standard: closign when floating down
Function reversal by rotating the float (180°)

Dimensional chart

All indications in mm

for tank (litre content)	L1 (specify at order)	L2 (specify at order)
35	70 - 430	70 - 430
75	70 - 490	70 - 490
100	70 - 650	70 - 650
200	70 - 740	70 - 740
300	70 - 935	70 - 935
500	70 - 1035	70 - 1035
1000	70 - 1150	70 - 1150

Other length on request

Absorption vessel



Absorption vessel in survey

- Neutralisation of outgoing air from storage tanks
- Wide application range
- Powerful
- High quality materials
- Easy to operate
- Low-maintenance

Infobox

Resistance chart [Chapter 5](#)
Installation examples [Chapter 5](#)

Technical data / Order information

Type	Materials	Article-No.	x
RKK 7 b/s	Plastics design with welded sleeve (see Dimensional drawing)	PE-HD Sealings: EPDM or FPM	Ⓞ

Dimensional drawing

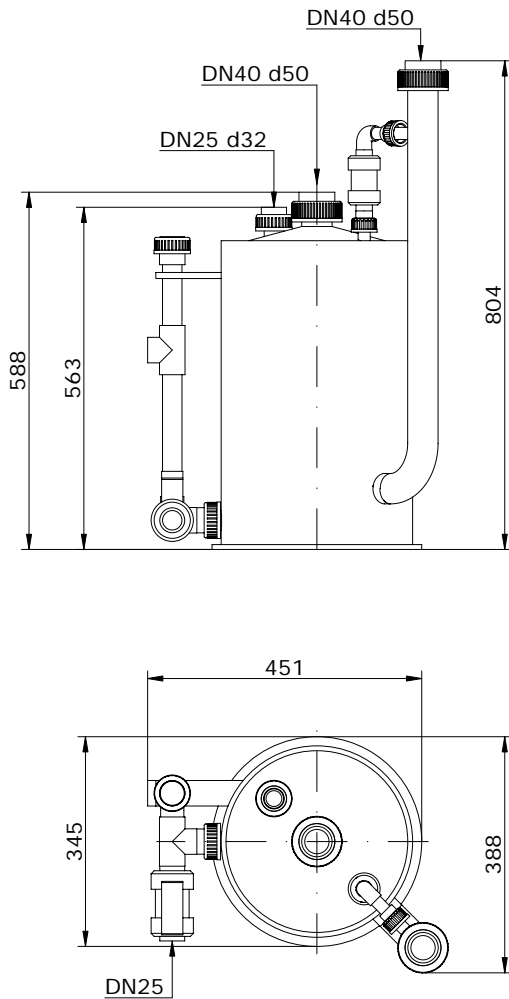

● = Basic design -- = not available ▲ = with add. price Ⓞ = on request ○ = without add. price Art.-Nr. = available as Basic design/ Accessories

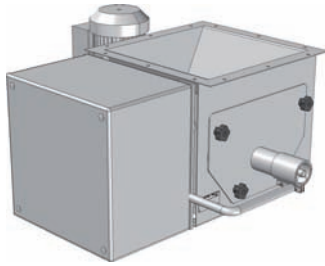

VDS in survey

- Compact design
- Linear performance curves
- For pourable, non-bridging media
- High dosing accuracy
- Mounted-on ribbon pan
- Sealing between filling space and drive
- No-maintenance
- Easy to operate

Infobox

- Resistance chart [Chapter 5](#)
- Installation examples [Chapter 5](#)

Technical data / Order information

Type	Capacity litre/hour	Drive kW	Nom. speed 1/min.	Article-No. Steel	x	Article-No. 1.4571	x
VDS 25/4	0,4 - 4	0,18	1,5 - 15	25000437		25000003	
VDS 25/16	1,6 - 16	0,18	6,8 - 68	25000320		25000717	
VDS 25/30	3 - 30	0,18	6,8 - 68	25000109		25000962	
VDS 40/80	8 - 80	0,18	6,8 - 68	25000248		25000963	
VDS 60/200	20 - 200	0,18	6,8 - 68	25000964		25000965	

Dimensional drawing

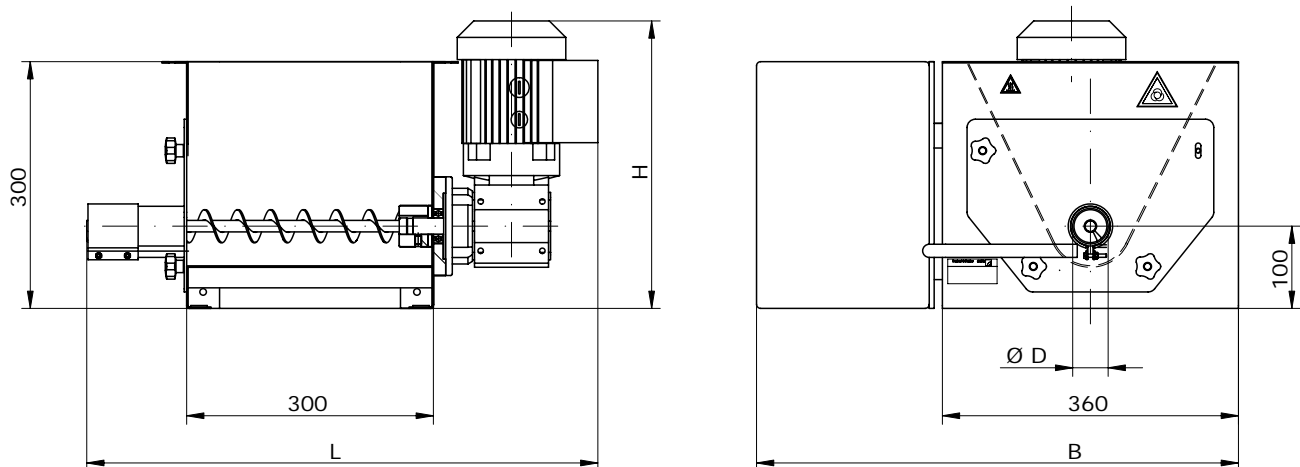

Dimensional chart

All indications in mm

Type	Spiral-Ø / Screw	D	B	L	H
VDS 25/4	25 / 12,5	32	410	625	350
VDS 25/16	25 / 15	32	410	625	350
VDS 25/30	25 / 25	32	410	625	350
VDS 40/80	40 / 40	48	410	625	350
VDS 60/200	60 / 40	68	410	625	350

Options/Accessories			VDS 25/4 ... 60/200	x
Storage hopper with cover	Content: 60 litre	Material: PP	▲	
		Material: Stainless steel	⊙	
Top for storage hopper	Content: 40 litre	Material: PP	▲	
		Material: Stainless steel	—	
Gridiron for storage hopper			▲	
Outer vibrator and vibration damper			▲	
Signal „Hopper empty“	Proximity limit switch, incl. bushing made of PP		▲	

● = Basic design — = not available ▲ = with add. price ⊙ = on request ○ = without add. price Art.-Nr. = available as Basic design/ Accessories

Magneto-inductive flow meter



Magneto-inductive flow meter in survey

- Compact version in field housing
- Digital display
- Menu-driven parameterization
- Systems integration available over HART, PROFIBUS PA and Foundation Fieldbus (option)

Infobox

- Resistance chart [Chapter 5](#)
- Installation examples [Chapter 5](#)

Technical data / Order information

Nominal width	Process connection internal thread	Max. operating pressure * bar	Article-No.	✕
DN 2, DN 4, DN 8	G 3/8	16/40	⊙	
DN 15	G 1/2	16/40	⊙	

The total length depends on the process connection (see Options/Accessories)

* The adm. operating pressure depends on the process connection and sealing:

– 40 bar: Flange, welded joint (with O-Ring-sealings) – 16 bar: Other process connections

Dimensional drawing

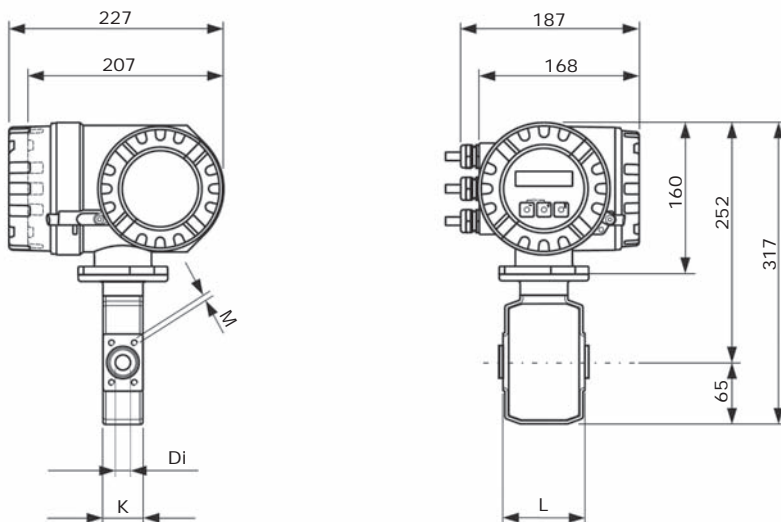

Electrical data	
Protection category	IP 65
Aux. energy	230 V AC
	24 V DC
Output	
Current output 0/4..20mA	
Pulse output (pulse value adjustable)	

Dimensional chart

All indications in mm

Nominal width	Di	K	L	M
DN 2	2,25	43	86	M6 x 4
DN 4	4,5	43	86	M6 x 4
DN 8	9,0	43	86	M6 x 4
DN 15	16,0	43	86	M6 x 4

Options/Accessories		✕
Process connections	Internal thread	●
	External thread	⊙
	Flange connections (different)	⊙
	Welded- or cluedjoint	⊙
	Food & Dairy thread or Tri-Clamp	⊙

● = Basic design – = not available ▲ = with add. price ⊙ = on request ○ = without add. price Art.-Nr. = available as Basic design/ Accessories



Mass flow meter in survey

- Compact version in field housing
- Digital display
- Menu-driven parameterization
- Suitable for continuous measuring, filling and dosing of the smallest rates of flow
- Very exact measurement of liquids and gases
- Systems integration available over HART, PROFIBUS PA and Foundation Fieldbus (option)

Infobox

- Resistance chart [Chapter 5](#)
- Installation examples [Chapter 5](#)

Technical data / Order information

Nominal width	Process connection Flange (EN 1902-1)	Max. operating pressure bar	Flow rate kg/h	Article-No. PP	x
DN 1	DN15	40	0..20	Ⓞ	
DN 2	DN15	40	0..100	Ⓞ	
DN 4	DN15	40	0..450	Ⓞ	
DN 8	DN15	40	0..2000	Ⓞ	

Dimensional drawing

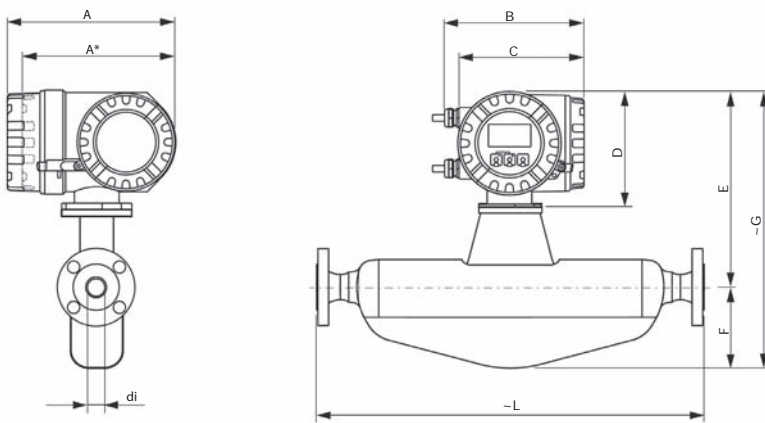

Electrical data	
Protection category	IP 67
Aux. energy	230 V AC
	24 V DC
Output	
Current output 0/4..20mA	
Pulse output (pulse value adjustable)	

Dimensional chart

All indications in mm

Nominal width	di	A	A*	B	C	D	E	F	G	L
DN 1	1,1	227	207	187	168	160	273	32	305	393
DN 2	1,8	227	207	187	168	160	273	32	305	475
DN 4	3,5	227	207	187	168	160	283	32	315	600
DN 8	8,5	227	207	187	168	160	280	104	384	336

Options/Accessories

Options/Accessories		x
Process connections	4-VCO-4 connection (welded)	Ⓞ
	1/2" Tri-Clamp connection (welded)	Ⓞ
	4-VCO-4 connection with mounting-kit: Flange DN 15 EN 1092-1	●
	4-VCO-4 connection with mounting-kit: 1/4" NPT-F	Ⓞ
	4-VCO-4 connection with mounting-kit: 1/8" oder 1/4" SWAGELOK	Ⓞ

● = Basic design -- = not available ▲ = with add. price Ⓞ = on request ○ = without add. price Art.-Nr. = available as Basic design/ Accessories

Calorimetric flow controller



Calorimetric flow controller in survey

- Wide range of application
- High quality materials
- No-maintenance
- No wear
- Robust industrial design
- Processing unit for control cabinet assembly

Infobox

- Resistance chart [Chapter 5](#)
- Installation examples [Chapter 5](#)

Technical data / Order information

Nominal width	Max. operating pressure (at 20°C) bar	Max. operating temperature °C		Adjustment range cm/s	Highest sensitivity cm/s	Protection category	Article-No. PVC-U	Article-No.	
		PVC-U	PP					x	PP
DN 5	10	40	60	3...300	3...60	IP 67	Ⓞ	Ⓞ	
DN 8	10	40	60	3...300	3...60	IP 67	Ⓞ	Ⓞ	
DN 15	10	40	60	3...300	3...60	IP 67	Ⓞ	Ⓞ	
DN 20	10	40	60	3...300	3...60	IP 67	Ⓞ	Ⓞ	
DN 25	10	40	60	3...300	3...60	IP 67	Ⓞ	Ⓞ	

Dimensional drawing

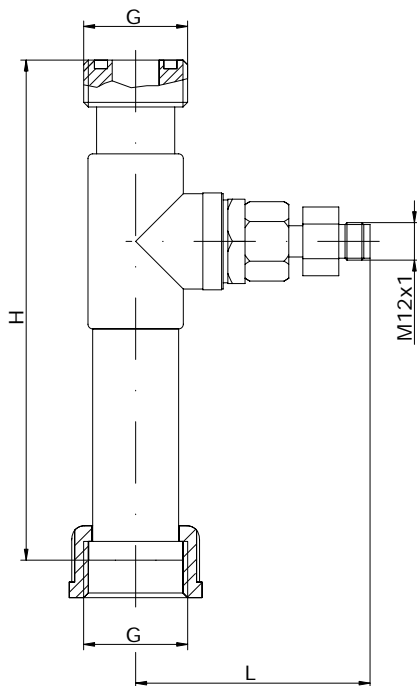

Dimensional chart

All indications in mm

Nominal width	G	H		L	
		PVC-U	PP	PVC-U	PP
DN 5	G 3/4	125	128	79	80
DN 8	G 3/4	125	128	79	80
DN 15	G 1	159	160	75	75
DN 20	G 1 1/4	190	188	80	79
DN 25	G 1 1/2	226	224	88	85

● = Basic design -- = not available ▲ = with add. price Ⓞ = on request ○ = without add. price Art.-Nr. = available as Basic design/ Accessories



Continuous level measuring in survey

- Continuous, non-contacting fill level measuring in liquids, pastes, sludges and coarse-grained bulk materials
- Quick and simple commissioning by menu-driven local operation via four-line plain text display
- Suitable for the use in potentially explosive areas (gas-Ex, dust-Ex)
- Systems integration over HART (standard), 4...20mA PROFIBUS PA, Foundation Fieldbus

Infobox

- Resistance chart [Chapter 5](#)
- Installation examples [Chapter 5](#)

Technical data / Order information

Description	Max. Range		Article-No. Direct current design	x	Article-No. Alternating current design	x
	Fluids	Bulk materials				
Continuous level measuring	5m - 15m	2m - 7m	⊙		⊙	
Basic design Ultrasonic measuring device with display and menu-driven parameterization, process contacting parts made of PVC/EPDM * enclosure IP66, outlet 4...20mA incl. fixing device for mounting on the tank						

* other material designs bzw. Messung für stark ausgasende Medien on request

Dimensional drawing

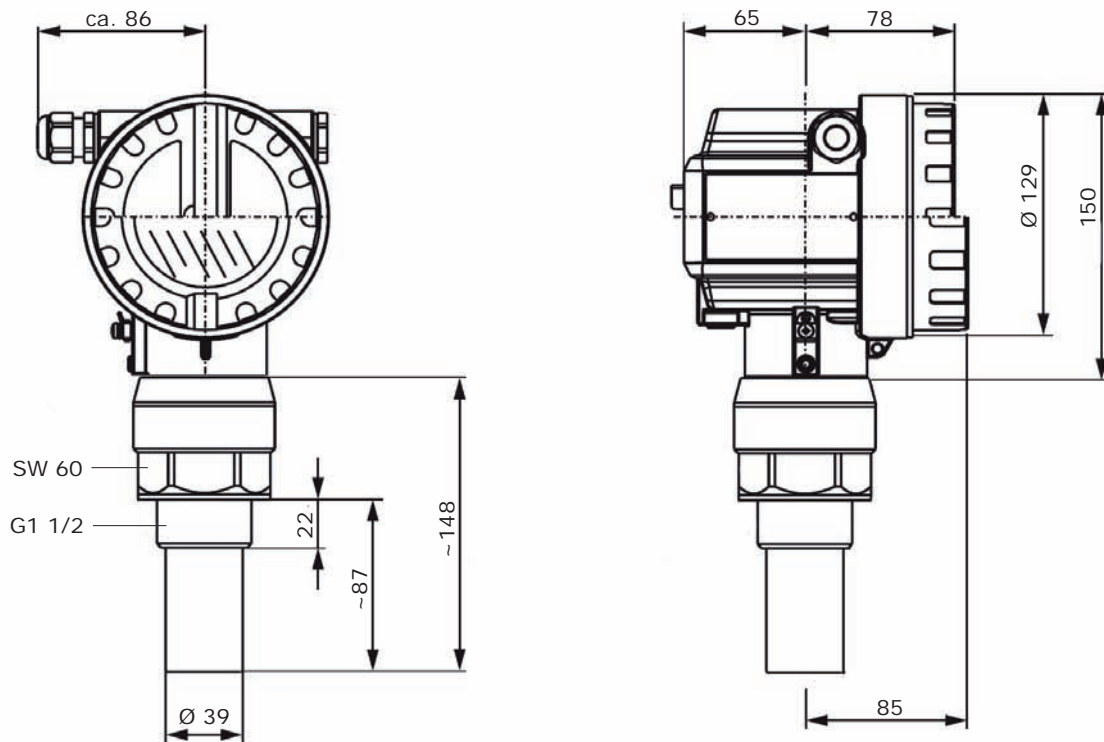

● = Basic design	-- = not available	▲ = with add. price	⊙ = on request	○ = without add. price	Art.-Nr. = available as Basic design/ Accessories
------------------	--------------------	---------------------	----------------	------------------------	---

Filling level meter



Vibration limit switch in survey

- Space saving, compact design
- Robust housing made of stainless steel
- Indication of the switching status as well as test possibility external at the appliance
- Any fitting position
- Enclosure IP65/67/68
- Medium-contacting parts made of stainless steel (1.4571)
- Process connection G 1A

Infobox

- Resistance chart [Chapter 5](#)
- Installation examples [Chapter 5](#)

Technical / Electrical data

Description		Article-No.	x
Alternating current design	19..253 V AC, 2-wire	Ⓞ	
Direct current design	10..55 V DC, 3-wire PNP	Ⓞ	
Hazardous area	19..253 V AC or 10..55 V DC Ex II2G EExde IIC T6	Ⓞ	

Dimensional drawing

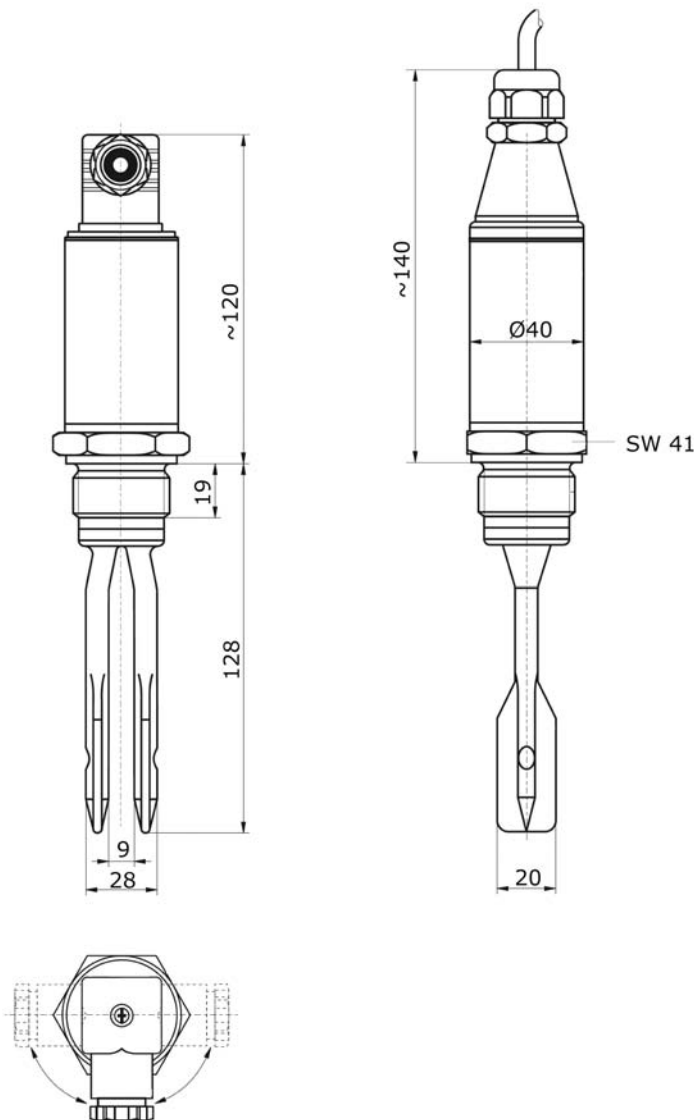

● = Basic design -- = not available ▲ = with add. price Ⓞ = on request ○ = without add. price Art.-Nr. = available as Basic design/Accessories



Capacitive proximity switch in survey

- Height-adjustable fixing device
- Offset angle (90°) possible
- Protection against short circuits, clogged
- Increased interference resistance (for conducted HF)
- Overload-proof
- Reverse polarity protection

Infobox

- Resistance chart [Chapter 5](#)
- Installation examples [Chapter 5](#)

Technical / Electrical data

Description		Article-No.	x
Alternating current design	19..253 V AC, 2-wire	⊙	
Direct current design	10..55 V DC, 3-wire PNP	⊙	
NAMUR-design	Ex II1G EEx ia IIB T4	⊙	

Dimensional drawing

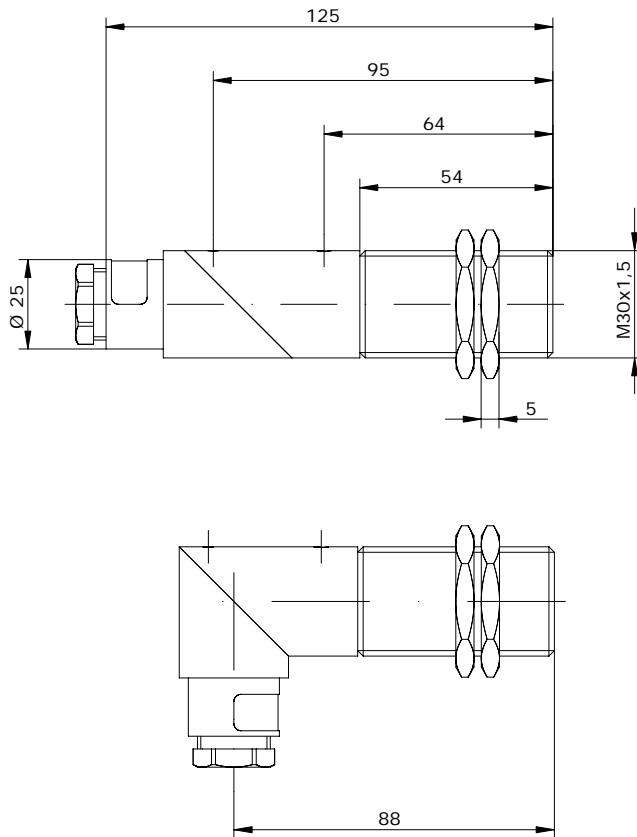

Options/Accessories			x
Extra limit switch	for alternating current design	▲	
	for direct current design	▲	
	for NAMUR-design	▲	
Buffer amplifier acc. to NAMUR for control panel assembly (potential-free output)	Aux. energy 24 V DC	▲	
	Aux. energy 230 V AC	▲	

● = Basic design -- = not available ▲ = with add. price ⊙ = on request ○ = without add. price Art.-Nr. = available as Basic design/ Accessories



pH-measuring in survey

- Fitting for measuring of the pH-value
- pH-one-stick measuring chain, gel, 120 mm
- Model: AH-glass, 0-14 pH
- Temperature range 10-70 °C

Infobox

- Resistance chart [Chapter 5](#)
- Installation examples [Chapter 5](#)

Technical information

- Dip-in fitting for simple applications for one gel-electrode (pH single-rod measuring cell)
- For assembly with the help of hose clamps
- Easily removable due to union nut
- With protective cage for electrode
- Upper end of fitting with PG-screwing for cable entry

Details

- Material of medium-contacting parts: PP
- Working temperature: max. 70° C
- Pipe length: 1000 mm
- Pipe diameter: outside 25 mm
- Minimum immersion depth: 70 mm

Further information on request

Options/Accessories		pH-measuring	x
Dip-in fitting	For the use in open and closed tanks Material: PP, Sealings EPDM Connection: PG 13,5, pressureless, temperature: 10...40°C, Length: 1000 mm	●	
Flow fitting	For the use in a bypass or in a sampling pipe without outlet pressure Material: PVC, Sealings EPDM Connection DN25 clued bushing, max. pressure 4 bar, temperature 10..40 °C	▲	
pH measuring amplifier	<ul style="list-style-type: none"> ■ Measuring range adjustable 0 - 14 pH or -1500 to + 1500 mV ■ Connection for PT100 ■ with digital display and key pad ■ 3 relays (2 switching contacts and alarm contact) ■ Analogue output 0/4..20 mA ■ Aux. energy 230 V AC 	▲	
	<div style="display: flex; justify-content: space-between;"> <div>for control cabinet assembly</div> <div>enclosure IP54 (front)</div> </div>	▲	
	for local assembly	▲	
● = Basic design – = not available ▲ = with add. price ⊗ = on request ○ = without add. price Art.-Nr. = available as Basic design/ Accessories			



Redox-measuring in survey

- Fitting for measuring of the Redox-value
- Redox-one-stick measuring chain, gel, 120 mm
- Model: AH-glass, 0-14 pH
- Temperature range 10-70 °C

Infobox

- Resistance chart [Chapter 5](#)
- Installation examples [Chapter 5](#)

Technical information

- Dip-in fitting for simple applications for one gel-electrode (Redox single-rod measuring cell)
- For assembly with the help of hose clamps
- Easily removable due to union nut
- With protective cage for electrode
- Upper end of fitting with PG-screwing for cable entry

Details

- Material of medium-contacting parts: PP
- Working temperature: max. 70° C
- Pipe length: 1000 mm
- Pipe diameter: outside 25 mm
- Minimum immersion depth: 70 mm

Further information on request

Options/Accessories		Redox-measuring	
Dip-in fitting	For the use in open and closed tanks Material: PP, Sealings EPDM Connection: PG 13,5, pressureless, temperature: 10...40°C, Length: 1000 mm	●	x
Flow fitting	For the use in a bypass or in a sampling pipe without outlet pressure Material: PVC, Sealings EPDM Connection DN25 clued bushing, max. pressure 4 bar, temperature 10..40 °C	▲	
pH measuring amplifier	<ul style="list-style-type: none"> ■ Measuring range adjustable 0 - 14 pH or -1500 to + 1500 mV ■ Connection for PT100 ■ with digital display and key pad ■ 3 relays (2 switching contacts and alarm contact) ■ Analogue output 0/4..20 mA ■ Aux. energy 230 V AC 	▲	
	<div style="display: flex; justify-content: space-between;"> <div>for control cabinet assembly</div> <div>enclosure IP54 (front)</div> </div> <hr/> <div style="display: flex; justify-content: space-between;"> <div>for local assembly</div> <div>enclosure IP65</div> </div>	▲	
<p>● = Basic design -- = not available ▲ = with add. price ⊕ = on request ○ = without add. price Art.-Nr. = available as Basic design/ Accessories</p>			



Chlorine-measuring in survey

- Cl₂ - Electrodes for the determination of dissolved free chlorine

Infobox

- Resistance chart [Chapter 5](#)
- Installation examples [Chapter 5](#)

Technical information

Flow-fitting is for the measuring of free chlorine.
There can be installed to more sensors additionally (e.g. pH, Redox or temperature). Plexiglas, backplate electrode made of stainless steel (1.4571). With Filter and flow transmitter.

Further information on request.

Options/Accessories		chlorine-measuring	x
pH-electrode for automatic pH-compensation	For the use together with a chlorine measuring cell for automatic pH compensation pH-value 0...14, max. pressure 4 bar, temperature 10...70°C, length 120 mm incl. 3m connection cable	▲	
Flow fitting	For the use in a bypass without outlet pressure, Material: Plexiglass System with additional space for two electrodes: backplate electrode made of 1.4571 flow transmitter for flow setting and as low-water alarm, incl. 3 m connection cable for flow transmitter	▲	
chlorine measuring amplifier	<ul style="list-style-type: none"> ■ Measuring range adjustable 0 - 4,0 mg/l ■ connection for PT 100 ■ with digital display and key pad ■ 3 relays (2 switching contacts and alarm contact) ■ analogue output 0/4...20 mA ■ aux. energy 230 V AC 		
	for control cabinet assembly enclosure IP54 (front) for local assembly enclosure IP65	▲	
● = Basic design – = not available ▲ = with add. price ⊗ = on request ○ = without add. price Art.-Nr. = available as Basic design/Accessories			



Universal industry controller in survey

- Industry controller in different designs
 - as continuous controller
 - with two binary control outputs
- For integration in a control cabinet front
- Front hoseproof
- Aux. energy 230 V AC or 24 V DC available
- Device parameterized ready for operation

Infobox

- Resistance chart [Chapter 5](#)
- Installation examples [Chapter 5](#)

Technical data / Order information

Description	Aux. energy	Input signal	Output	Enclosure	Article-No.	x
Universal industry controller Designed as continuous controller	230 V AC	0/4...20 mA	Control output 0/4...20 mA	IP 65	Ⓞ	
Universal industry controller Designed with two binary control outputs*	230 V AC	0/4...20 mA	2 relay outputs	IP 65	Ⓞ	



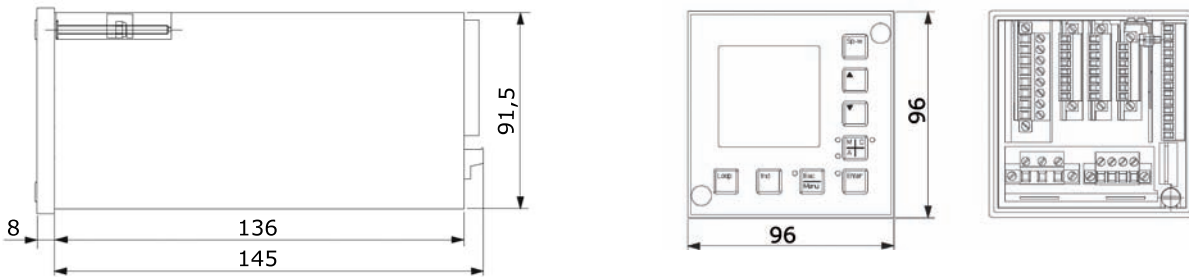



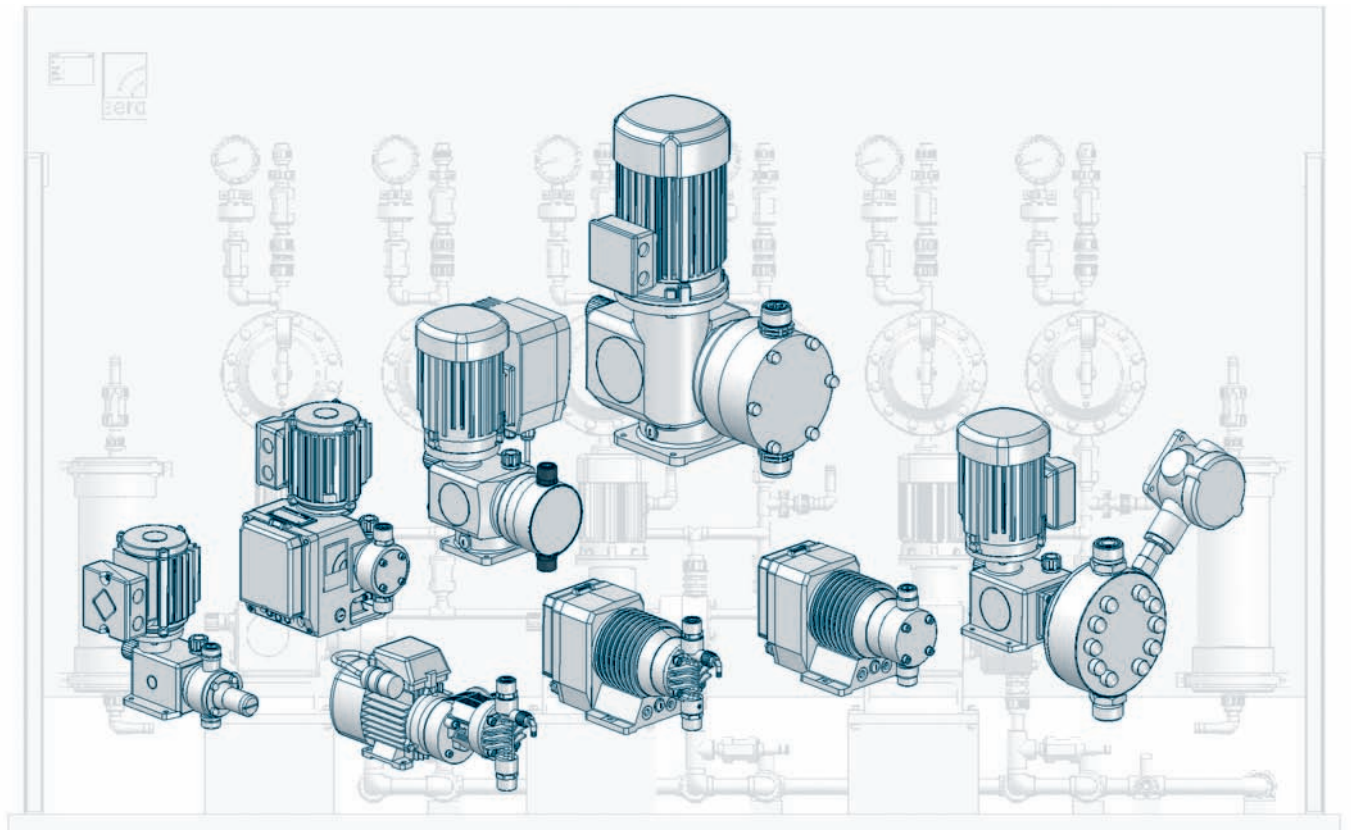

Dimensional drawing



Options/Accessories		x
Universal industry controller Designed as continuous controller	with aux. energy 24 V DC	▲
Universal industry controller Designed with two binary control outputs*	with aux. energy 24 V DC	▲
* e.g. for direct control of an actuator		
● = Basic design – = not available ▲ = with add. price Ⓞ = on request ○ = without add. price Art.-Nr. = available as Basic design/ Accessories		



Dosing- and feeding pumps	Chapter content	Flow capacity	Counter-pressure	Page
Application in laboratory and industry	Controllable solenoid diaphragm pumps and Self-ventilating solenoid diaphragm pumps	1,2 l/h 35 l/h	10 bar 1,5 bar	2.3
	Controllable diaphragm pumps and Self-ventilating diaphragm pumps	18 l/h 350 l/h	10 bar 3 bar	
	Controllable piston diaphragm pumps	6,5 l/h 1500 l/h	50 bar 17 bar	
	Diaphragm pumps	1,2 l/h 35 l/h	10 bar 1,5 bar	
Heavy industrial operating conditions, Ex-zone	Diaphragm pumps	18 l/h 4000 l/h	10 bar 3 bar	2.45
	Diaphragm-multi-headed pumps	2 x 3,75 l/h 3 x 190 l/h	10 bar 4 bar	
	Diaphragm-feeding pumps	450 l/h 3100 l/h	4 bar 2 bar	
	Piston diaphragm pumps	8,5 l/h 1500 l/h	50 bar 8 bar	
	Piston pumps	0,4 l/h 52 l/h	140 bar 20 bar	
	Multi-layer diaphragm pumps	9,0 l/h 600 l/h	20 bar 4 bar	
	Air driven diaphragm pumps	5,0 l/min. 850 l/min.	7,0 bar 0,5 bar	

Dosing- and feeding pumps for applications in laboratory and industry		Series	Flow capacity	Counter pressure	Page
	Controllable Solenoid diaphragm pumps	R 204.1	1,2 l/h ▼ 35 l/h	10 bar ▲ 1,5 bar	2.4
	Controllable Self-ventilating Solenoid diaphragm pumps	RS 204.1	1,2 l/h ▼ 35 l/h	10 bar ▲ 1,5 bar	2.8
	Multifunctional controllable Solenoid diaphragm pumps	C 204.1	1,2 l/h ▼ 35 l/h	10 bar ▲ 1,5 bar	2.12
	Multifunctional controllable Self-ventilating Solenoid diaphragm pumps	CS 204.1	1,2 l/h ▼ 35 l/h	10 bar ▲ 1,5 bar	2.18
	Multifunctional controllable Diaphragm pumps	C 409.2	18 l/h ▼ 350 l/h	10 bar ▲ 3 bar	2.24
	Multifunctional controllable Self-ventilating Diaphragm pumps	CS 409.2	18 l/h ▼ 30 l/h	10 bar	2.30
	Controllable Piston diaphragm pumps	C 409.1 - KM	6,5 l/h ▼ 54 l/h	50 bar ▲ 17 bar	2.36
	Diaphragm pumps	R 302	1,2 l/h ▼ 35 l/h	10 bar ▲ 1,5 bar	2.40

Solenoid diaphragm pumps

Flow capacity 1,2 l/h ... 35 l/h

Admissible counterpressure up to 10 bar



R 204.1



R 204.1 in survey

- Compact design
- Little weight
- Safe to run dry
- Leakage-free
- Low-maintenance
- User-friendly
- High dosing accuracy
- Integrateable into automatic processes
- Digital and analog control possibilities
- Manual stroke length and stroke frequency adjustment
- Robust, corrosion-resistant housing

Infobox

- Order information [Page 2.5](#)
- Options/accessories [Page 2.5](#)
- fittings-allocation [Page 2.7](#)
- connecting pieces [Chapter 4](#)
- resistance chart [Chapter 5](#)
- installation examples [Chapter 5](#)

Functions and operating modes

- Manual operation
- Manual stroke frequency adjustment (10%, 25%, 50%, 100%)
- External STOP
- Pulse operation (1:1)
- Analogue operation (4-20 mA)
- 3 LEDs for status indication
- 2-key operation
- 2 digital inputs (SPS or contact signal)
- 1 analogue input (4-20 mA)
- 2-stage level monitoring
- Voltage 50/60 Hz 100-240 V
- 2m Connecting cable with Euro-plug

Technical data

Type	Nominal capacity		Nominal stroke frequency		Capacity per stroke ml/Hub	Admissible counterpressure bar	Admissible pressure at pump inlet bar	Max. suction height mWS	Inlet/Outlet nominal width DN	Max. stroke length mm	Motor output W
	l/h	l/h	1/min	1/min							
R204.1-1,2e	0 - 1.2	0 - 1.2	150	150	0.13	10	-0.3 / 0	3	5	1.5	20
R204.1-2,4e	0 - 2.4	0 - 2.4	150	150	0.27	10	-0.3 / 0	3	5	1.5	26
R204.1-6,0e	0 - 6	0 - 6	150	150	0.67	6	-0.3 / 0	3	5	1.5	26
R204.1-7,0e	0 - 7	0 - 7	150	150	0.78	10	-0.3 / 0	3	5	1.5	33
R204.1-10e	0 - 10	0 - 10	150	150	1.11	6	-0.3 / 0	3	5	1.5	33
R204.1-14e	0 - 14	0 - 14	150	150	1.56	3	-0.3 / 0	3	5	1.5	26
R204.1-25e	0 - 25	0 - 25	150	150	2.78	3	-0.3 / 0	3	10	1.5	33
R204.1-30e	0 - 30	0 - 30	150	150	3.33	2.5	-0.3 / 0	3	10	1.5	33
R204.1-35e	0 - 35	0 - 35	150	150	3.89	1.5	-0.3 / 0	3	10	1.5	33

Dimensional drawing

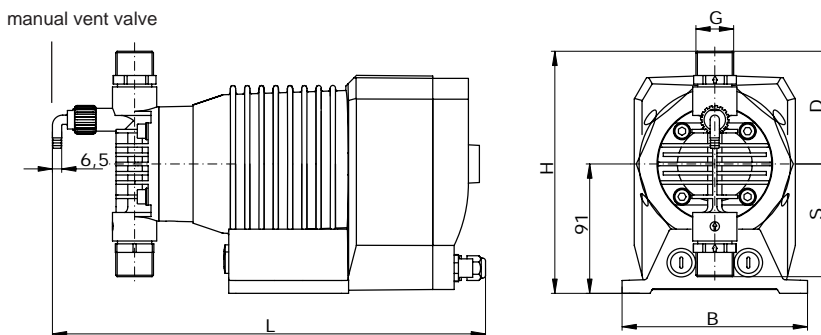

Dimensional chart

All indications in mm

Type	G	S	D	L	B	H	Weight kg
R204.1-1,2e	G 3/4	80	80	305	130	171	2.7
R204.1-2,4e	G 3/4	80	80	305	130	171	3.4
R204.1-6,0e	G 3/4	80	80	305	130	171	3.5
R204.1-7,0e	G 3/4	80	80	305	130	171	4.4
R204.1-10e	G 3/4	80	80	305	130	171	4.4
R204.1-14e	G 3/4	80	80	305	130	171	3.4
R204.1-25e	G 3/4	75	75	265	130	166	4.7
R204.1-30e	G 3/4	75	75	265	130	166	4.7
R204.1-35e	G 3/4	75	75	265	130	166	4.7

Manual vent valve only with PP-FRP und PVDF-FRP design at pumps with a nominal capacity up to 14 l/h

Order information

Basic design



R204.1-1,2e to R204.1-14e

- Pump body PP-FRP
- Double valves PP-FRP
- Valve balls glass
- Valve seals FPM
- Working diaphragm PTFE-faced
- Manual vent valve PP-FRP with hose nozzle (only with pump body made of PP-FRP/PVDF-FRP)

R204.1-25e to R204.1-35e

- Pump body PP-FRP
- Double valves PP-FRP
- Valve balls glass
- Valve seals FPM
- Working diaphragm PTFE-faced
- Further options and accessories**
 - Connection pieces see chapter 4
 - Product documentation see chapter 5

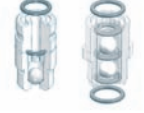
Type	Basic design	x
R204.1-1,2e	16005226	
R204.1-2,4e	16005227	
R204.1-6,0e	16005228	
R204.1-7,0e	16005229	
R204.1-10e	16005230	
R204.1-14e	16005231	
R204.1-25e	16005232	
R204.1-30e	16005233	
R204.1-35e	16005234	

Options/Accessories			R204.1-1,2e up to R204.1-14e	x	R204.1-25e up to R204.1-35e	x
Pump body and valves 	PP-FRP	double valves PP-FRP	●		●	
	PVC-U	single valves PVC-U	–		▲	
		chamber valves (double valves) PVC-U	▲		–	
	PVDF-FRP	double valves PVDF-FRP	▲		⊙	
		1.4571	double valves 1.4571/1.4581	–		⊙
		chamber valves (double valves) 1.4571	⊙		–	
Valve balls 	Glass	single valves	–		○	
		double valves	●		●	
	1.4401	single valves	–		○	
		double valves	○		○	
	PTFE	single valves	–		▲	
		double valves	▲		▲	
Valve sealings 	FPM	single valves	–		○	
		double valves	●		●	
	EPDM	single valves	–		○	
		double valves	○		○	
	FEP-covered	single valves	–		▲	
		double valves	▲		▲	
Console 		1.4301	90023872		90023872	
	for wall mounting incl. fixing screws	PP	90023844		90023844	
Control cable 	M12 cable box 3-pole, 5 meter für level input (Level monitor not included)		90022888		90022888	
	M12 cable box 3-pole, ready-made for level input (Level monitor not included)		90022877		90022877	
	M12 cable box 5-pole, 5 meter for impulse and analogue signal		90022887		90022887	
Special connection 	Special connection (plug) für power supply		⊙		⊙	

● = Basic design ▲ = with add. price ○ = without add. price ⊙ = on request – = not available Art.-Nr. = available in basic design/accessories

Order information

Basic design

R204.1-1,2e to R204.1-14e

- Pump body PP-FRP
- Double valves PP-FRP
- Valve balls glass
- Valve seals FPM
- working diaphragm PTFE-faced
- Manual vent valve PP-FRP with hose nozzle (only with pump body made of PP-FRP/PVDF-FRP)

R204.1-25e to R204.1-35e

- Pump body PP-FRP
 - Double valves PP-FRP
 - Valve balls glass
 - Valve seals FPM
 - Working diaphragm PTFE-faced
- Further options and accessories**
- Connection pieces see chapter 4
 - Product documentation see chapter 5

Type	Basic design	x
R204.1-1,2e	16005226	
R204.1-2,4e	16005227	
R204.1-6,0e	16005228	
R204.1-7,0e	16005229	
R204.1-10e	16005230	
R204.1-14e	16005231	
R204.1-25e	16005232	
R204.1-30e	16005233	
R204.1-35e	16005234	

Options/Accessories

Dosing kit

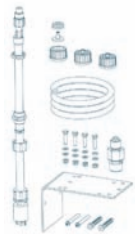

Dosing kit - Level switch 1-stage
cons. of:
1 Pc. SL-11.1, PVC-U, glass-balls, 600 mm, plug M12
3 Pc. Hose screwings for PVC-hose
10 m. PVC-hose 6/12
1 Pc. Dosing valve 691.1, PP/PP-FRP, EPDM, PTFE, 1 bar
1 Pc. Console 1.4301 incl. fixing screws

Option:
SL-11.1 - 1000 mm

Option:
Dosing valve 691.1, PVC-U, EPDM, PTFE, 1 bar

Dosing kit - Level switch 2-stage
cons. of:
1 Pc. SL-12.1, PVC-U, glass-balls, 600 mm, plug M12
3 Pc. Hose screwings for PVC-hose
10 m. PVC-hose 6/12
1 Pc. Dosing valve 691.1, PP/PP-FRP, EPDM, PTFE, 1 bar
1 Pc. Console 1.4301 incl. fixing screws

Option:
SL-12.1 - 1000 mm

Option:
Dosing valve 691.1, PVC-U, EPDM, PTFE, 1 bar

	R204.1-1,2e up to R204.1-14e	x	R204.1-25e up to R204.1-35e	x
	37602656		37602656	
	▲		▲	
	▲		▲	
	37602658		37602658	
	▲		▲	
	▲		▲	

● =Basic design ▲ = with add. price ○ = without add. price ⊗ = on request - = not available Art.-Nr. = available in basic design/accessories

Fittings for suction side of dosing pumps		R204.1-1,2e R204.1-2,4e		R204.1-6,0e up to R204.1-35e	
		Type	p.	Type	p.
Suction lance	with level switch 1-stage	SL-11.1	3.36	SL-11.1	3.36
	with level switch 2-stage	SL-12.1	3.36	SL-12.1	3.36
	without level switch	S-01	3.42	S-01	3.42
Priming aid	transparent PVC-U	769.1	3.72	769.1	3.72
Suction aid / Siphon Vessel	transparent PVC-U	770.2	3.74	770.2	3.74
Calibration Pot	PVC-U	791.1	3.76	792.1	3.76
Foot valve	PVC-U	731	3.78	731	3.78
	PP-FRP / PVDF-FRP	781.1	3.82	781.1	3.82
	1.4571	731	3.78	731	3.78
Line strainer	PVC-U	751.1	3.84	751.1	3.84
	PVC-U / PP / PVDF	752.1	3.84	752.1	3.84
	1.4408	752	3.86	752	3.86
Float valve	PVC-U	871	3.88	871	3.88
Pulsation damper without separating diaphragm	PVC-U / PP	702.1	3.14	702.1	3.14
	1.4571	802.1	3.18	802.1	3.18
Fittings for pressure side of dosing pumps		R204.1-1,2e R204.1-2,4e		R204.1-6,0e up to R204.1-35e	
		Type	p.	Type	p.
Diaphragm-type relief valve		620.10	3.4	620.10	3.4
Diaphragm-type pressure keeping valve		620.D	3.8	620.D	3.8
Multi-function valve	4 bar opening pressure	MFV 05004	3.10	MFV 05004	3.10
	6 bar opening pressure	MFV 05006	3.10	MFV 05006	3.10
	10 bar opening pressure	MFV 05010	3.10	MFV 05010	3.10
Pulsation damper without separating diaphragm	PVC-U / PP	702.1	3.14	702.1	3.14
	1.4571	802.1	3.18	802.1	3.18
Diaphragm-pulsation damper with PTFE/PTFE-faced diaphragm	PVC-U / PP / PVDF	720.1	3.24	720.1	3.24
	1.4571	721.1	3.28	721.1	3.28
Diaphragm-pulsation damper with Elastomer-diaphragm	1.4571	810.1-0,16/180	3.30	810.1-0,16/180	3.30
Check valve	PVC-U	661.2	3.48	661.2	3.48
	PP-FRP / PVDF-FRP	661.2	3.48	661.2	3.48
	1.4571	661.2	3.48	661.2	3.48
Dosing valve	PVC-U	691.1	3.54	691.1	3.54
	PVC-U / PP / PVDF	681.1	3.58	681.1	3.58
	PP-FRP / PVDF-FRP	691.1	3.54	691.1	3.54
	1.4571	691.1	3.54	691.1	3.54
Injection fitting	PVC-U / PP / PVDF	8061.1	3.60	8061.1	3.60

The above allocation considers the fittings which have to be used at least regarding their nominal width in order to ensure the safe and trouble-free operation of the respective pumps when feeding liquids which are resembling to water.

Absolutely note the max. admissible operating pressure of the fittings.

The use of fittings of a bigger nominal width is unproblematically possible in most cases.

When choosing the fittings note the installation instructions for dosing pumps or confer with s e r a .

Self ventilating solenoid diaphragm pumps

Flow capacity 1,2 l/h ... 35 l/h

Admissible counterpressure up to 10 bar



RS204.1



RS 204.1 in survey

- Self-ventilating
- Compact design
- Little weight
- Safe to run dry
- Leakage-free
- Low-maintenance
- User-friendly
- High dosing accuracy
- Integrateable into automatic processes
- Digital and analog control possibilities
- Manual stroke length and stroke frequency adjustment
- Robust, corrosion-resistant housing

Infobox

- Order information [Page 2.9](#)
- Options/accessories [Page 2.9](#)
- fittings-allocation [Page 2.11](#)
- connecting pieces [Chapter 4](#)
- resistance chart [Chapter 5](#)
- installation examples [Chapter 5](#)

Functions and operating modes

- Manual operation
- Manual stroke frequency adjustment (10%, 25%, 50%, 100%)
- External STOP
- Pulse operation (1:1)
- Analogue operation (4-20 mA)
- 3 LEDs for status indication
- 2-key operation
- 2 digital inputs (SPS or contact signal)
- 1 analogue input (4-20 mA)
- 2-stage level monitoring
- Automatic self-ventilating
- Voltage 190-240 V, 50/60 Hz
- Voltage 100-120 V, 50 Hz
- Voltage 100-120 V, 60 Hz
- 2m Connecting cable with Euro-plug

Technical data

Type	Nominal capacity		Nominal stroke frequency		Capacity per stroke ml/Hub	Admissible counter-pressure bar	Admissible pressure at pump inlet bar	Max. suction height mWS	Inlet nominal width DN	Inlet/ Outlet nominal width DN	Max. stroke length mm	Motor output W
	l/h	l/min	1/min	1/min								
RS204.1-1,2e	0 - 1.2	0 - 1.2	150	150	0.13	10	-0.15 / 0	1.5	4	5	1.5	20
RS204.1-2,4e	0 - 2.4	0 - 2.4	150	150	0.27	10	-0.2 / 0	2	4	5	1.5	26
RS204.1-6,0e	0 - 6	0 - 6	150	150	0.67	6	-0.3 / 0	3	4	5	1.5	26
RS204.1-7,0e	0 - 7	0 - 7	150	150	0.78	10	-0.3 / 0	3	4	5	1.5	33
RS204.1-10e	0 - 10	0 - 10	150	150	1.11	6	-0.3 / 0	3	4	5	1.5	33
RS204.1-14e	0 - 14	0 - 14	150	150	1.56	3	-0.3 / 0	3	4	5	1.5	26
RS204.1-25e	0 - 25	0 - 25	150	150	2.78	3	-0.3 / 0	3	5	10	1.5	33
RS204.1-30e	0 - 30	0 - 30	150	150	3.33	2.5	-0.3 / 0	3	5	10	1.5	33
RS204.1-35e	0 - 35	0 - 35	150	150	3.89	1.5	-0.3 / 0	3	5	10	1.5	33

Dimensional drawing

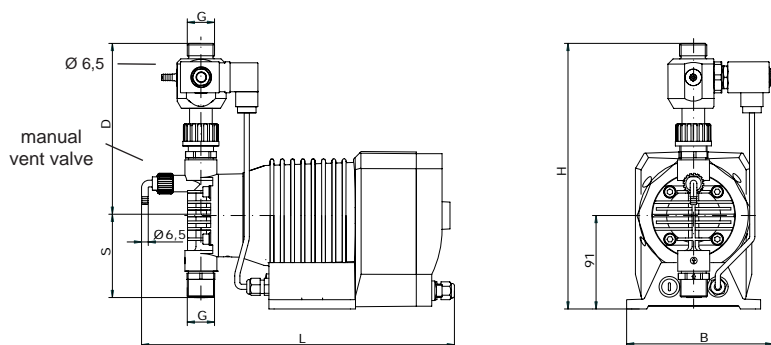

Dimensional chart

All indications in mm

Type	G	S	D	L	B	H	Weight kg
RS204.1-1,2e	G 3/4	80	168	305	143	248	3.1
RS204.1-2,4e	G 3/4	80	168	305	143	248	3.8
RS204.1-6,0e	G 3/4	80	168	305	143	248	3.9
RS204.1-7,0e	G 3/4	80	168	305	143	248	4.8
RS204.1-10e	G 3/4	80	168	305	143	248	4.8
RS204.1-14e	G 3/4	80	168	305	143	248	3.8
RS204.1-25e	G 3/4	75	163	265	143	243	5.1
RS204.1-30e	G 3/4	75	163	265	143	243	5.1
RS204.1-35e	G 3/4	75	163	265	143	243	5.1

Manual vent valve only with PP-FRP und PVDF-FRP design at pumps with a nominal capacity from 6 l/h up to 14 l/h

Order information

Basic design

RS204.1-1,2e to RS204.1-2,4e

- Pump body PP
- Chamber valves PP
- Valve balls glass
- Valve seals FPM
- working diaphragm PTFE-faced
- automatic vent valve PP

RS204.1-6,0e to RS204.1-14e

- Pump body PP-FRP
- Double valves PP-FRP
- Valve balls glass
- Valve seals FPM

- working diaphragm PTFE-faced
- automatic vent valve PP





RS204.1-25e to RS204.1-35e

- Pump body PP-FRP
- Double valves PP-FRP
- Valve balls glass
- Valve seals FPM
- Working diaphragm PTFE-faced

Further options and accessories

- Connection pieces see chapter 4
- Product documentation see chapter 5

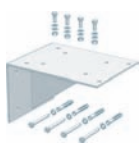
Type	Basic design	x
RS204.1-1,2e	16005246	
RS204.1-2,4e	16005247	
RS204.1-6,0e	16005248	
RS204.1-7,0e	16005249	
RS204.1-10e	16005250	
RS204.1-14e	16005251	
RS204.1-25e	16005252	
RS204.1-30e	16005253	
RS204.1-35e	16005254	

Options/Accessories			RS204.1-1,2e RS204.1-2,4e	x	RS204.1-6,0e up to RS204.1-14e	x	RS204.1-25e up to RS204.1-35e	x	
Pump body and valves 	PP	chamber valves (double valves) PP	●		–		–		
	PP-FRP	double valves PP-FRP	–		●		●		
	PVC-U	single valves PVC-U		–		–		▲	
		chamber valves (double valves) PVC-U		▲		▲		–	
	PVDF	Chamber valves (double valves) PVDF		▲		–		–	
	PVDF-FRP	double valves PVDF-FRP		–		▲		⊗	
Valve balls 	Glass	single valves	–		–		○		
		double valves	●		●		●		
	1.4401	single valves		–		–		○	
		double valves		○		○		○	
	PTFE	single valves		–		–		▲	
		double valves		–		–		▲	
Valve sealings 	FPM	single valves	–		–		○		
		double valves	●		●		●		
	EPDM	single valves		–		–		○	
		double valves		○		○		○	
	FEP-covered	single valves		–		–		▲	
		double valves		▲		▲		▲	
Console 		1.4301	90023872		90023872		90023872		
	for wall mounting incl. fixing screws	PP	90023844		90023844		90023844		
Control cable 	M12 cable box 3-pole, 5 meter für level input (Level monitor not included)		90022888		90022888		90022888		
	M12 cable box 3-pole, ready-made for level input (Level monitor not included)		90022877		90022877		90022877		
	M12 cable box 5-pole, 5 meter for impulse and analogue signal		90022887		90022887		90022887		
Special connection 	Special connection (plug) für power supply		⊗		⊗		⊗		

● = Basic design ▲ = with. add price ○ = without add. price ⊗ = on request – = not available Art.-Nr. = available in basic design/ accessories

Order information

Basic design

RS204.1-1,2e to RS204.1-2,4e

- Pump body PP
- Chamber valves PP
- Valve balls glass
- Valve seals FPM
- working diaphragm PTFE-faced
- automatic vent valve PP

RS204.1-6,0e to RS204.1-14e

- Pump body PP-FRP
- Double valves PP-FRP
- Valve balls glass
- Valve seals FPM

- working diaphragm PTFE-faced
- automatic vent valve PP

RS204.1-25e to RS204.1-35e

- Pump body PP-FRP
- Double valves PP-FRP
- Valve balls glass
- Valve seals FPM
- Working diaphragm PTFE-faced

Further options and accessories

- Connection pieces see chapter 4
- Product documentation see chapter 5

Type	Basic design	x
RS204.1-1,2e	16005246	
RS204.1-2,4e	16005247	
RS204.1-6,0e	16005248	
RS204.1-7,0e	16005249	
RS204.1-10e	16005250	
RS204.1-14e	16005251	
RS204.1-25e	16005252	
RS204.1-30e	16005253	
RS204.1-35e	16005254	

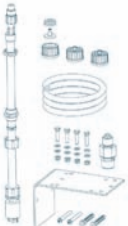
Options/Accessories		RS204.1-1,2e RS204.1-2,4e	x	RS204.1-6,0e up to RS204.1-14e	x	RS204.1-25e up to RS204.1-35e	x
 <p>Dosing kit</p> <p>Dosing kit - Level switch 1-stage cons. of: 1 Pc. SL-11.1, PVC-U, glass-balls, 600 mm, plug M12 3 Pc. Hose screwings for PVC-hose 10 m. PVC-hose 6/12 1 Pc. Dosing valve 691.1, PP/PP-FRP, EPDM, PTFE, 1 bar 1 Pc. Console 1.4301 incl. fixing screws</p> <p>Option: SL-11.1 - 1000 mm</p> <p>Option: Dosing valve 691.1, PVC-U, EPDM, PTFE, 1 bar</p>	37602656		37602656		37602656		
	▲		▲		▲		
	▲		▲		▲		
	▲		▲		▲		
<p>Dosing kit - Level switch 2-stage cons. of: 1 Pc. SL-12.1, PVC-U, glass-balls, 600 mm, plug M12 3 Pc. Hose screwings for PVC-hose 10 m. PVC-hose 6/12 1 Pc. Dosing valve 691.1, PP/PP-FRP, EPDM, PTFE, 1 bar 1 Pc. Console 1.4301 incl. fixing screws</p> <p>Option: SL-12.1 - 1000 mm</p> <p>Option: Dosing valve 691.1, PVC-U, EPDM, PTFE, 1 bar</p>	37602658		37602658		37602658		
	▲		▲		▲		
	▲		▲		▲		
	▲		▲		▲		

● = Basic design ▲ = with. add price ○ = without add. price ⊗ = on request -- = not available Art.-Nr. = available in basic design/ accessories

2

Fittings for suction side of dosing pumps		RS204.1-1,2e RS204.1-2,4e		RS204.1-6,0e up to RS204.1-35e	
		Type	p.	Type	p.
Suction lance	with level switch 1-stage	SL-11.1	3.36	SL-11.1	3.36
	with level switch 2-stage	SL-12.1	3.36	SL-12.1	3.36
	without level switch	S-01	3.42	S-01	3.42
Priming aid	transparent PVC-U	769.1	3.72	769.1	3.72
Suction aid / Siphon Vessel	transparent PVC-U	770.2	3.74	770.2	3.74
Calibration Pot	PVC-U	791.1	3.76	792.1	3.76
Foot valve	PVC-U	731	3.78	731	3.78
	PP-FRP / PVDF-FRP	781.1	3.82	781.1	3.82
	1.4571	731	3.78	731	3.78
Line strainer	PVC-U	751.1	3.84	751.1	3.84
	PVC-U / PP / PVDF	752.1	3.84	752.1	3.84
	1.4408	752	3.86	752	3.86
Float valve	PVC-U	871	3.88	871	3.88
Pulsation damper without separating diaphragm	PVC-U / PP	702.1	3.14	702.1	3.14
	1.4571	802.1	3.18	802.1	3.18
Fittings for pressure side of dosing pumps		RS204.1-1,2e RS204.1-2,4e		RS204.1-6,0e up to RS204.1-35e	
		Type	p.	Type	p.
Diaphragm-type relief valve		620.10	3.4	620.10	3.4
Diaphragm-type pressure keeping valve		620.D	3.8	620.D	3.8
Multi-function valve	4 bar opening pressure	MFV 05004	3.10	MFV 05004	3.10
	6 bar opening pressure	MFV 05006	3.10	MFV 05006	3.10
	10 bar opening pressure	MFV 05010	3.10	MFV 05010	3.10
Pulsation damper without separating diaphragm	PVC-U / PP	702.1	3.14	702.1	3.14
	1.4571	802.1	3.18	802.1	3.18
Diaphragm-pulsation damper with PTFE/PTFE-faced diaphragm	PVC-U / PP / PVDF	720.1	3.24	720.1	3.24
	1.4571	721.1	3.28	721.1	3.28
Diaphragm-pulsation damper with Elastomer-diaphragm	1.4571	810.1-0,16/180	3.30	810.1-0,16/180	3.30
Check valve	PVC-U	661.2	3.48	661.2	3.48
	PP-FRP / PVDF-FRP	661.2	3.48	661.2	3.48
	1.4571	661.2	3.48	661.2	3.48
Dosing valve	PVC-U	691.1	3.54	691.1	3.54
	PVC-U / PP / PVDF	681.1	3.58	681.1	3.58
	PP-FRP / PVDF-FRP	691.1	3.54	691.1	3.54
	1.4571	691.1	3.54	691.1	3.54
Injection fitting	PVC-U / PP / PVDF	8061.1	3.60	8061.1	3.60

The above allocation considers the fittings which have to be used at least regarding their nominal width in order to ensure the safe and trouble-free operation of the respective pumps when feeding liquids which are resembling to water.

Absolutely note the max. admissible operating pressure of the fittings.

The use of fittings of a bigger nominal width is unproblematically possible in most cases.

When choosing the fittings note the installation instructions for dosing pumps or confer with s e r a.



C 204.1 in survey

- Compact design
- Little weight
- Safe to run dry
- Leakage-free
- Low-maintenance
- User-friendly
- High dosing accuracy
- Multifunctional
- Digital and analog control possibilities
- Manual stroke length and stroke frequency adjustment
- Robust, corrosion-resistant housing

Infobox

- Order information [Page 2.13](#)
- Options/accessories [Page 2.13](#)
- fittings-allocation [Page 2.16](#)
- connecting pieces [Chapter 4](#)
- resistance chart [Chapter 5](#)
- installation examples [Chapter 5](#)

Functions and operating modes

- Manual operation
- Manual stroke frequency adjustment
- Profibus® DP - Interface*
- External START/STOP
- Pulse operation / fractinator
- Cycle delay unit
- Pulse fractionator
- Analogue operation (4-20 mA)
- Analogue operation standardization
- Charge manual/with timer
- 3 LED's for status indicator
- Multiline illuminated text display
- Menu - driven parameterization
- Flow indication
- Calibration
- 4 - key operation
- 2 digital outputs (SPS)
- 1 digital input (SPS or contact signal)
- 2 analogue / digital inputs (optionally reversible)
- Programmable input-/output functions
- Connection / evaluation 2-stage level monitoring
- Connection / evaluation diaphragm rupture monitoring
- Connection / evaluation flow monitoring
- Connection / evaluation flow metering
- Voltage 100 - 240 V, 50/60 Hz
- 2m Connecting cable with Euro-plug

Technical data

Type	Nominal capacity		Nominal stroke frequency		Capacity per stroke ml/Hub	Admissible counter-pressure bar	Admissible pressure at pump inlet bar	Max. suction height mWS	Inlet/ Outlet nominal width DN	Max. stroke length mm	Motor output W
	l/h		1/min								
	50 Hz	60 Hz	50 Hz	60 Hz							
C204.1-1,2e	0 - 1.2	0 - 1.2	150	150	0.13	10	-0.3 / 0	3	5	1.5	20
C204.1-2,4e	0 - 2.4	0 - 2.4	150	150	0.22	10	-0.3 / 0	3	5	1.5	26
C204.1-6,0e	0 - 6	0 - 6	150	150	0.66	6	-0.3 / 0	3	5	1.5	26
C204.1-7,0e	0 - 7	0 - 7	150	150	0.77	10	-0.3 / 0	3	5	1.5	33
C204.1-10e	0 - 10	0 - 10	150	150	1.1	6	-0.3 / 0	3	5	1.5	33
C204.1-14e	0 - 14	0 - 14	150	150	1.5	3	-0.3 / 0	3	5	1.5	26
C204.1-25e	0 - 25	0 - 25	150	150	2.7	3	-0.3 / 0	3	10	1.5	33
C204.1-30e	0 - 30	0 - 30	150	150	3.3	2.5	-0.3 / 0	3	10	1.5	33
C204.1-35e	0 - 35	0 - 35	150	150	3.8	1.5	-0.3 / 0	3	10	1.5	33

Dimensional drawing

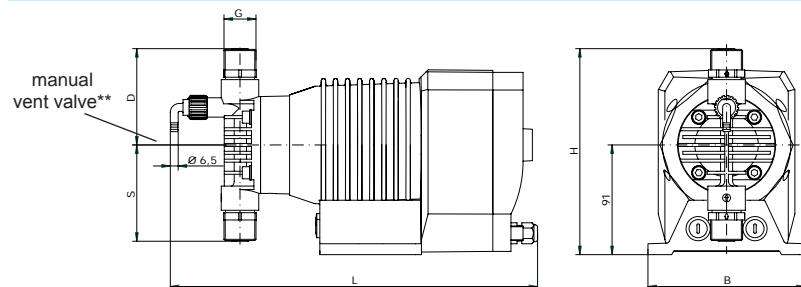

Dimensional chart

All indications in mm

Type	G	S	D	L	B	H	Weight kg
C204.1-1,2e	G 3/4	80	80	305	130	171	2.7
C204.1-2,4e	G 3/4	80	80	305	130	171	3.4
C204.1-6,0e	G 3/4	80	80	305	130	171	3.5
C204.1-7,0e	G 3/4	80	80	305	130	171	4.4
C204.1-10e	G 3/4	80	80	305	130	171	4.4
C204.1-14e	G 3/4	80	80	305	130	171	3.4
C204.1-25e	G 3/4	75	75	265	130	166	4.7
C204.1-30e	G 3/4	75	75	265	130	166	4.7
C204.1-35e	G 3/4	75	75	265	130	166	4.7

* Available at the second half of 2007

**Manual vent valve only with PP-FRP und PVDF-FRP design at pumps with a nominal capacity up to 14 l/h

Order information

Basic design





C204.1-1,2e to C204.1-14

- Pump body PP-FRP
- Double valves PP-FRP
- Valve balls glass
- Valve seals FPM
- Working diaphragm PTFE-faced
- Manual vent valve PP-FRP with hose nozzle (only with pump body made of PP-FRP/PVDF-FRP)
- Control cable 8-pole

C204.1-25e to C204.1-35e

- Pump body PP-FRP
- Double valves PP-FRP
- Valve balls glass
- Valve seals FPM
- Working diaphragm PTFE-faced
- Control cable 8-pole
- Further options and accessories**
- Connection pieces see chapter 4
- Product documentation see chapter 5

Type	Basic design	x
C204.1-1,2e	16005236	
C204.1-2,4e	16005237	
C204.1-6,0e	16005238	
C204.1-7,0e	16005239	
C204.1-10e	16005240	
C204.1-14e	16005241	
C204.1-25e	16005242	
C204.1-30e	16005243	
C204.1-35e	16005244	

Options/Accessories			C204.1-1,2e up to C204.1-14e	x	C204.1-25e up to C204.1-35e	x
Pump body and valves 	PP-FRP	double valves PP-FRP	●		●	
	PVC-U	single valves PVC-U	–		▲	
		chamber valves (double valves) PVC-U	▲		–	
	PVDF-FRP	double valves PVDF-FRP	▲		⊙	
		1.4571	double valves 1.4571/1.4581	–		⊙
		chamber valves (double valves) 1.4571	⊙		–	
Valve balls 	Glass	single valves	–		○	
		double valves	●		●	
	1.4401	single valves	–		○	
		double valves	○		○	
	PTFE	single valves	–		▲	
double valves		▲		▲		
Valve sealings 	FPM	single valves	–		○	
		double valves	●		●	
	EPDM	single valves	–		○	
		double valves	○		○	
	FEP-covered	single valves	▲		▲	
		double valves	▲		▲	
Diaphragm rupture monitoring 	Diaphragm rupture electrode conductive, mounted to pump					
		MBE-02	▲		▲	
Flow controller 	IP65 incl. cable 0,6 m and cable box M12 5-pole (bushing for pump connection) Material valve seals: FPM Connection: Input: G 3/4 (Inlet), output: G 3/4 (outlet) Max. permissible operating pressure: 10 bar					
	8191.1	PVC-U/FPM	37602227		–	
		PP/FPM	37602175		–	
	8192.1	PVC-U/FPM	–		37602176*	
		PP/FPM	–		37602177*	
*Compare the application of the flow controller with the stroke volume of the pump which is to be set, use type 8191.1, if necessary (note the indications in the data sheet)						
● = Basic design ▲ = with add. price ○ = without add. price ⊙ = on request – = not available Art.-Nr. = available in basic design/accessories						

Order information

Basic design



C204.1-1,2e to C204.1-14

- Pump body PP-FRP
- Double valves PP-FRP
- Valve balls glass
- Valve seals FPM
- Working diaphragm PTFE-faced
- Manual vent valve PP-FRP with hose nozzle (only with pump body made of PP-FRP/PVDF-FRP)
- Control cable 8-pole

C204.1-25e to C204.1-35e

- Pump body PP-FRP
 - Double valves PP-FRP
 - Valve balls glass
 - Valve seals FPM
 - working diaphragm PTFE-faced
 - Control cable 8-pole
- Further options and accessories**
- Connection pieces see chapter 4
 - Product documentation see chapter 5

Type	Basic design	x
C204.1-1,2e	16005236	
C204.1-2,4e	16005237	
C204.1-6,0e	16005238	
C204.1-7,0e	16005239	
C204.1-10e	16005240	
C204.1-14e	16005241	
C204.1-25e	16005242	
C204.1-30e	16005243	
C204.1-35e	16005244	

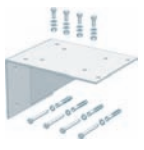
Options/Accessories		C204.1-1,2e up to C204.1-14e	x	C204.1-25e up to C204.1-35e	x
 <p>Flow meter*</p> <p>IP65 incl. cable 0,6m and cable box M12 5-pole (bushing for pump connection) Connection: Inlet: G 3/4 (inside); Outlet G 3/4 (outside) Max. operating pressure: 8 bar</p>	8010.1	ECTFE/PP/FPM	37602337	–	
		ECTFE/PVC-U/FPM	37602339	–	
		ECTFE/PVDF/FPM	37602341	–	
	8011.1	ECTFE/PP/FPM	–	37602343	
		ECTFE/PVC-U/FPM	–	37602345	
		ECTFE/PVDF/FPM	–	37602348	
*Note the indications in the data sheet					
 <p>Special connection</p> <p>Special connection (plug) für power supply</p>			⊗	⊗	
 <p>Control cable</p> <p>M12 cable box 3-pole, 5 meter für level input (Level monitor not included)</p>			90022888	90022888	
				90022877	90022877
 <p>Console</p> <p>for wall mounting incl. fixing screws</p>	1.4301		90023872	90023872	
	PP		90023844	90023844	
<p>● = Basic design ▲ = with add. price ○ = without add. price ⊗ = on request – = not available Art.-Nr. = available in basic design/accessories</p>					

Order information

Basic design

C204.1-1,2e to C204.1-14

- Pump body PP-FRP
- Double valves PP-FRP
- Valve balls glass
- Valve seals FPM
- Working diaphragm PTFE-faced
- Manual vent valve PP-FRP with hose nozzle (only with pump body made of PP-FRP/PVDF-FRP)
- Control cable 8-pole

C204.1-25e to C204.1-35e

- Pump body PP-FRP
- Double valves PP-FRP
- Valve balls glass
- Valve seals FPM
- working diaphragm PTFE-faced
- Control cable 8-pole
- Further options and accessories**
- Connection pieces see chapter 4
- Product documentation see chapter 5

Type	Basic design	x
C204.1-1,2e	16005236	
C204.1-2,4e	16005237	
C204.1-6,0e	16005238	
C204.1-7,0e	16005239	
C204.1-10e	16005240	
C204.1-14e	16005241	
C204.1-25e	16005242	
C204.1-30e	16005243	
C204.1-35e	16005244	

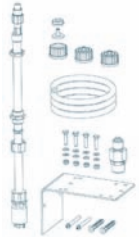
Options/Accessories		C204.1-1,2e up to C204.1-14e	x	C204.1-25e up to C204.1-35e	x
 <p>Dosing kit</p>	Dosing kit - Level switch 1-stage cons. of: 1 Pc. SL-11.1, PVC-U, glass-balls, 600 mm, plug M12 3 Pc. Hose screwings for PVC-hose 10 m. PVC-hose 6/12 1 Pc. Dosing valve 691.1, PP/PP-FRP, EPDM, PTFE, 1 bar 1 Pc. Console 1.4301 incl. fixing screws	37602656		37602656	
	Option: SL-11.1 - 1000 mm	▲		▲	
	Option: Dosing valve 691.1, PVC-U, EPDM, PTFE, 1 bar	▲		▲	
	Dosing kit - Level switch 2-stage cons. of: 1 Pc. SL-12.1, PVC-U, glass-balls, 600 mm, plug M12 3 Pc. Hose screwings for PVC-hose 10 m. PVC-hose 6/12 1 Pc. Dosing valve 691.1, PP/PP-FRP, EPDM, PTFE, 1 bar 1 Pc. Console 1.4301 incl. fixing screws	37602658		37602658	
	Option: SL-12.1 - 1000 mm	▲		▲	
	Option: Dosing valve 691.1, PVC-U, EPDM, PTFE, 1 bar	▲		▲	
● = Basic design ▲ = with add. price ○ = without add. price ⊕ = on request -- = not available Art.-Nr. = available in basic design/accessories					

Fittings for suction side of dosing pumps			C204.1-1,2e C204.1-2,4e		C204.1-6,0e up to C204.1-35e	
			Type	p.	Type	p.
Suction lance	with level switch 1-stage	SL-11.1	3.36	SL-11.1	3.36	
	with level switch 2-stage	SL-12.1	3.36	SL-12.1	3.36	
	without level switch	S-01	3.42	S-01	3.42	
Priming aid	transparent PVC-U	769.1	3.72	769.1	3.72	
Suction aid / Siphon Vessel	transparent PVC-U	770.2	3.74	770.2	3.74	
Calibration Pot	PVC-U	791.1	3.76	792.1	3.76	
Foot valve	PVC-U	731	3.78	731	3.78	
	PP-FRP / PVDF-FRP	781.1	3.82	781.1	3.82	
	1.4571	731	3.78	731	3.78	
Line strainer	PVC-U	751.1	3.84	751.1	3.84	
	PVC-U / PP / PVDF	752.1	3.84	752.1	3.84	
	1.4408	752	3.86	752	3.86	
Float valve	PVC-U	871	3.88	871	3.88	
Pulsation damper without separating diaphragm	PVC-U / PP	702.1	3.14	702.1	3.14	
	1.4571	802.1	3.18	802.1	3.18	
Fittings for pressure side of dosing pumps			C204.1-1,2e C204.1-2,4e		C204.1-6,0e up to C204.1-35e	
			Type	p.	Type	p.
Diaphragm-type relief valve			620.10	3.4	620.10	3.4
Diaphragm-type pressure keeping valve			620.D	3.8	620.D	3.8
Multi-function valve	4 bar opening pressure	MFV 05004	3.10	MFV 05004	3.10	
	6 bar opening pressure	MFV 05006	3.10	MFV 05006	3.10	
	10 bar opening pressure	MFV 05010	3.10	MFV 05010	3.10	
Pulsation damper without separating diaphragm	PVC-U / PP	702.1	3.14	702.1	3.14	
	1.4571	802.1	3.18	802.1	3.18	
Diaphragm-pulsation damper with PTFE/PTFE-faced diaphragm	PVC-U / PP / PVDF	720.1	3.24	720.1	3.24	
	1.4571	721.1	3.28	721.1	3.28	
Diaphragm-pulsation damper with Elastomer-diaphragm	1.4571	810.1- 0,16/180	3.30	810.1- 0,16/180	3.30	
Check valve	PVC-U	661.2	3.48	661.2	3.48	
	PP-FRP / PVDF-FRP	661.2	3.48	661.2	3.48	
	1.4571	661.2	3.48	661.2	3.48	
Dosing valve	PVC-U	691.1	3.54	691.1	3.54	
	PVC-U / PP / PVDF	681.1	3.58	681.1	3.58	
	PP-FRP / PVDF-FRP	691.1	3.54	691.1	3.54	
	1.4571	691.1	3.54	691.1	3.54	
Injection fitting	PVC-U / PP / PVDF	8061.1	3.60	8061.1	3.60	

The above allocation considers the fittings which have to be used at least regarding their nominal width in order to ensure the safe and trouble-free operation of the respective pumps when feeding liquids which are resembling to water.

Absolutely note the max. admissible operating pressure of the fittings.

The use of fittings of a bigger nominal width is unproblematically possible in most cases.

When choosing the fittings note the installation instructions for dosing pumps or confer with s e r a.

Self-ventilating controllable solenoid diaphragm pumps

Flow capacity 1,2 l/h ... 35 l/h

Admissible counterpressure up to 10 bar



CS204.1



CS204.1 in survey

- Self-ventilating
- Compact design
- Little weight
- Safe to run dry
- Leakage-free
- Low-maintenance
- User-friendly
- High dosing accuracy
- Multifunctional
- Manual stroke length and stroke frequency adjustment
- Robust, corrosion-resistant housing

Infobox

- Order information [Page 2.19](#)
- Options/accessories [Page 2.19](#)
- fittings-allocation [Page 2.22](#)
- connecting pieces [Chapter 4](#)
- resistance chart [Chapter 5](#)
- installation examples [Chapter 5](#)

Functions and operating modes

- Manual operation
- Manual stroke frequency adjustment
- Profibus® DP - Interface*
- External START/STOP
- Pulse operation / fractinator
- Cycle delay unit
- Analogue operation (4-20 mA)
- Analogue operation standardization
- Charge manual/with timer
- 3 LED's für status indicator
- Multiline illuminated text display
- Menu - driven parameterization
- Flow indication
- Calibration
- 4 - key operation
- 2 digital outputs (SPS)
- 1 digital input (SPS or contact signal)
- 2 analogue / digital inputs (optionally reversible)
- Programmable input-/output functions
- Connection / evaluation 2-stage level monitoring
- Connection / evaluation diaphragm rupture monitoring
- Connection / evaluation flow monitoring
- Connection / evaluation flow metering
- Automatic self-ventilating
- Voltage 190 - 240 V, 50/60 Hz
- Voltage 100 - 120 V, 50 Hz
- Voltage 100 - 120 V , 60 Hz
- 2m connecting cable with Euro-plug

Technical data

Type	Nominal capacity		Nominal stroke frequency		Capacity per stroke ml/Hub	Admissible counter-pressure bar	Admissible pressure at pump inlet bar	Max. suction height mWS	Inlet nominal width DN	Inlet/ Outlet nominal width DN	Max. stroke length mm	Motor output W
	50 Hz	60 Hz	50 Hz	60 Hz								
CS204.1-1,2e	0 - 1.2	0 - 1.2	150	150	0.13	10	-0.15 / 0	1.5	4	5	1.5	20
CS204.1-2,4e	0 - 2.4	0 - 2.4	150	150	0.22	10	-0.2 / 0	2	4	5	1.5	26
CS204.1-6,0e	0 - 6	0 - 6	150	150	0.66	6	-0.3 / 0	3	4	5	1.5	26
CS204.1-7,0e	0 - 7	0 - 7	150	150	0.78	10	-0.3 / 0	3	4	5	1.5	33
CS204.1-10e	0 - 10	0 - 10	150	150	1.1	6	-0.3 / 0	3	4	5	1.5	33
CS204.1-14e	0 - 14	0 - 14	150	150	1.5	3	-0.3 / 0	3	4	5	1.5	26
CS204.1-25e	0 - 25	0 - 25	150	150	2.7	3	-0.3 / 0	3	5	10	1.5	33
CS204.1-30e	0 - 30	0 - 30	150	150	3.3	2.5	-0.3 / 0	3	5	10	1.5	33
CS204.1-35e	0 - 35	0 - 35	150	150	3.8	1.5	-0.3 / 0	3	5	10	1.5	33

Dimensional drawing

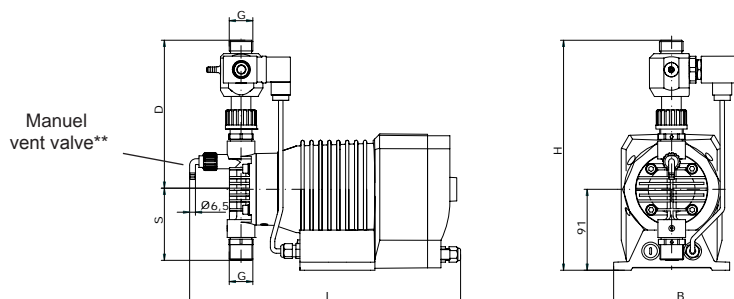

Dimensional chart

All indications in mm

Type	G	S	D	L	B	H	Weight kg
CS204.1-1,2e	G 3/4	80	168	305	143	248	3.1
CS204.1-2,4e	G 3/4	80	168	305	143	248	3.4
CS204.1-6,0e	G 3/4	80	168	305	143	248	3.9
CS204.1-7,0e	G 3/4	80	168	305	143	248	4.8
CS204.1-10e	G 3/4	80	168	305	143	248	4.8
CS204.1-14e	G 3/4	80	168	305	143	248	3.8
CS204.1-25e	G 3/4	75	163	265	143	243	5.1
CS204.1-30e	G 3/4	75	163	265	143	243	5.1
CS204.1-35e	G 3/4	75	163	265	143	243	5.1

* Available at the second half of 2007

** Manual vent valve only with PP-FRP or and PVDF-FRP design at pumps with a nominal capacity from 6 l/h up to 14 l/h

Order information

Basic design

CS204.1-1,2e to CS204.1-2,4e

- Pump body PP
- Chamber valves PP
- Valve balls glass
- Valve seals FPM
- Working diaphragm PTFE-faced
- Automatic vent valve PP
- Control cable 8-pole

CS204.1-1,2e to CS204.1-14e

- Pump body PP-FRP
- Double valves PP-FRP
- Valve balls glass
- Valve seals FPM
- Working diaphragm PTFE-faced
- Automatic vent valve PP
- Control cable 8-pole





CS204.1-25e to CS204.1-35e

- Pump body PP-FRP
- Double valves PP-FRP
- Valve balls glass
- Valve seals FPM
- Working diaphragm PTFE-faced
- Automatic vent valve PP
- Control cable 8-pole

Further options and accessories

- Connection pieces see chapter 4
- Product documentation see chapter 5

Type	Basic design	x
CS204.1-1,2e	16005255	
CS204.1-2,4e	16005256	
CS204.1-6,0e	16005257	
CS204.1-7,0e	16005258	
CS204.1-10e	16005259	
CS204.1-14e	16005260	
CS204.1-25e	16005261	
CS204.1-30e	16005262	
CS204.1-35e	16005263	

Options/Accessories			CS204.1-1,2e CS204.1-2,4e	x	CS204.1-6,0e up to CS204.1-14e	x	CS204.1-25e up to CS204.1-35e	x
Pump body and valves 	PP	chamber valves (double valves) PP	●		–		–	
	PP-FRP	double valves PP-FRP	–		●		●	
	PVC-U	single valves PVC-U	–		–		▲	
		chamber valves (double valves) PVC-U	▲		▲		–	
	PVDF	chamber valves (double valves) PVDF	▲		–		–	
	PVDF-FRP	double valves PVDF-FRP	–		▲		⊗	
Valve balls 	Glass	single valves	–		–		○	
		double valves	●		●		●	
	1.4401	single valves	–		–		○	
		double valves	○		○		○	
	PTFE	single valves	–		–		▲	
		double valves	▲		▲		▲	
Valve sealings 	FPM	single valves	–		–		○	
		double valves	●		●		●	
	EPDM	single valves	–		–		○	
		double valves	○		○		○	
	FEP-covered	single valves	–		–		▲	
		double valves	▲		▲		▲	
Diaphragm rupture monitoring 	Diaphragm rupture electrode conductive, mounted to pump							
		MBE-02	▲		▲		▲	
Console 		1.4301	90023872		90023872		90023872	
		for wall mounting incl. fixing screws	PP	90023844		90023844		90023844
● = Basic design ▲ = with add. price ○ = without add. price ⊗ = on request – = not available Art.-Nr. = available in basic design/accessories								

Order information

Basic design

CS204.1-1,2e to CS204.1-2,4e

- Pump body PP
- Chamber valves PP
- Valve balls glass
- Valve seals FPM
- Working diaphragm PTFE-faced
- Automatic vent valve PP
- Control cable 8-pole

CS204.1-1,2e to CS204.1-14e

- Pump body PP-FRP
- Double valves PP-FRP
- Valve balls glass
- Valve seals FPM
- Working diaphragm PTFE-faced
- Automatic vent valve PP
- Control cable 8-pole

CS204.1-25e to CS204.1-35e

- Pump body PP-FRP
- Double valves PP-FRP
- Valve balls glass
- Valve seals FPM
- Working diaphragm PTFE-faced
- Automatic vent valve PP
- Control cable 8-pole

Further options and accessories

- Connection pieces see chapter 4
- Product documentation see chapter 5

Type	Basic design	x
CS204.1-1,2e	16005255	
CS204.1-2,4e	16005256	
CS204.1-6,0e	16005257	
CS204.1-7,0e	16005258	
CS204.1-10e	16005259	
CS204.1-14e	16005260	
CS204.1-25e	16005261	
CS204.1-30e	16005262	
CS204.1-35e	16005263	

Options/Accessories

CS204.1-1,2e
CS204.1-2,4e x

CS204.1-6,0e
up to
CS204.1-14e x

CS204.1-25e
up to
CS204.1-35e x

Flow controller



IP65
incl. cable 0,6 m and cable box M12 5-pole (bushing for pump connection)
Material valve seals: FPM
Connection:
Input: G 3/4 (Inlet), output: G 3/4 (outlet)
Max. permissible operating pressure: 10 bar

8191.1	PVC-U/FPM	37602227		37602227		–	
	PP/FPM	37602175		37602175			
8192.1	PVC-U/FPM	–		–		37602176*	
	PP/FPM	–		–		37602177*	

*Compare the application of the flow controller with the stroke volume of the pump which is to be set, use type 8191.1, if necessary (note the indications in the data sheet)

Flow meter*



IP65
incl. cable 0,6m and cable box M12 5-pole (bushing for pump connection)
Connection:
Inlet: G 3/4 (inside); Outlet G 3/4 (outside)
Max. operating pressure: 8 bar

8010.1	ECTFE/PP/FPM	37602337		37602337		–	
	ECTFE/PVC-U/FPM	37602339		37602339		–	
	ECTFE/PVDF/FPM	37602341		37602341		–	
8011.1	ECTFE/PP/FPM	–		–		37602343	
	ECTFE/PVC-U/FPM	–		–		37602345	
	ECTFE/PVDF/FPM	–		–		37602348	

*Note the indications in the data sheet

Special connection



Special connection (plug)
für power supply

Ⓞ

Ⓞ

Ⓞ

Control cable



M12 cable box 3-pole, 5 meter für level input
(Level monitor not included)

90022888

90022888

90022888

M12 cable box 3-pole, ready-made for level input
(Level monitor not included)

90022877

90022877

90022877

● = Basic design ▲ = with add. price ○ = without add. price Ⓞ = on request – = not available Art.-Nr. = available in basic design/accessories

Order information

Basic design

CS204.1-1,2e to CS204.1-2,4e

- Pump body PP
- Chamber valves PP
- Valve balls glass
- Valve seals FPM
- Working diaphragm PTFE-faced
- Automatic vent valve PP
- Control cable 8-pole

CS204.1-1,2e to CS204.1-14e

- Pump body PP-FRP
- Double valves PP-FRP
- Valve balls glass
- Valve seals FPM
- Working diaphragm PTFE-faced
- Automatic vent valve PP
- Control cable 8-pole

CS204.1-25e to CS204.1-35e

- Pump body PP-FRP
- Double valves PP-FRP
- Valve balls glass
- Valve seals FPM
- Working diaphragm PTFE-faced
- Automatic vent valve PP
- Control cable 8-pole

Further options and accessories

- Connection pieces see chapter 4
- Product documentation see chapter 5

Type	Basic design	x
CS204.1-1,2e	16005255	
CS204.1-2,4e	16005256	
CS204.1-6,0e	16005257	
CS204.1-7,0e	16005258	
CS204.1-10e	16005259	
CS204.1-14e	16005260	
CS204.1-25e	16005261	
CS204.1-30e	16005262	
CS204.1-35e	16005263	

Options/Accessories

Dosing kit

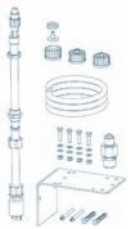

Dosing kit - Level switch 1-stage
cons. of:
1 Pc. SL-11.1, PVC-U, glass-balls, 600 mm, plug M12
3 Pc. Hose screwings for PVC-hose
10 m. PVC-hose 6/12
1 Pc. Dosing valve 691.1, PP/PP-FRP, EPDM, PTFE, 1 bar
1 Pc. Console 1.4301 incl. fixing screws

Option:
SL-11.1 - 1000 mm

Option:
Dosing valve 691.1, PVC-U, EPDM, PTFE, 1 bar

Dosing kit - Level switch 2-stage
cons. of:
1 Pc. SL-12.1, PVC-U, glass-balls, 600 mm, plug M12
3 Pc. Hose screwings for PVC-hose
10 m. PVC-hose 6/12
1 Pc. Dosing valve 691.1, PP/PP-FRP, EPDM, PTFE, 1 bar
1 Pc. Console 1.4301 incl. fixing screws

Option:
SL-12.1 - 1000 mm

Option:
Dosing valve 691.1, PVC-U, EPDM, PTFE, 1 bar

CS204.1-1,2e CS204.1-2,4e	CS204.1-6,0e up to CS204.1-14e	CS204.1-25e up to CS204.1-35e
37602656	37602656	37602656
▲	▲	▲
▲	▲	▲
37602658	37602658	37602658
▲	▲	▲
▲	▲	▲

● = Basic design ▲ = with add. price ○ = without add. price ⊗ = on request – = not available Art.-Nr. = available in basic design/accessories

Fittings for suction side of dosing pumps			CS204.1-1,2e CS204.1-2,4e		CS204.1-6,0e up to CS204.1-35e	
			Type	p.	Type	p.
Suction lance	with level switch 1-stage	SL-11.1	3.36	SL-11.1	3.36	
	with level switch 2-stage	SL-12.1	3.36	SL-12.1	3.36	
	without level switch	S-01	3.42	S-01	3.42	
Priming aid	transparent PVC-U	769.1	3.72	769.1	3.72	
Suction aid / Siphon Vessel	transparent PVC-U	770.2	3.74	770.2	3.74	
Calibration Pot	PVC-U	791.1	3.76	792.1	3.76	
	PVC-U	731	3.78	731	3.78	
Foot valve	PP-FRP / PVDF-FRP	781.1	3.82	781.1	3.82	
	1.4571	731	3.78	731	3.78	
	PVC-U	751.1	3.84	751.1	3.84	
Line strainer	PVC-U / PP / PVDF	752.1	3.84	752.1	3.84	
	1.4408	752	3.86	752	3.86	
	PVC-U	871	3.88	871	3.88	
Float valve	PVC-U	871	3.88	871	3.88	
	PVC-U / PP	702.1	3.14	702.1	3.14	
Pulsation damper without separating diaphragm	1.4571	802.1	3.18	802.1	3.18	
Fittings for pressure side of dosing pumps			CS204.1-1,2e CS204.1-2,4e		CS204.1-6,0e up to CS204.1-35e	
			Type	p.	Type	p.
Diaphragm-type relief valve			620.10	3.4	620.10	3.4
Diaphragm-type pressure keeping valve			620.D	3.8	620.D	3.8
Multi-function valve	4 bar opening pressure	MFV 05004	3.10	MFV 05004	3.10	
	6 bar opening pressure	MFV 05006	3.10	MFV 05006	3.10	
	10 bar opening pressure	MFV 05010	3.10	MFV 05010	3.10	
Pulsation damper without separating diaphragm	PVC-U / PP	702.1	3.14	702.1	3.14	
	1.4571	802.1	3.18	802.1	3.18	
Diaphragm-pulsation damper with PTFE/PTFE-faced diaphragm	PVC-U / PP / PVDF	720.1	3.24	720.1	3.24	
	1.4571	721.1	3.28	721.1	3.28	
Diaphragm-pulsation damper with Elastomer-diaphragm	1.4571	810.1-0,16/180	3.30	810.1-0,16/180	3.30	
Check valve	PVC-U	661.2	3.48	661.2	3.48	
	PP-FRP / PVDF-FRP	661.2	3.48	661.2	3.48	
	1.4571	661.2	3.48	661.2	3.48	
Dosing valve	PVC-U	691.1	3.54	691.1	3.54	
	PVC-U / PP / PVDF	681.1	3.58	681.1	3.58	
	PP-FRP / PVDF-FRP	691.1	3.54	691.1	3.54	
	1.4571	691.1	3.54	691.1	3.54	
Injection fitting	PVC-U / PP / PVDF	8061.1	3.60	8061.1	3.60	

The above allocation considers the fittings which have to be used at least regarding their nominal width in order to ensure the safe and trouble-free operation of the respective pumps when feeding liquids which are resembling to water.

Absolutely note the max. admissible operating pressure of the fittings.

The use of fittings of a bigger nominal width is unproblematically possible in most cases.

When choosing the fittings note the installation instructions for dosing pumps or confer with s e r a.



C409.2 in survey

- Compact design
- Low weight
- Safe if run dry
- Leakage free
- Low maintenance
- Easy to use
- High dosing accuracy
- Multifunctional
- Flexible
- Manual stroke length and stroke frequency adjustment
- Robust metallic housing

Infobox

- Order information [Page 2.25](#)
- Options/accessories [Page 2.25](#)
- fittings-allocation [Page 2.29](#)
- connecting pieces [Chapter 4](#)
- resistance chart [Chapter 5](#)
- installation examples [Chapter 5](#)

Functions and operating modes

- Manual operation
- Manual stroke frequency adjustment
- Profibus® DP - Interface*
- External START/STOP
- Pulse operation / fractinator
- Cycle delay unit
- Analogue operation (0/4-20 mA)
- Analogue operation standardization
- Charge manual/with timer
- Speed control / Slow mode
- 3 LED's for status indication
- Multiline illuminated text display
- Menu - driven parameterization
- Flow indication
- Calibration
- 4 - key operation
- 2 digital outputs (SPS)
- 1 digital input (SPS or contact signal)
- 2 analogue / digital inputs (optionally reversible)
- Programmable input/output functions
- Connection / evaluation 2-stage level monitoring
- Connection / evaluation diaphragm rupture monitoring
- Connection / evaluation flow monitoring
- Connection / evaluation flow metering
- Voltage 210 - 250 V, 50/60 Hz
- 2m connecting cable with Euro-plug

Technical data

Type	Nominal capacity		Nominal stroke frequency		Capacity per stroke	Admissible counter-pressure	Admissible pressure at pump inlet	Max. suction height	Inlet/ Outlet nominal width	Max. stroke length	Motor output
	l/h		1/min								
	50 Hz	60 Hz	50 Hz	60 Hz							
C409.2-18e	0 - 18	0 - 18	100	100	3	10	-0.3 / 0	3	10	6	0.18
C409.2-25e	0 - 25	0 - 25	150	150	3	10	-0.3 / 0	3	10	6	0.18
C409.2-50e	0 - 50	0 - 50	100	100	8.3	10	-0.3 / 0	3	10	8	0.18
C409.2-75e	0 - 75	0 - 75	150	150	8.3	10	-0.3 / 0	3	15	8	0.37
C409.2-90e	0 - 90	0 - 90	100	100	15	8	-0.3 / 0	3	15	10	0.37
C409.2-115e	0 - 115	0 - 115	100	100	19.8	4	-0.3 / 0	3	15	10	0.37
C409.2-140e	0 - 140	0 - 140	150	150	15	6	-0.3 / 0	3	15	10	0.37
C409.2-180e	0 - 180	0 - 180	150	150	19.8	4	-0.3 / 0	3	15	10	0.37
C409.2-250e	0 - 250	0 - 250	100	100	38.8	3	-0.3 / 0	3	15	10	0.37
C409.2-350e	0 - 350	0 - 350	150	150	38.8	3	-0.3 / 0	3	15	10	0.37

e in type designation means: pump with single diaphragm / Smaller capacities of series C409.2 on request

Dimensional drawing

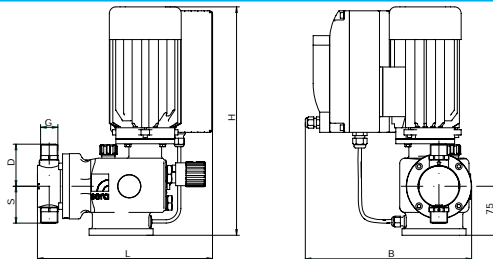

Dimensional chart

All indications in mm

Type	G	S	D	L	B	H	Weight kg
C409.2-18e	G 3/4	56	64	270	250	380	12.6
C409.2-25e	G 3/4	56	64	270	250	380	12.6
C409.2-50e	G 3/4	69	69	270	250	380	12.4
C409.2-75e	G 3/4	69	69	270	250	380	12.4
C409.2-90e	G 3/4	76	76	275	255	380	14.5
C409.2-115e	G 3/4	76	76	275	255	380	13
C409.2-140e	G 3/4	76	76	275	255	380	14.5
C409.2-180e	G 3/4	76	76	275	255	380	13
C409.2-250e	G 1 1/4	122	122	330	285	380	17
C409.2-350e	G 1 1/4	122	122	330	285	380	17

* available at the second half of 2007

Order information

Basic design

C409.2-18e to C409.2-25e

- Pump body PP-FRP
- Double valves PP-FRP
- Valve balls glass
- Valve seals FPM
- Working diaphragm PTFE-faced
- Control cable 8-pole

C409.2-50e to C409.2-90e and C409.2-140e

- Pump body PP-FRP
- Double valves PP-FRP
- Valve balls glass
- Valve seals FPM
- Working diaphragm PTFE-faced
- Control cable 8-pole

C409.2-115e and C409.2-180e

- Pump body PP-FRP
- Single valve PP-FRP
- Valve balls glass
- Valve seals FPM
- Working diaphragm EPDM
- Control cable 8-pole

C409.2-250e und C409.2-350e

- Pump body PP
- Single valve PP-FRP
- Valve balls glass
- Valve seals FPM
- Working diaphragm PTFE-faced
- Control cable 8-pole





Motor:

- 210-250V, 50/60Hz, 1~, IP55, ISO F

Further options and accessories

- Connection pieces see chapter 4
- Product documentation see chapter 5

Type	Basic design	x
C409.2-18e	16005272	
C409.2-25e	16005273	
C409.2-50e	16005274	
C409.2-75e	16005275	
C409.2-90e	16005276	
C409.2-115e	16005277	
C409.2-140e	16005278	
C409.2-180e	16005279	
C409.2-250e	16005288	
C409.2-350e	16005289	

Options/Accessories			C409.2-18e	C409.2-50e	C409.2-90e	C409.2-115e	C409.2-250e
			C409.2-25e	C409.2-75e	C409.2-140e	C409.2-180e	C409.2-350e
Pump body and valves 	PP-FRP	single valves PP-FRP	–	●	●	●	–
		double valves PP-FRP	●	○	○	○	–
	PP	single valves PP-FRP	–	–	–	–	●
		PVC-U	single valves PVC-U	▲	▲	▲	▲
	PVDF-FRP	single valves PVDF-FRP	–	▲	▲	▲	–
		double valves PVDF-FRP	▲	▲	▲	▲	–
	PVDF	single valves PVDF-FRP	–	–	–	–	▲
		double valves PVDF-FRP	–	–	–	–	▲
1.4571	single valves 1.4571/1.4581	–	–	–	–	▲	
	double valves 1.4571/1.4581	▲	▲	▲	▲	▲	
Valve balls 	Glass	single valves	○	●	●	●	●
		double valves	●	○	○	○	○
	1.4401	single valves	–	○	○	○	▲
		double valves	○	○	○	○	▲
PTFE	single valves	–	▲	▲	▲	▲	
	double valves	▲	▲	▲	▲	●	
Valve sealings 	FPM	single valves	–	●	●	●	●
		double valves	●	○	○	○	○
	EPDM	single/double valves	○	○	○	○	●
		FEP-covered	single/double valves	●	●	●	●
Integrated relief valve 	with PTFE-faced diaphragm, connection seal FPM or EPDM at pump body made of:						
	PP	PP	▲	▲	▲	▲	▲
		PVC-U	▲	▲	▲	▲	▲
		PVDF	⊗	⊗	⊗	⊗	⊗
		1.4571	▲	▲	▲	▲	▲
		Connection seals FEP-covered	▲	▲	▲	▲	▲

● = Basic design ○ = without add. price ▲ = with add. price ⊗ = on request – = not available Art.-Nr. = available in basic design/accessories

Order information

Basic design

C409.2-18e to C409.2-25e

- Pump body PP-FRP
- Double valves PP-FRP
- Valve balls glass
- Valve seals FPM
- Working diaphragm PTFE-faced
- Control cable 8-pole

C409.2-50e to C409.2-90e and C409.2-140e

- Pump body PP-FRP
- Double valves PP-FRP
- Valve balls glass
- Valve seals FPM
- Working diaphragm PTFE-faced
- Control cable 8-pole

C409.2-115e and C409.2-180e

- Pump body PP-FRP
- Single valve PP-FRP
- Valve balls glass
- Valve seals FPM
- Working diaphragm EPDM
- Control cable 8-pole

C409.2-250e und C409.2-350e

- Pump body PP
- Single valve PP-FRP
- Valve balls glass
- Valve seals FPM
- Working diaphragm PTFE-faced
- Control cable 8-pole

Motor:



- 210-250V, 50/60Hz, 1~, IP55, ISO F

Further options and accessories

- Connection pieces see chapter 4
- Product documentation see chapter 5

Type	Basic design	x
C409.2-18e	16005272	
C409.2-25e	16005273	
C409.2-50e	16005274	
C409.2-75e	16005275	
C409.2-90e	16005276	
C409.2-115e	16005277	
C409.2-140e	16005278	
C409.2-180e	16005279	
C409.2-250e	16005288	
C409.2-350e	16005289	

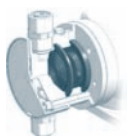
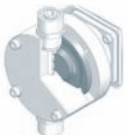
2

Options/Accessories		C409.2-18e	C409.2-50e	C409.2-90e	C409.2-115e	C409.2-250e
		C409.2-25e x	C409.2-75e x	C409.2-140e x	C409.2-180e x	C409.2-350e x
 Double diaphragm design with intermediate diaphragm made of:	CSM	-	▲	▲	▲	▲
	PTFE	▲	▲	▲	▲	⊙
	PTFE-faced	-	-	-	-	▲
 Working diaphragms	PTFE-faced	●	●	●	-	●
	EPDM	▲	▲	▲	●	-
	FPM	-	-	-	▲	-
 Diaphragm rupture monitoring Diaphragm rupture electrode conductive, mounted to pump	MBE-02 for single diaphragm pump	▲	▲	▲	▲	▲
	MBE-03 for double diaphragm pump	▲	▲	▲	▲	-
	MBE-04 for double diaphragm pump	-	-	-	-	▲
	Drive motor					
 Anschlussspannung 115V / 50/60 Hz	▲	▲	▲	▲	▲	

● = Basic design ⊙ = without add. price ▲ = with add. price ⊙ = on request - = not available Art.-Nr. = available in basic design/accessories

Order information

Basic design

C409.2-18e to C409.2-25e

- Pump body PP-FRP
- Double valves PP-FRP
- Valve balls glass
- Valve seals FPM
- Working diaphragm PTFE-faced
- Control cable 8-pole

C409.2-50e to C409.2-90e and C409.2-140e

- Pump body PP-FRP
- Double valves PP-FRP
- Valve balls glass
- Valve seals FPM
- Working diaphragm PTFE-faced
- Control cable 8-pole

C409.2-115e and C409.2-180e

- Pump body PP-FRP
- Single valve PP-FRP
- Valve balls glass
- Valve seals FPM
- Working diaphragm EPDM
- Control cable 8-pole

C409.2-250e und C409.2-350e

- Pump body PP
- Single valve PP-FRP
- Valve balls glass
- Valve seals FPM
- Working diaphragm PTFE-faced
- Control cable 8-pole





Motor:

- 210-250V, 50/60Hz, 1~, IP55, ISO F

Further options and accessories

- Connection pieces see chapter 4
- Product documentation see chapter 5

Type	Basic design	x
C409.2-18e	16005272	
C409.2-25e	16005273	
C409.2-50e	16005274	
C409.2-75e	16005275	
C409.2-90e	16005276	
C409.2-115e	16005277	
C409.2-140e	16005278	
C409.2-180e	16005279	
C409.2-250e	16005288	
C409.2-350e	16005289	

Options/Accessories		C409.2-18e	C409.2-50e	C409.2-90e	C409.2-115e	C409.2-250e
		C409.2-25e x	C409.2-75e x	C409.2-140e x	C409.2-180e x	C409.2-350e x
Control electronics 	Remote-design, for wall mounting incl. 3m cable	⊙	⊙	⊙	⊙	⊙
	Stroke length adjustment 	▲	▲	▲	▲	▲
Stroke length adjustment electrical 	Actuator N C1-BA 230 V, +/- 10%, 50/60 Hz, 128s/10 U, 1,5 Nm incl. mounting plate for actuator	▲	▲	▲	▲	▲
	Electronic positioning controller PMR3 input signal 0/4-20 mA incl. feedback signal 0/4-20 mA (only in N C1-BA integrated)	▲	▲	▲	▲	▲
Flow controller* 	IP65 incl. cable 0,6 m and cable box M12 5-pole (bushing for pump connection) Material valve seals: FPM Connection 8191.1/8192.1: Input: G 3/4 (Inlet), output: G 3/4 (outlet) Connection 8193.1: Input: G 1 (Inlet), output: 1 (outlet) Max. permissible operating pressure: 10 bar					
	8191.1 PP/FPM	37602175	–	–	–	–
	8191.1 PVC-U/FPM	37602227	–	–	–	–
	8192.1 PP/FPM	–	37602177	37602177	37602177	–
	8192.1 PVC-U/FPM	–	37602176	37602176	37602176	–
	8193.1 PP/FPM	–	–	–	–	37602240
8193.1 PVC-U/FPM	–	–	–	–	37602178	
*Note the indications in the data sheet						
● = Basic design ⊙ = without add. price ▲ = with add. price ⊕ = on request – = not available Art.-Nr. = available in basic design/accessories						

Order information

Basic design

C409.2-18e to C409.2-25e

- Pump body PP-FRP
- Double valves PP-FRP
- Valve balls glass
- Valve seals FPM
- Working diaphragm PTFE-faced
- Control cable 8-pole

C409.2-50e to C409.2-90e and C409.2-140e

- Pump body PP-FRP
- Double valves PP-FRP
- Valve balls glass
- Valve seals FPM
- Working diaphragm PTFE-faced
- Control cable 8-pole

C409.2-115e and C409.2-180e

- Pump body PP-FRP
- Single valve PP-FRP
- Valve balls glass
- Valve seals FPM
- Working diaphragm EPDM
- Control cable 8-pole

C409.2-250e und C409.2-350e

- Pump body PP
- Single valve PP-FRP
- Valve balls glass
- Valve seals FPM
- Working diaphragm PTFE-faced
- Control cable 8-pole

Motor:

- 210-250V, 50/60Hz, 1~, IP55, ISO F

Further options and accessories

- Connection pieces see chapter 4
- Product documentation see chapter 5

Type	Basic design	x
C409.2-18e	16005272	
C409.2-25e	16005273	
C409.2-50e	16005274	
C409.2-75e	16005275	
C409.2-90e	16005276	
C409.2-115e	16005277	
C409.2-140e	16005278	
C409.2-180e	16005279	
C409.2-250e	16005288	
C409.2-350e	16005289	

Options/Accessories

Flow meter*

IP65
incl. cable 0,6m and cable box M12 5-pole (bushing for pump connection)
Connection 8012.1 - 8014.1:
Inlet: G 3/4 (inside); Outlet G 3/4 (outside)
Connection 8015.1:
Inlet: G1 1/4 (inside); Outlet G1 1/4 (outside)
Max. operating pressure: 10 bar



		C409.2-18e C409.2-25e	x	C409.2-50e C409.2-75e	x	C409.2-90e C409.2-140e	x	C409.2-115e C409.2-180e	x	C409.2-250e C409.2-350e	x
8012.1	PVC-U/FPM	37602277		-		-		-		-	
	PVDF/FPM	37602307		-		-		-		-	
8013.1	PVC-U/FPM	-		37602279		-		-		-	
	PVC-U/FPM	-		37602279		-		-		-	
8014.1	PVC-U/FPM	-		-		37602281		37602281		-	
	PVDF/FPM	-		-		37602311		37602311		-	
8015.1	PVC-U/FPM	-		-		-		-		37602320	
	PVDF/FPM	-		-		-		-		37602332	
seals made of EPDM		○		○		○		○		○	

*Note the indications in the data sheet

Console

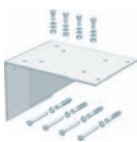

for wall mounting
incl. fixing screws

1.4301	90023875	90023875	90023875	90023875	90023875	90023875
PP	90023848	90023848	90023848	90023848	90023848	90023848

Special connection



Special connection (plug)
für power supply

⊗ ⊗ ⊗ ⊗ ⊗

Control cable



M12 cable box 3-pole, 5 meter für level input (Level monitor not included)

90022888 90022888 90022888 90022888 90022888

M12 cable box 3-pole, ready-made for level input (Level monitor not included)

90022877 90022877 90022877 90022877 90022877

● = Basic design ○ = without add. price ▲ = with add. price ⊗ = on request - = not available Art.-Nr. = available in basic design/accessories

Fittings for suction side of dosing pumps		C409.2-18e C409.2-25e		C409.2-50e		C409.2-75e C409.2-90e		C409.2-115e up to C409.2-180e		C409.2-250e C409.2-350e	
		Type	p.	Type	p.	Type	p.	Type	p.	Type	p.
Suction lance	with level switch 1-stage	SL-11.1	3.36	SL-02	3.34	SL-02	3.34	SL-02	3.34	S-04	3.40
		⊗		S-03	3.38	S-03	3.38	S-03	3.38	⊗	
	with level switch 2-stage	SL-12.1	3.36	SL-02	3.34	SL-02	3.34	SL-02	3.34	⊗	
		without level switch	S-01	3.42	S-01	3.42	S-01	3.42	S-01	3.42	S-01
Suction aid / Siphon Vessel	transparent PVC-U	770.2	3.74	770.2	3.74	770.2	3.74	770.2	3.74	770.2	3.74
Calibration Pot	PVC-U	792.1	3.76	792.1	3.76	793.1	3.76	794.1	3.76	795.1	3.76
Foot valve	PVC-U	731	3.78	731	3.78	731	3.78	731	3.78	732.2	3.80
	PP / PVDF	⊗		⊗		⊗		⊗		732	3.78
	PP-FRP / PVDF-FRP	781.1	3.82	781.1	3.82	781.1	3.82	781.1	3.82	783.1	3.82
	1.4571	731	3.78	731	3.78	731	3.78	731	3.78	732	3.78
Line strainer	PVC-U / PP / PVDF	752.1	3.84	752.1	3.84	752.1	3.84	752.1	3.84	752.1	3.84
	PVC-U	751.1	3.84	751.1	3.84	751.1	3.84	751.1	3.84	⊗	
	1.4408	752	3.86	752	3.86	752	3.86	752	3.86	752	3.86
Float valve	PVC-U	871	3.88	871	3.88	871	3.88	871	3.88	872	3.88
Pulsation damper without separating diaphragm	PVC-U / PP	702.1	3.14	702.1	3.14	702.1	3.14	702.1	3.14	702.1	3.14
	1.4571	802.1	3.18	802.1	3.18	802.1	3.18	802.1	3.18	802.1	3.18
Fittings for pressure side of dosing pumps		C409.2-18e C409.2-25e		C409.2-50e		C409.2-75e C409.2-90e		C409.2-115e up to C409.2-180e		C409.2-250e C409.2-350e	
		Type	p.	Type	p.	Type	p.	Type	p.	Type	p.
Diaphragm-type relief valve		620.10	3.4	620.10	3.4	622.10	3.4	622.10	3.4	622.10	3.4
	for suspension	⊗		⊗		622.S	3.6	622.S	3.6	622.S	3.6
Diaphragm-type pressure keeping valve		620.D	3.8	620.D	3.8	622.D	3.8	622.D	3.8	622.D	3.8
Multi-function valve	4 bar opening pressure	MFV 05004	3.10	MFV 05004	3.10	–		–		–	
	6 bar opening pressure	MFV 05006	3.10	MFV 05006	3.10	–		–		–	
	10 bar opening pressure	MFV 05010	3.10	MFV 05010	3.10	–		–		–	
Pulsation damper without separating diaphragm	PVC-U / PP	702.1	3.14	702.1	3.14	702.1	3.14	702.1	3.14	702.1	3.14
	1.4571	802.1	3.18	802.1	3.18	802.1	3.18	802.1	3.18	802.1	3.18
Diaphragm-pulsation damper with PTFE/PTFE-faced diaphragm	PVC-U / PP / PVDF	720.1	3.24	721.2	3.24	722.1	3.24	722.1	3.24	723.1	3.24
	1.4571	721.1	3.28	721.1	3.28	722.1	3.28	722.1	3.28	723.1	3.28
Diaphragm-pulsation damper with Elastomer-diaphragm	PVC-U / PP / PVDF	⊗		⊗		⊗		⊗		713.1	3.20
	1.4571	810.1-0,16/180	3.30	810.1-0,16/180	3.30	810.1-0,32/160	3.30	810.1-0,32/160	3.30	810.1-0,75/140	3.30
Check valve	PVC-U	661.2	3.48	661.2	3.48	661.2	3.48	661.2	3.48	⊗	
	PP-FRP / PVDF-FRP	661.2	3.48	661.2	3.48	661.2	3.48	661.2	3.48	663.2	3.48
	1.4571	661.2	3.48	661.2	3.48	661.2	3.48	661.2	3.48	662.2	3.48
Dosing valve	PVC-U	691.1	3.54	691.1	3.54	691.1	3.54	691.1	3.54	⊗	
	PVC-U / PP / PVDF	681.1	3.58	681.1	3.58	681.1	3.58	681.1	3.58	682.1	3.58
	PP-FRP / PVDF-FRP	691.1	3.54	691.1	3.54	691.1	3.54	691.1	3.54	693.1	3.54
	1.4571	691.1	3.54	691.1	3.54	691.1	3.54	691.1	3.54	692.1	3.54
Injection fitting	PVC-U / PP / PVDF	8061.1	3.60	8061.1	3.60	8061.1	3.60	8062.1	3.60	8062.1	3.60

⊗ = on request

– = not available

The above allocation considers the fittings which have to be used at least regarding their nominal width in order to ensure the safe and trouble-free operation of the respective pumps when feeding liquids which are resembling to water.

Absolutely note the max. admissible operating pressure of the fittings.

The use of fittings of a bigger nominal width is unproblematically possible in most cases.

When choosing the fittings note the installation instructions for dosing pumps or confer with s e r a .

CS409.2



CS409.2 in survey

- Self ventilating
- Compact design
- Low weight
- Safe if run dry
- Leakage free
- Low maintenance
- Easy to use
- High dosing accuracy
- Multifunctional
- Flexible
- Manual stroke length and stroke frequency adjustment
- Robust metallic housing

Infobox

- Order information [Page 2.31](#)
- Options/accessories [Page 2.31](#)
- fittings-allocation [Page 2.34](#)
- connecting pieces [Chapter 4](#)
- resistance chart [Chapter 5](#)
- installation examples [Chapter 5](#)

Functions and operating modes

- Manual operation
- Manual stroke frequency adjustment
- Profibus® DP - Interface*
- External START/STOP
- Pulse operation / fractinator
- Cycle delay unit
- Analogue operation (0/4-20 mA)
- Analogue operation standardization
- Charge manual/with timer
- Speed control / Slow mode
- 3 LED's for status indication
- Multiline illuminated text display
- Menu - driven parameterization
- Flow indication
- Calibration
- 4 - key operation
- 2 digital outputs (SPS)
- 1 digital input (SPS or contact signal)
- 2 analogue / digital inputs (optionally reversible)
- Programmable input-/output functions
- Connection / evaluation 2-stage level monitoring
- Connection / evaluation diaphragm rupture monitoring
- Connection / evaluation flow monitoring
- Connection / evaluation flow metering
- Automatic self-ventilating
- Voltage 210 - 250 V, 50/60 Hz
- 2m connecting cable Euro-plug

Technical data

Type	Nominal capacity		Nominal stroke frequency		Capacity per stroke ml/Hub	Admissible counter-pressure bar	Admissible pressure at pump inlet bar	Max. suction height mWS	Inlet nominal width	Outlet nominal width	Max. stroke length mm	Motor output kW
	50 Hz	60 Hz	50 Hz	60 Hz					DN	DN		
CS409.2-18e	0 - 18	0 - 21.5	100	120	3	10	-0.3 / 3	3	5	10	6	0.18
CS409.2-25e	0 - 25	0 - 30	150	180	3	10	-0.3 / 3	3	5	10	6	0.18

*e in type designation means: pump with single diaphragm

Dimensional drawing

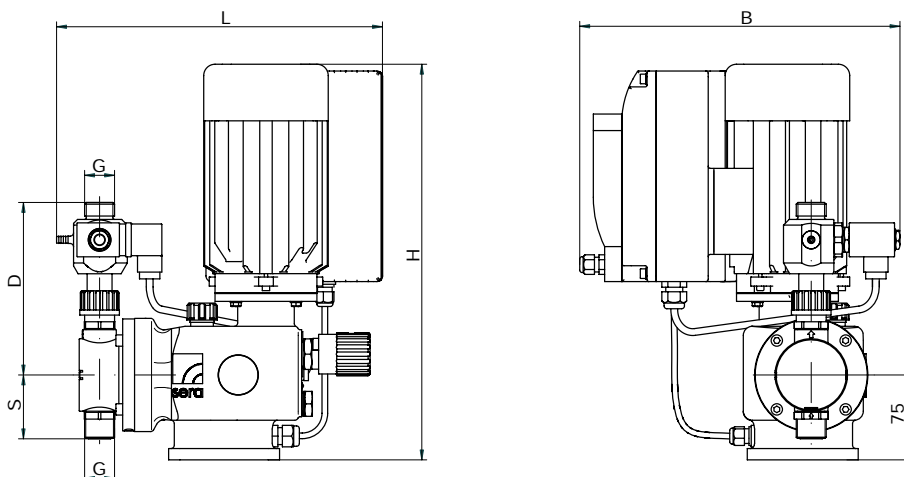

Dimensional chart

All indications in mm

Type	G	S	D	L	B	H	Weight kg
CS409.2-18e	G 3/4	56	64	270	250	380	11.1
CS409.2-25e	G 3/4	56	64	270	250	380	11.1

* available at the second half of 2007

Order information

Basic design

CS409.2-18e to CS409.2-25e

- Pump body PP-FRP
- Double valves PP-FRP
- Valve balls glass
- Valve seals FPM
- Working diaphragm PTFE-faced
- Control cable 8-pole
- Automatic vent valve PP





Motor:

- 210-250V, 50/60Hz, 1~, IP55, ISO F

Further options and accessories

- Connection pieces see chapter 4
- Product documentation see chapter 5

Type	Basic design	x
CS409.2-18e	16005290	
CS409.2-25e	16005291	

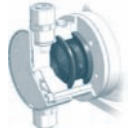
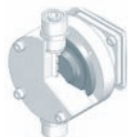
Options/Accessories			CS409.2-18e CS409.2-25e	x
Pump body and valves 	PP-FRP	double valves PP-FRP	●	
	PVC-U	single valves PVC-U	▲	
	PVDF-FRP	double valves PVDF-FRP	▲	
Valve balls 	Glass	single valves	○	
		double valves	●	
	1.4401	single valves	○	
		double valves	○	
	PTFE	single valves	▲	
		double valves	▲	
Valve sealings 	FPM	single valves	○	
		double valves	●	
	EPDM	single/double valves	○	
		FEP-covered	single/double valves	▲
Integrated relief valve 	with PTFE-faced diaphragm, connection seal FPM or EPDM at pump body made of:			
	PP		⊙	
	PVC-U		⊙	
	PVDF		⊙	
	Connection seals FEP-covered		⊙	
Double diaphragm design 	with intermediate diaphragm made of:			
	CSM		⊙	
	PTFE		⊙	
Working diaphragms 	PTFE-faced		●	
	EPDM		▲	
● = Basic design ▲ = with add. price ○ = without add. price ⊙ = on request Art.-Nr. = available in basic design/accessories				

Order information

Basic design

CS409.2-18e to CS409.2-25e

- Pump body PP-FRP
- Double valves PP-FRP
- Valve balls glass
- Valve seals FPM
- Working diaphragm PTFE-faced
- Control cable 8-pole
- Automatic vent valve PP

Further options and accessories





- Connection pieces see chapter 4
- Product documentation see chapter 5

Type	Basic design	x
CS409.2-18e	16005290	
CS409.2-25e	16005291	

Motor:

- 210-250V, 50/60Hz, 1~, IP55, ISO F

2

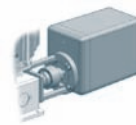
Options/Accessories		CS409.2-18e CS409.2-25e	x
Diaphragm rupture monitoring 	Diaphragm rupture electrode conductive, mounted to pump		
	MBE-02 for single diaphragm pump MBE-03 for double diaphragm pump	▲ ○	
Drive motor 	Anschlussspannung 115V / 50/60 Hz	▲	
Control electronics 	Remote-design, for wall mounting incl. 3m cable	○	
Stroke length adjustment 	with position indicator	▲	
Stroke length adjustment electrical 	Actuator N C1-BA 230 V, +/- 10%, 50/60 Hz, 128s/10 U, 1,5 Nm incl. mounting plate for actuator	○	
	Electronic positioning controller PMR3 input signal 0/4-20 mA incl. feedback signal 0/4-20 mA (only in N C1-BA integrated)	○	
● = Basic design ▲ = with add. price ○ = without add. price ○ = on request Art.-Nr. = available in basic design/accessories			

Order information

Basic design

CS409.2-18e to CS409.2-25e

- Pump body PP-FRP
- Double valves PP-FRP
- Valve balls glass
- Valve seals FPM
- Working diaphragm PTFE-faced
- Control cable 8-pole
- Automatic vent valve PP





Motor:

- 210-250V, 50/60Hz, 1~, IP55, ISO F

Further options and accessories

- Connection pieces see chapter 4
- Product documentation see chapter 5

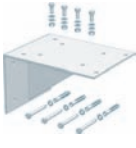
Type	Basic design	x
CS409.2-18e	16005290	
CS409.2-25e	16005291	

Options/Accessories		CS409.2-18e	CS409.2-25e	x								
Flow controller 	IP65 incl. cable 0,6 m and cable box M12 5-pole (bushing for pump connection) Material valve seals: FPM Connection: Input: G 3/4 (Inlet), output: G 3/4 (outlet) Max. permissible operating pressure: 10 bar											
	<table border="1"> <tr> <td>8191.1</td> <td>PP/FPM</td> <td>37602175</td> <td></td> </tr> <tr> <td></td> <td>PVC-U/FPM</td> <td>37602227</td> <td></td> </tr> </table>	8191.1	PP/FPM	37602175			PVC-U/FPM	37602227				
8191.1	PP/FPM	37602175										
	PVC-U/FPM	37602227										
Flow meter 	IP65 incl. cable 0,6m and cable box M12 5-pole (bushing for pump connection) Connection: Inlet G 3/4 (inside); Outlet G 3/4 (outside) Max. operating pressure: 10 bar											
	<table border="1"> <tr> <td>8012.1</td> <td>PVC-U/FPM</td> <td>37602277</td> <td></td> </tr> <tr> <td></td> <td>PVDF/FPM</td> <td>37602307</td> <td></td> </tr> </table>	8012.1	PVC-U/FPM	37602277			PVDF/FPM	37602307				
	8012.1	PVC-U/FPM	37602277									
	PVDF/FPM	37602307										
Sealings made of EPDM		○										
Console 	1.4301 for wall mounting incl. fixing screws		90023875									
	PP		90023848									
Special connection 	Special connection (plug) für power supply		⊗									
Control cable 	M12 cable box 3-pole, 5 meter für level input (Level monitor not included)		90022888									
	M12 cable box 3-pole, ready-made for level input (Level monitor not included)		900228877									
● = Basic design ▲ = with add. price ○ = without add. price ⊗ = on request Art.-Nr. = available in basic design/accessories												

Fittings for suction side of dosing pumps		CS409.2-18e CS409.2-25e		
		Type	p.	
Suction lance	with level switch 1-stage	SL-11.1	3.36	
	with level switch 2-stage	SL-12.1	3.36	
	without level switch	S-01	3.42	
Suction aid / Siphon Vessel	transparent PVC-U	770.2	3.74	
Calibration Pot	PVC-U	792.1	3.76	
	PVC-U	731	3.78	
Foot valve	PP-FRP / PVDF-FRP	781.1	3.82	
	1.4571	731	3.78	
	PVC-U	751.1	3.84	
Line strainer	PVC-U / PP / PVDF	752.1	3.84	
	1.4408	752	3.86	
	PVC-U	871	3.88	
Float valve	PVC-U	871	3.88	
Pulsation damper without separating diaphragm	PVC-U / PP	702.1	3.14	
	1.4571	802.1	3.18	
Fittings for pressure side of dosing pumps		CS409.2-18e CS409.2-25e		
		Type	p.	
Diaphragm-type relief valve		620.10	3.4	
Diaphragm-type pressure keeping valve		620.D	3.8	
Multi-function valve	4 bar opening pressure	MFV 05004	3.10	
	6 bar opening pressure	MFV 05006	3.10	
	10 bar opening pressure	MFV 05010	3.10	
Pulsation damper without separating diaphragm	PVC-U / PP	702.1	3.14	
	1.4571	802.1	3.18	
Diaphragm-pulsation damper with PTFE/PTFE-faced diaphragm		PVC-U / PP / PVDF	720.1	3.24
Diaphragm-pulsation damper with Elastomer-diaphragm		1.4571	810.1- 0,16/180	3.30
Check valve	PVC-U	661.2	3.48	
	PP-FRP / PVDF-FRP	661.2	3.48	
	1.4571	661.2	3.48	
Dosing valve	PVC-U	691.1	3.54	
	PVC-U / PP / PVDF	681.1	3.58	
	PP-FRP / PVDF-FRP	691.1	3.54	
	1.4571	691.1	3.54	
Injection fitting		PVC-U / PP / PVDF	8061.1	3.60

The above allocation considers the fittings which have to be used at least regarding their nominal width in order to ensure the safe and trouble-free operation of the respective pumps when feeding liquids which are resembling to water.

Absolutely note the max. admissible operating pressure of the fittings.

The use of fittings of a bigger nominal width is unproblematically possible in most cases.

When choosing the fittings note the installation instructions for dosing pumps or confer with s e r a.



C409.1-...KM in survey

- Compact design
- Safe if run dry
- Leakage free
- Low maintenance
- Easy to use
- High dosing accuracy
- Integrateable into automatic processes
- Digital and analog control possibilities
- Manual stroke length and stroke frequency adjustment
- Robust metallic stroke mechanism housing

Infobox

- Order information [Page 2.37](#)
- Options/accessories [Page 2.37](#)
- fittings-allocation [Page 2.39](#)
- connecting pieces [Chapter 4](#)
- resistance chart [Chapter 5](#)
- installation examples [Chapter 5](#)

Functions and operating modes

- Manual operation
- Manual stroke frequency adjustment
- Pulse operation / fractinator
- Analogue operation (0/4-20 mA)
- 4 LEDs for operating indicator, collective fault indicator, signal „empty“ indicator, diaphragm rupture indicator
- Mode selection switch
- Hand- / Automatic switch
- Collective fault
- Input 2-stage level monitoring
- Connection / evaluation diaphragm rupture monitoring
- Input evaluation flow monitoring
- Voltage 220 - 240 V, 50/60 Hz
- 2m connecting cable with Euro-plug

Technical data

Type	Nominal capacity		Nominal stroke frequency		Capacity per stroke ml/Hub	Admissible counter-pressure bar	Admissible pressure at pump inlet bar	Max. suction height mWS	Inlet/ Outlet nominal width DN	Max. stroke length mm	Motor output kW
	50 Hz	60 Hz	50 Hz	60 Hz							
C409.1-6,5KM/14	0 - 6.5	0 - 6.5	80	80	1.35	50	-0.2 / 0	2	8	10	0.25
C409.1-13KM/20	0 - 13	0 - 13	80	80	2.7	50	-0.2 / 0	2	8	10	0.25
C409.1-25KM/20	0 - 25	0 - 25	150	150	2.75	50	-0.2 / 0	2	8	10	0.25
C409.1-27KM/28	0 - 27	0 - 27	80	80	5.62	35	-0.2 / 0	2	8	10	0.25
C409.1-54KM/40	0 - 54	0 - 54	80	80	11.25	17	-0.2 / 0	2	8	10	0.25

Note: The admissible counterpressure is 10 bar when plastic pump bodies are used.

Dimensional drawing

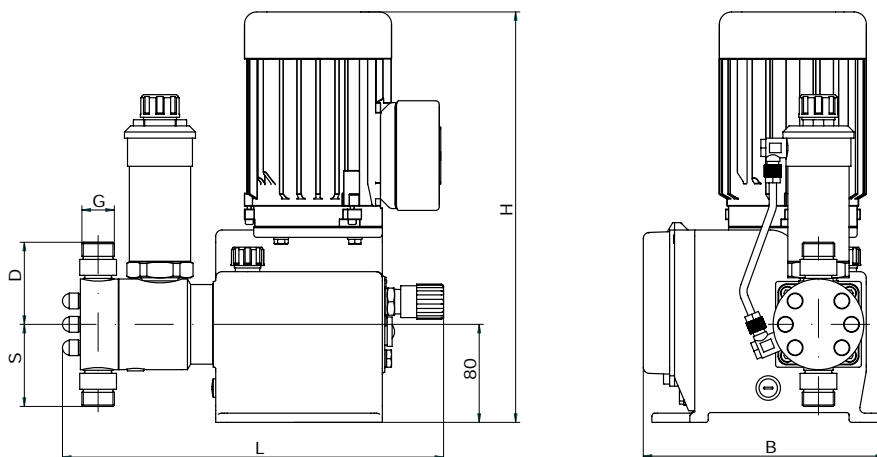

Dimensional chart

All indications in mm

Type	G	S	D	L	B	H	Weight kg
C409.1-6,5KM/14	G 3/4	62	62	309	205	360	22.5
C409.1-13KM/20	G 3/4	62	62	309	205	360	22.5
C409.1-25KM/20	G 3/4	62	62	309	205	360	22.5
C409.1-27KM/28	G 3/4	77	77	371	205	360	26
C409.1-54KM/40	G 3/4	77	77	371	205	360	26

Order information

Basic design

C409.1-...KM

- Pump body PP
- Double valve PP-FRP
- Valve balls glass
- Valve seals FPM
- Diaphragm PTFE-well



Motor:

- 220-240V AC-Motor, 50/60Hz, IP55, iso.cl.F

Further options and accessories:

- Connection pieces see chapter 4
- Product documentation see chapter 5

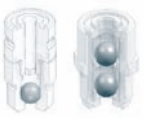
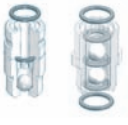
Type	Basic design	x
C409.1-6,5KM/14	16002329	
C409.1-13KM/20	16003872	
C409.1-25KM/20	16003843	
C409.1-27KM/28	16003823	
C409.1-54KM/40	16002981	

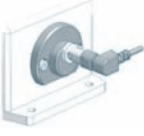
Options/Accessories			C409.1-6,5KM/14 up to C409.1-25KM/20	x	C409.1-27KM/28 C409.1-54KM/40	x
Pump body and valves 	PP	double valves PP-FRP	●		●	
	PVC-U	chamber valves (double valves) PVC-U	▲		–	
		single valves PVC-U	–		▲	
	PVDF	double valves PVDF-FRP	▲		▲	
		chamber valves (double valves) 1.4571	▲		–	
1.4571	double valves 1.4571/1.4581	–		▲		
Valve balls 	Glass	single valves	–		○	
		double valves	●		●	
	1.4401	single valves	–		○	
		double valves	○		○	
	PTFE	single valves	–		▲	
		double valves	▲		▲	
Valve sealings 	FPM	single valves	○		○	
		double valves	●		●	
	EPDM	single valves	○		○	
		double valves	–		○	
	FEP-covered	single valves	–		▲	
		double valves	▲		▲	
Piston-double diaphragm design 	Diaphragm ring (1.4571) incl. diaphragm made of waded PTFE		▲		▲	
	Diaphragm rupture monitoring 		Diaphragm rupture electrode conductive, mounted to pump			
	MBE-04		▲		▲	
Stroke frequency monitoring 	Inductive contact					
		10-60 V DC, three-wire, PNP		▲		▲
● = Basic design ▲ = with add. price ○ = without add. price ⊗ = on request – = not available Art.-Nr. = available in basic design/accessories						

Order information

Basic design

C409.1-...KM

- Pump body PP
- Double valve PP-FRP
- Valve balls glass
- Valve seals FPM
- Diaphragm PTFE-well

Motor:



- 220-240V AC-Motor, 50/60Hz, IP55, iso. cl.F

Further options and accessories:

- Connection pieces see chapter 4
- Product documentation see chapter 5

Type	Basic design	x
C409.1-6,5KM/14	16002329	
C409.1-13KM/20	16003872	
C409.1-25KM/20	16003843	
C409.1-27KM/28	16003823	
C409.1-54KM/40	16002981	

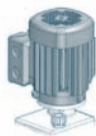
2

Options/Accessories		C409.1-6,5KM/14 up to C409.1-25KM/20	x	C409.1-27KM/28 C409.1-54KM/40	x	
Drive motor 	Special voltage 110 V, 0.25 kW	▲		▲		
	Stroke length adjustment electrical 	Actuator N C1-BA 230 V, +/- 10%, 50/60 Hz, 128s/10 U, 1,5 Nm incl. mounting plate for actuator	▲		▲	
Flow controller 	Electronic positioning controller PMR3 input signal 0/4-20 mA incl. feedback signal 0/4-20 mA (only in N C1-BA integrated)	▲		▲		
	IP65 incl. cable 0,6 m and cable box M12 5-pole (bushing for pump connection) Material valve seals: FPM Connection: Input: G 3/4 (Inlet), output: G 3/4 (outlet) Max. permissible operating pressure: 10 bar					
	8191	PVC-U/FPM	30098001		30098001	
		PP/FPM	30098006		30098006	
		PVDF/FPM	30098011		30098011	
	8192*	PVC-U/FPM	30098002		30098002	
		PP/FPM	30098007		30098007	
		PVDF/FPM	30098012		30098012	
	8193*	PVC-U	⓪		⓪	
		PP/FPM	⓪		⓪	
	PVDF/FPM	⓪		⓪		
	PVC-U/FPM	⓪		⓪		
* Compare the application of the flow controller with the stroke volume of the pump which is to be set, use a smaller type, if necessary (note the indications in the data sheet)						
● = Basic design ▲ = with add. price ○ = without add. price ⓪ = on request – = not available Art.-Nr. = available in basic design/accessories						

Fittings for suction side of dosing pumps		C409.1-6,5KM/14 C409.1-13KM/20		C409.1-25KM/20		C409.1-27KM/28		C409.1-54KM/40	
		Type	p.	Type	p.	Type	p.	Type	p.
Suction lance	with level switch 1-stage	SL-11.1	3.36	SL-02	3.34	SL-02	3.34	SL-02	3.34
		S-03	3.38	S-03	3.38	S-03	3.38	S-03	3.38
	with level switch 2-stage without level switch	SL-12.1	3.36	SL-02	3.34	SL-02	3.34	SL-02	3.34
		S-01	3.42	S-01	3.42	S-01	3.42	S-01	3.42
Suction aid / Siphon Vessel	transparent PVC-U	770.2	3.74	770.2	3.74	770.2	3.74	770.2	3.74
Calibration Pot	PVC-U	791.1	3.76	792.1	3.76	792.1	3.76	792.1	3.76
	PVC-U	731	3.78	731	3.78	731	3.78	731	3.78
Foot valve	PP-FRP / PVDF-FRP	781.1	3.82	781.1	3.82	781.1	3.82	781.1	3.82
	1.4571	731	3.78	731	3.78	731	3.78	731	3.78
	PVC-U	751.1	3.84	751.1	3.84	751.1	3.84	751.1	3.84
Line strainer	1.4408	752	3.86	752	3.86	752	3.86	752	3.86
	PVC-U	871	3.88	871	3.88	871	3.88	871	3.88
Float valve	PVC-U	871	3.88	871	3.88	871	3.88	871	3.88
Pulsation damper without separating diaphragm	PVC-U / PP	702.1	3.14	702.1	3.14	702.1	3.14	702.1	3.14
	1.4571	802.1	3.18	802.1	3.18	802.1	3.18	802.1	3.18
Fittings for pressure side of dosing pumps		C409.1-6,5KM/14 C409.1-13KM/20		C409.1-25KM/20		C409.1-27KM/28		C409.1-54KM/40	
		Type	p.	Type	p.	Type	p.	Type	p.
Diaphragm-type relief valve	for suspension	620.10	3.4	620.10	3.4	620.10	3.4	620.10	3.4
		⊗		⊗		⊗		⊗	
Diaphragm-type pressure keeping valve		620.D	3.8	620.D	3.8	620.D	3.8	620.D	3.8
Multi-function valve	4 bar opening pressure	MFV 05004	3.10	MFV 05004	3.10	MFV 05004	3.10	MFV 05004	3.10
	6 bar opening pressure	MFV 05006	3.10	MFV 05006	3.10	MFV 05006	3.10	MFV 05006	3.10
	10 bar opening pressure	MFV 05010	3.10	MFV 05010	3.10	MFV 05010	3.10	MFV 05010	3.10
Pulsation damper without separating diaphragm	PVC-U / PP	702.1	3.14	702.1	3.14	702.1	3.14	702.1	3.14
	1.4571	802.1	3.18	802.1	3.18	802.1	3.18	802.1	3.18
Diaphragm-pulsation damper with PTFE/PTFE-faced diaphragm	PVC-U / PP / PVDF	720.1	3.24	720.1	3.24	720.1	3.24	721.2	3.24
	1.4571	721.1	3.28	721.1	3.28	721.1	3.28	721.1	3.28
Diaphragm-pulsation damper with Elastomer-diaphragm	1.4571	810.1-0,16/180	3.30	810.1-0,16/180	3.30	810.1-0,16/180	3.30	810.1-0,16/180	3.30
Check valve	PVC-U	661.2	3.48	661.2	3.48	661.2	3.48	661.2	3.48
	PP-FRP / PVDF-FRP	661.2	3.48	661.2	3.48	661.2	3.48	661.2	3.48
	1.4571	661.2	3.48	661.2	3.48	661.2	3.48	661.2	3.48
Dosing valve	PVC-U	691.1	3.54	691.1	3.54	691.1	3.54	691.1	3.54
	PVC-U / PP / PVDF	681.1	3.58	681.1	3.58	681.1	3.58	681.1	3.58
	PP-FRP / PVDF-FRP	691.1	3.54	691.1	3.54	691.1	3.54	691.1	3.54
	1.4571	691.1	3.54	691.1	3.54	691.1	3.54	691.1	3.54
Injection fitting	PVC-U / PP / PVDF	8061.1	3.60	8061.1	3.60	8061.1	3.60	8061.1	3.60

⊗ = on request

The above allocation considers the fittings which have to be used at least regarding their nominal width in order to ensure the safe and trouble-free operation of the respective pumps when feeding liquids which are resembling to water.

Absolutely note the max. admissible operating pressure of the fittings.

The use of fittings of a bigger nominal width is unproblematically possible in most cases.

When choosing the fittings note the installation instructions for dosing pumps or confer with s e r a.

Diaphragm pumps

Flow capacity 1,2 l/h ... 25 l/h

Admissible counterpressure up to 10 bar



R302



R302 in survey

- Compact underfloor design
- Little weight
- Leakage-free
- High dosing accuracy
- Safe if run dry
- High quality materials
- No-maintenance
- Robust corrosion-resistant stroke mechanism housing

Infobox

- Order information [Page 2.41](#)
- Options/accessories [Page 2.41](#)
- fittings-allocation [Page 2.43](#)
- connecting pieces [Chapter 4](#)
- resistance chart [Chapter 5](#)
- installation examples [Chapter 5](#)

Technical data

Type	Nominal capacity		Nominal stroke frequency		Admissible counterpressure bar	Admissible pressure at pump inlet bar	max. suction height mWS	Inlet/ Outlet nominal width DN	Max. stroke length mm	Motor output kW
	l/h		1/min							
R302-1,2e	0 - 1.2	0 - 1.4	150	180	10	-0.3 / 0	3	5	1.5	0.06
R302-2,4e	0 - 2.4	0 - 2.8	150	180	10	-0.3 / 0	3	5	1.5	0.06
R302-6,0e	0 - 6	0 - 7.2	150	180	10	-0.3 / 0	3	5	1.5	0.06
R302-13e	0 - 13	0 - 15.6	150	180	6	-0.3 / 0	3	5	1.5	0.06
R302-25e	0 - 25	0 - 30	150	180	4	-0.3 / 0	3	10	1.5	0.06

e in type designation means: pump with single diaphragm

Dimensional drawing

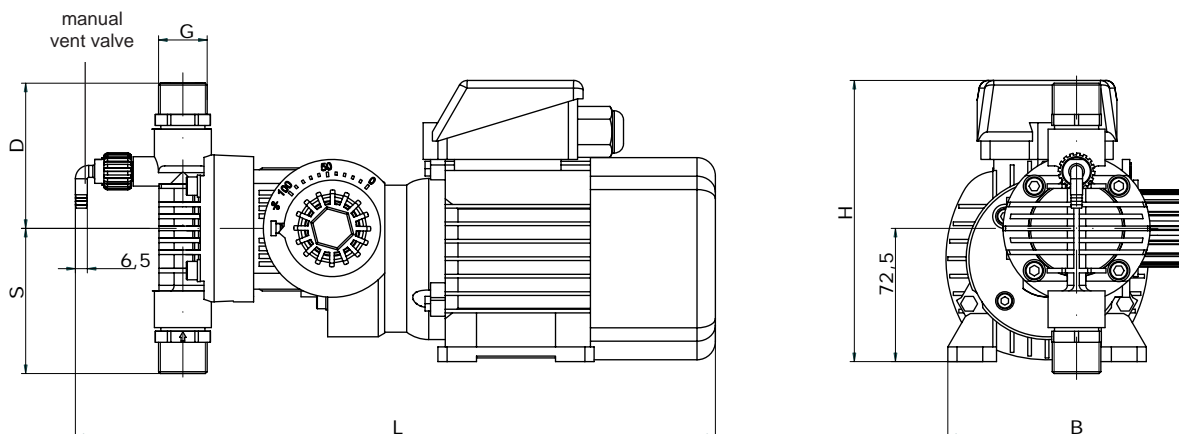

Dimensional chart

All indications in mm

Type	G	S	D	L	B	H	Weight kg
R302-1,2e	G 3/4	79	79	350	133	153	5
R302-2,4e	G 3/4	79	79	350	133	153	5
R302-6,0e	G 3/4	79	79	350	133	153	5
R302-13e	G 3/4	79	79	350	133	153	5
R302-25e	G 3/4	75	75	310	133	153	5

Manual vent valve only with PP-FRP und PVDF-FRP design at pumps with a nominal capacity up to 13 l/h

Order information

Basic design

R302-1,2e up to R302-13e:

- Pump body PP-FRP
- Double valves PP-FRP
- Valve balls glass
- Valve seals FPM
- Working diaphragm PTFE-faced
- Manual vent valve PP-FRP with hose nozzle (only with pump body made of PP-FRP/PVDF-FRP)

R302-25e:

- Pump body PP-FRP
- Double valves PP-FRP
- Valve balls glass
- Valve seals FPM
- Working diaphragm PTFE-faced





Motor:

- 220-240/380-420V threephase, 50/60 Hz, IP 55, insul. cl. F

Further options and accessories:

- Connection pieces see chapter 4
- Product documentation see chapter 5

Type	Basic design	x
R302-1,2e	16000284	
R302-2,4e	16001284	
R302-6,0e	16000711	
R302-13e	16000754	
R302-25e	16000941	

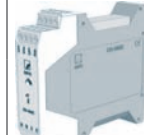
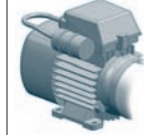
Options/Accessories			R302-1,2e up to R302-13e	x	R302-25e	x
	PP-FRP	double valves PP-FRP	●		●	
	PVC-U	single valves PVC-U	-		▲	
		chamber valves (double valves) PVC-U	▲		-	
	PVDF-FRP	double valves PVDF-FRP	▲		⊗	
PVDF	double valves PVDF-FRP	-		⊗		
	Glass	single valves	-		○	
		double valves	●		●	
	1.4401	single valves	-		○	
		double valves	○		○	
	PTFE	single valves	-		▲	
		double valves	▲		▲	
	FPM	single valves	-		●	
		double valves	●		●	
	EPDM	single valves	-		○	
		double valves	○		○	
	FEP-covered	single valves	-		▲	
		double valves	▲		▲	
	MBE-02	for single diaphragm pump	▲		▲	
		Electrode relay, control cabinet assembly				
	ER-104/C	aux. energy 230 V AC	90022994		90022994	
		aux. energy 24 V DC	90022945		90022945	
	Single phase AC 230 V +/- 10%, 0,09 kW, 50/60 Hz, IP55, ISO F		▲		▲	
● = Basic design ▲ = with add. price ○ = without add. price ⊗ = on request - = not available Art.-Nr. = available in basic design/ accessories						

Order information

Basic design

R302-1,2e up to R302-13e:

- Pump body PP-FRP
- Double valves PP-FRP
- Valve balls glass
- Valve seals FPM
- Working diaphragm PTFE-faced
- Manual vent valve PP-FRP with hose nozzle (only with pump body made of PP-FRP/PVDF-FRP)

R302-25e:

- Pump body PP-FRP
- Double valves PP-FRP
- Valve balls glass
- Valve seals FPM
- Working diaphragm PTFE-faced

Motor:

- 220-240/380-420V threephase, 50/60 Hz, IP 55, insul. cl. F

Further options and accesories:

- Connection pieces see chapter 4
- Product documentation see chapter 5

Type	Basic design	x
R302-1,2e	16000284	
R302-2,4e	16001284	
R302-6,0e	16000711	
R302-13e	16000754	
R302-25e	16000941	

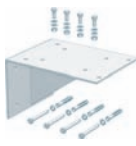
Options/Accessories		R302-1,2e up to R302-13e	x	R302-25e	x
 <p>Console</p> <p>for wall mounting incl. fixing screws</p>	1.4301	90023872		90023872	
	PP	90023844		90023844	
<p>● = Basic design ▲ = with add. price ○ = without add. price ⊗ = on request – = not available Art.-Nr. = available in basic design/ accessories</p>					

Fittings for suction side of dosing pumps		R302-1,2e up to R302-6,0e		R302-13e		R302-25e		
		Type	p.	Type	p.	Type	p.	
Suction lance	with level switch 1-stage	SL-11.1	3.36	SL-11.1	3.36	SL-11.1	3.36	
	with level switch 2-stage	SL-12.1	3.36	SL-12.1	3.36	SL-12.1	3.36	
	without level switch	S-01	3.42	S-01	3.42	S-01	3.42	
Priming aid	transparent PVC-U	769.1	3.72	769.1	3.72	769.1	3.72	
Suction aid / Siphon Vessel	transparent PVC-U	770.2	3.74	770.2	3.74	770.2	3.74	
Calibration Pot	PVC-U	791.1	3.76	792.1	3.76	792.1	3.76	
Foot valve	PVC-U	731	3.78	731	3.78	731	3.78	
	PP-FRP / PVDF-FRP	781.1	3.82	781.1	3.82	781.1	3.82	
	1.4571	731	3.78	731	3.78	731	3.78	
Line strainer	PVC-U	751.1	3.84	751.1	3.84	751.1	3.84	
	PVC-U / PP / PVDF	752.1	3.84	752.1	3.84	752.1	3.84	
Float valve	PVC-U	871	3.88	871	3.88	871	3.88	
Pulsation damper without separating diaphragm	PVC-U / PP	702.1	3.14	702.1	3.14	702.1	3.14	
	1.4571	802.1	3.18	802.1	3.18	802.1	3.18	
Fittings for pressure side of dosing pumps		R302-1,2e up to R302-6,0e		R302-13e		R302-25e		
		Type	p.	Type	p.	Type	p.	
Diaphragm-type relief valve		620.10	3.4	620.10	3.4	620.10	3.4	
Diaphragm-type pressure keeping valve		620.D	3.8	620.D	3.8	620.D	3.8	
Multi-function valve	4 bar opening pressure	MFV 05004	3.10	MFV 05004	3.10	MFV 05004	3.10	
	6 bar opening pressure	MFV 05006	3.10	MFV 05006	3.10	–	–	
	10 bar opening pressure	MFV 05010	3.10	–	–	–	–	
Pulsation damper without separating diaphragm	PVC-U / PP	702.1	3.14	702.1	3.14	702.1	3.14	
	1.4571	802.1	3.18	802.1	3.18	802.1	3.18	
Diaphragm-pulsation damper with PTFE/PTFE-faced diaphragm		PVC-U / PP / PVDF	720.1	3.24	720.1	3.24	720.1	3.24
Diaphragm-pulsation damper with Elastomer-diaphragm		1.4571	810.1- 0,16/180	3.30	810.1- 0,16/180	3.30	810.1- 0,16/180	3.30
Check valve	PVC-U	661.2	3.48	661.2	3.48	661.2	3.48	
	PP-FRP / PVDF-FRP	661.2	3.48	661.2	3.48	661.2	3.48	
	1.4571	661.2	3.48	661.2	3.48	661.2	3.48	
Dosing valve	PVC-U	691.1	3.54	691.1	3.54	691.1	3.54	
	PVC-U / PP / PVDF	681.1	3.58	681.1	3.58	681.1	3.58	
	PP-FRP / PVDF-FRP	691.1	3.54	691.1	3.54	691.1	3.54	
	1.4571	691.1	3.54	691.1	3.54	691.1	3.54	
Injection fitting		PVC-U / PP / PVDF	8061.1	3.60	8061.1	3.60	8061.1	3.60







– = not available

The above allocation considers the fittings which have to be used at least regarding their nominal width in order to ensure the safe and trouble-free operation of the respective pumps when feeding liquids which are resembling to water.

Absolutely note the max. admissible operating pressure of the fittings.

The use of fittings of a bigger nominal width is unproblematically possible in most cases.

When choosing the fittings note the installation instructions for dosing pumps or confer with s e r a.

Dosing- and feeding pumps for heavy industrial operating conditions, Ex-zone	Series	Flow capacity	Counter pressure	Page
	Diaphragm pumps R 409.2 R 410.2 M/R 414 M/R 415	18 l/h ▼ 4000 l/h	10 bar ▲ 3 bar	2.46
	Diaphragm-multi-headed-pumps ZR 408.1 ZR 409.1 DR 409.1	2 x 3,75 l/h ▼ 3 x 190 l/h	10 bar ▲ 4 bar	2.72
	Diaphragm-feeding pumps ZYM 409.1 ZX... 411.3	450 l/h ▼ 3100 l/h	4 bar ▲ 2 bar	2.90
	Piston diaphragm pumps R 409.1-KM R 411.1-KM R 413-KM	8,5 l/h ▼ 1500 l/h	50 bar ▲ 8 bar	2.102
	Piston pumps R 409.1-K.1 R 408.1-P	0,4 l/h ▼ 52 l/h	140 bar ▲ 20 bar	2.120
	Multi-layer diaphragm pumps R 409.1-ML R 411.1-ML	9,0 l/h ▼ 600 l/h	20 bar ▲ 4 bar	2.130
	Air-driven Diaphragm pumps APB - ... APE - ...	5,0 l/min. ▼ 850 l/min.	7,0 bar ▲ 0,5 bar	2.142



R 409.2 in survey

- Compact design
- Little weight
- Safe to run dry
- Leakage-free
- Low maintenance
- User-friendly
- High dosing accuracy
- Integratable into automatic processes
- Manual stroke length adjustment
- Robust metallic stroke mechanism housing

Infobox

- Order information [Page 2.47](#)
- Options/accessories [Page 2.47](#)
- fittings-allocation [Page 2.52](#)
- connecting pieces [Chapter 4](#)
- resistance chart [Chapter 5](#)
- installation examples [Chapter 5](#)

Technical data

Type	Nominal capacity		Nominal stroke frequency		Capacity per stroke ml/Hub	Admissible counterpressure bar	Admissible pressure at pump inlet bar	Max. suction height mWS	Inlet/Outlet nominal width DN	Max. stroke length mm	Motor output kW
	l/h		1/min								
	50 Hz	60 Hz	50 Hz	60 Hz							
R409.2-18e	0 - 18	0 - 21.5	100	120	3	10	-0.3 / 0	3	10	6	0.18
R409.2-25e	0 - 25	0 - 30	150	180	3	10	-0.3 / 0	3	10	6	0.18
R409.2-50e	0 - 50	0 - 60	100	120	8.3	10	-0.3 / 0	3	10	8	0.18
R409.2-75e	0 - 75	0 - 90	150	180	8.3	10	-0.3 / 0	3	15	8	0.18
R409.2-90e	0 - 90	0 - 108	100	120	15	8	-0.3 / 0	3	15	10	0.37
R409.2-115e	0 - 115	0 - 138	100	120	19.8	4	-0.3 / 0	3	15	10	0.18
R409.2-140e	0 - 140	0 - 168	150	180	15	8	-0.3 / 0	3	15	10	0.37
R409.2-180e	0 - 180	0 - 216	150	180	19.8	4	-0.3 / 0	3	15	10	0.18
R409.2-250e	0 - 250	0 - 300	100	120	38.8	3	-0.3 / 0	3	15	10	0.37
R409.2-350e	0 - 350	–	150	–	38.8	3	-0.3 / 0	3	15	10	0.37

e in type designation means: pump with single diaphragm / Smaller capacities of series R409.2 on request

Dimensional drawing

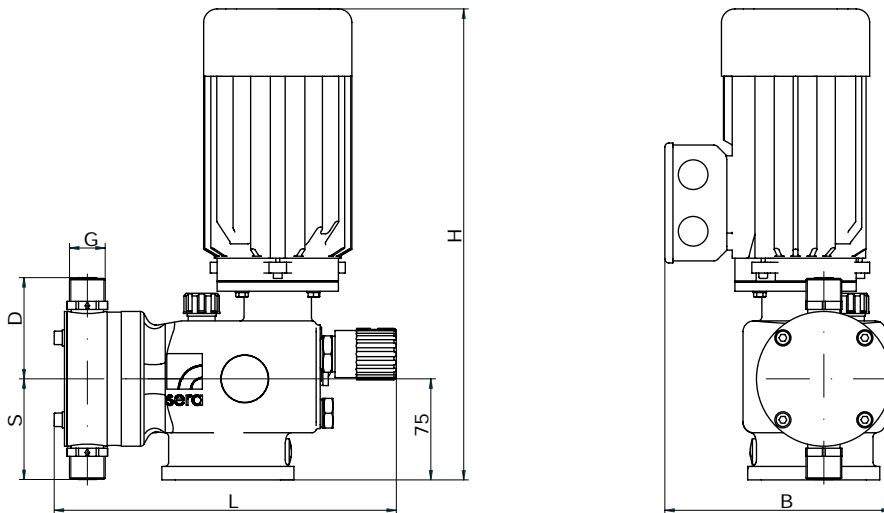

Dimensional chart

All indications in mm

Type	G	S	D	L	B	H	Weight kg
R409.2-18e	G 3/4	56	64	270	190	380	8.6
R409.2-25e	G 3/4	56	64	270	190	380	8.6
R409.2-50e	G 3/4	69	69	270	190	380	8.4
R409.2-75e	G 3/4	69	69	270	190	380	8.4
R409.2-90e	G 3/4	76	76	275	192	380	10.5
R409.2-115e	G 3/4	76	76	275	192	380	9
R409.2-140e	G 3/4	76	76	275	192	380	10.5
R409.2-180e	G 3/4	76	76	275	192	380	9
R409.2-250e	G 1 1/4	122	122	330	225	380	13
R409.2-350e	G 1 1/4	122	122	330	225	380	13

Indication of weight for Basic design acc. to order information

Order information

Basic design

R409.2-18e to R409.2-25

- Pump body PP-FRP
- Double valves PP-FRP
- Valve balls glass
- Valve seals FPM
- Working diaphragm PTFE-faced

R409.2-50e to R409.2-90e and R409.2-140

- Pump body PP-FRP
- Single valves PP-FRP
- Valve balls glass
- Valve seals FPM
- Working diaphragm PTFE-faced

R409.2-115e and R409.2-180e

- Pump body PP-FRP
- Single valve PP-FRP
- Valve balls glass
- Valve seals FPM
- Working diaphragm EPDM

R409.2-250e and R409.2-350e

- Pump body PP
- Single valve PP-FRP
- Valve balls glass
- Valve seals FPM
- Working diaphragm PTFE-faced





Motor:

- 220-240/380-420 V +/- 5% threephase, 50/60 Hz, IP 55, insul. cl. F

Further options and accessories

- Connection pieces see chapter 4
- Product documentation see chapter 5

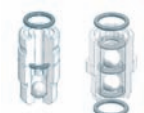
Type	Basic design	x
R409.2-18e	16005264	
R409.2-25e	16005265	
R409.2-50e	16005266	
R409.2-75e	16005267	
R409.2-90e	16005268	
R409.2-115e	16005269	
R409.2-140e	16005270	
R409.2-180e	16005271	
R409.2-250e	16005280	
R409.2-350e	16005281	

Options/Accessories			R409.2-18e	R409.2-50e	R409.2-90e	R409.2-115e	R409.2-250e
			R409.2-25e x	R409.2-75e x	R409.2-140e x	R409.2-180e x	R409.2-350e x
Pump body and valves 	PP-FRP	single valves PP-FRP	–	●	●	●	–
		double valves PP-FRP	●	○	○	○	–
	PP	single valves PP-FRP	–	–	–	–	●
		single valves PVC-U	▲	▲	▲	▲	▲
	PVDF-FRP	single valves PVDF-FRP	–	▲	▲	▲	–
		double valves PVDF-FRP	▲	▲	▲	▲	–
	PVDF	single valves PVDF-FRP	–	–	–	–	▲
		double valves PVDF-FRP	–	–	–	–	▲
1.4571	single valves 1.4571/1.4581	–	–	–	–	▲	
	double valves 1.4571/1.4581	▲	▲	▲	▲	▲	
Valve balls 	Glass	single valves	○	●	●	●	●
		double valves	●	○	○	○	○
	1.4401	single valves	○	○	○	○	▲
		double valves	○	○	○	○	●
PTFE	single valves	▲	▲	▲	▲	▲	
	double valves	▲	▲	▲	▲	●	
Valve sealings 	FPM	single valves	○	●	●	●	●
		double valves	●	○	○	○	○
	EPDM	single/double valves	○	○	○	○	●
		FEP-covered	single/double valves	●	●	●	●
Intergrated relief valve 	with PTFE-faced diaphragm, connection seal FPM or EPDM at pump body made of:						
	PP		▲	▲	▲	▲	▲
	PVC-U		▲	▲	▲	▲	▲
	PVDF		⊗	⊗	⊗	⊗	⊗
	1.4571		▲	▲	▲	▲	▲
	Connection seals FEP-covered		▲	▲	▲	▲	▲

● = Basic design ▲ = with add. price ○ = without add. price ⊗ = on request – = not available Art.-Nr. = available in basic design/accessories

Order information

Basic design

R409.2-18e to R409.2-25

- Pump body PP-FRP
- Double valves PP-FRP
- Valve balls glass
- Valve seals FPM
- Working diaphragm PTFE-faced

R409.2-50e to R409.2-90e and R409.2-140e

- Pump body PP-FRP
- Single valves PP-FRP
- Valve balls glass
- Valve seals FPM
- Working diaphragm PTFE-faced

R409.2-115e and R409.2-180e

- Pump body PP-FRP
- Single valve PP-FRP
- Valve balls glass
- Valve seals FPM
- Working diaphragm EPDM

R409.2-250e and R409.2-350e

- Pump body PP
- Single valve PP-FRP
- Valve balls glass
- Valve seals FPM
- Working diaphragm PTFE-faced

Motor:



- 220-240/380-420 V +/- 5% threephase, 50/60 Hz, IP 55, insul. cl. F

Further options and accessories

- Connection pieces see chapter 4
- Product documentation see chapter 5

Type	Basic design	x
R409.2-18e	16005264	
R409.2-25e	16005265	
R409.2-50e	16005266	
R409.2-75e	16005267	
R409.2-90e	16005268	
R409.2-115e	16005269	
R409.2-140e	16005270	
R409.2-180e	16005271	
R409.2-250e	16005280	
R409.2-350e	16005281	

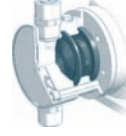
Options/Accessories

		R409.2-18e	R409.2-50e	R409.2-90e	R409.2-115e	R409.2-250e	
		R409.2-25e	R409.2-75e	R409.2-140e	R409.2-180e	R409.2-350e	
		x	x	x	x	x	
 Double diaphragm design	with intermediate diaphragm made of:						
	CSM	▲	▲	▲	▲	▲	
	PTFE	▲	▲	▲	▲	⊙	
	PTFE-faced	-	-	-	-	▲	
 Working diaphragms	PTFE-faced	●	●	●	-	●	
	EPDM	▲	▲	▲	●	-	
	FPM	-	-	-	▲	-	
 Diaphragm rupture monitoring	Diaphragm rupture electrode conductive, mounted to pump						
	MBE-02 for single diaphragm pump	▲	▲	▲	▲	▲	
	MBE-03 for double diaphragm pump	▲	▲	▲	▲	-	
	MBE-04 for double diaphragm pump	-	-	-	-	▲	
 Diaphragm rupture monitoring	ATEX-Design (Type examination, only for Double diaphragm design) Diaphragm rupture monitoring, konduktiv, mounted on the pump						
	MBE-03 incl. Connection cable for Diaphragm rupture monitoring blue for EExia-circuit (5m)	▲	▲	▲	▲	▲	
	MBE-04 incl. Connection cable for Diaphragm rupture monitoring blue for EExia-circuit (5m)	▲	▲	▲	▲	-	
	Buffer fluid glycol-glycerine-mixture 1:25 for media with conductivity <= 5µS/cm	-	-	-	-	▲	
		● = Basic design	▲ = with add. price	○ = without add. price	⊙ = on request	- = not available	Art.-Nr. = available in basic design/accessories

Order information

Basic design

R409.2-18e to R409.2-25

- Pump body PP-FRP
- Double valves PP-FRP
- Valve balls glass
- Valve seals FPM
- Working diaphragm PTFE-faced

R409.2-50e to R409.2-90e and R409.2-140

- Pump body PP-FRP
- Single valves PP-FRP
- Valve balls glass
- Valve seals FPM
- Working diaphragm PTFE-faced

R409.2-115e and R409.2-180e

- Pump body PP-FRP
- Single valve PP-FRP
- Valve balls glass
- Valve seals FPM
- Working diaphragm EPDM

R409.2-250e and R409.2-350e

- Pump body PP
- Single valve PP-FRP
- Valve balls glass
- Valve seals FPM
- Working diaphragm PTFE-faced





Motor:

- 220-240/380-420 V +/- 5% threephase, 50/60 Hz, IP 55, insul. cl. F

Further options and accessories

- Connection pieces see chapter 4
- Product documentation see chapter 5

Type	Basic design	x
R409.2-18e	16005264	
R409.2-25e	16005265	
R409.2-50e	16005266	
R409.2-75e	16005267	
R409.2-90e	16005268	
R409.2-115e	16005269	
R409.2-140e	16005270	
R409.2-180e	16005271	
R409.2-250e	16005280	
R409.2-350e	16005281	

Options/Accessories		R409.2-18e	R409.2-50e	R409.2-90e	R409.2-115e	R409.2-250e
		R409.2-25e x	R409.2-75e x	R409.2-140e x	R409.2-180e x	R409.2-350e x
Diaphragm rupture monitoring 	Electrode relay, control cabinet assembly					
	ER-104/C	aux. energy 230 V AC	90022994	90022994	90022994	90022994
		aux. energy 24 V DC	90022945	90022945	90022945	90022945
	ER-142	aux. energy 230 V AC II(1)G [EEExia] IIC acc. to ATEX 95	90200363	90200363	90200363	90200363
Stroke length adjustment 	with position indicator	▲	▲	▲	▲	▲
Stroke frequency monitoring 	Inductive contact					
	10-60 V DC, three-wire, PNP	▲	▲	▲	▲	▲
	Namur execution, II2G EEExia IIC T6 acc. to ATEX95	▲	▲	▲	▲	▲
Drive motor 	Special voltage	▲	▲	▲	▲	▲
	Enclosure IP 65	▲	▲	▲	▲	▲
	Protective roof for the fan of the drive	▲	▲	▲	▲	▲
	Integrated posistor (3 pcs.) insul. cl. F	▲	▲	▲	▲	▲
	VIK-design	▲	▲	▲	▲	▲
	II2G EEExde IIT4 (acc. to ATEX95)	▲	▲	▲	▲	▲
	II2G EEExde IIC T4 (acc. to ATEX95)	▲	▲	▲	▲	▲
	Single phase AC 230 V with capacitor	▲	▲	▲	▲	▲
	Driver for converter operation incl. integrated posistor, 5-50/60Hz	▲	▲	▲	▲	▲
Driver for converter operation II2G EEExde IIC T4, 5-50/60 Hz gem. ATEX 95, incl. integrated posistor	▲	▲	▲	▲	▲	
● = Basic design ▲ = with add. price ○ = without add. price © = on request – = not available Art.-Nr. = available in basic design/accessories						

Order information

Basic design

R409.2-18e to R409.2-25

- Pump body PP-FRP
- Double valves PP-FRP
- Valve balls glass
- Valve seals FPM
- Working diaphragm PTFE-faced

R409.2-50e to R409.2-90e and R409.2-140

- Pump body PP-FRP
- Single valves PP-FRP
- Valve balls glass
- Valve seals FPM
- Working diaphragm PTFE-faced

R409.2-115e and R409.2-180e

- Pump body PP-FRP
- Single valve PP-FRP
- Valve balls glass
- Valve seals FPM
- Working diaphragm EPDM

R409.2-250e and R409.2-350e

- Pump body PP
- Single valve PP-FRP
- Valve balls glass
- Valve seals FPM
- Working diaphragm PTFE-faced

Motor:



- 220-240/380-420 V +/- 5% threephase, 50/60 Hz, IP 55, insul. cl. F

Further options and accessories

- Connection pieces see chapter 4
- Product documentation see chapter 5

Type	Basic design	x
R409.2-18e	16005264	
R409.2-25e	16005265	
R409.2-50e	16005266	
R409.2-75e	16005267	
R409.2-90e	16005268	
R409.2-115e	16005269	
R409.2-140e	16005270	
R409.2-180e	16005271	
R409.2-250e	16005280	
R409.2-350e	16005281	

Options/Accessories

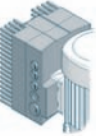
		R409.2-18e R409.2-25e	x	R409.2-50e R409.2-75e	x	R409.2-90e R409.2-140e	x	R409.2-115e R409.2-180e	x	R409.2-250e R409.2-350e	x
Stroke length adjustment electrical 	Actuator N C1-BA 230 V, +/- 10%, 50/60 Hz, 128s/10 U, 1,5 Nm, incl. mounting plate for actuator	▲		▲		▲		▲		▲	
	Electronic positioning controller PMR3 input signal 0/4-20 mA incl. feedback signal 0/4-20 mA (only in N C1-BA integrated)	▲		▲		▲		▲		▲	
	Actuator D30D-10-Ex (II2G EExde IICT4) acc. to ATEX 95, 400 V, 50 Hz, 10 U/min, incl. mounting-kit for actuator and base plate	▲		▲		▲		▲		▲	
Stroke length adjustment pneumatical 	Actuator WPD-4P-60 positioning controller CT 720 control air 6 bar, intake air pressure 3-10 bar IP 65, incl. mounting kit for actuator	▲		▲		▲		▲		▲	
Stroke frequency adjustment electrical 	Frequency converter series 8200 Motec mounted-on, input 4-20mA										
	Single-phase 0.25 kW 230 V, 50/60 Hz	▲		-		-		-		-	
	0.37 kW	-		▲		▲		▲		▲	
	Three-phase 0.55 kW 320-550 V, +/- 0%, 50/60 Hz	▲		▲		▲		▲		▲	
	Switch-potentiometer for manual stroke frequency adjustment and to switch on the pump motor (External control of the frequency converter with mounted switch potentiometer unit is not possible)	▲		▲		▲		▲		▲	
Service module hand terminal and keypad incl. 2,5m connection cable	▲		▲		▲		▲		▲		
<p>● = Basic design ▲ = with add. price ○ = without add. price ⊕ = on request -- = not available Art.-Nr. = available in basic design/accessories</p>											

Order information

Basic design

R409.2-18e to R409.2-25

- Pump body PP-FRP
- Double valves PP-FRP
- Valve balls glass
- Valve seals FPM
- Working diaphragm PTFE-faced

R409.2-50e to R409.2-90e and R409.2-140

- Pump body PP-FRP
- Single valves PP-FRP
- Valve balls glass
- Valve seals FPM
- Working diaphragm PTFE-faced

R409.2-115e and R409.2-180e

- Pump body PP-FRP
- Single valve PP-FRP
- Valve balls glass
- Valve seals FPM
- Working diaphragm EPDM

R409.2-250e and R409.2-350e

- Pump body PP
- Single valve PP-FRP
- Valve balls glass
- Valve seals FPM
- Working diaphragm PTFE-faced

Motor:

- 220-240/380-420 V +/- 5% threephase, 50/60 Hz, IP 55, insul. cl. F

Further options and accessories

- Connection pieces see chapter 4
- Product documentation see chapter 5

Type	Basic design	x
R409.2-18e	16005264	
R409.2-25e	16005265	
R409.2-50e	16005266	
R409.2-75e	16005267	
R409.2-90e	16005268	
R409.2-115e	16005269	
R409.2-140e	16005270	
R409.2-180e	16005271	
R409.2-250e	16005280	
R409.2-350e	16005281	

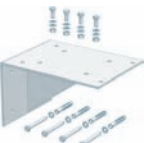
Options/Accessories		R409.2-18e		R409.2-50e		R409.2-90e		R409.2-115e		R409.2-250e		
		R409.2-25e	x	R409.2-75e	x	R409.2-140e	x	R409.2-180e	x	R409.2-350e	x	
Stroke frequency adjustment electrical 	Frequency converter series 8200 Vector input 4-20mA, incl. Keypad (for integration into control cabinet)											
	Single-phase 230 V, 50/60 Hz	0.25 kW	90017521		–		–		–		–	
		0.37 kW	–		90017522		90017522		90017522		90017522	
Three-phase 320-550 V, +/- 0%, 50/60 Hz	0.55 kW	90017526		90017526		90017526		90017526		90017526		
Console 	for wall mounting incl. fixing screws											
		1.4301	90023875		90023875		90023875		90023875		90023875	
		PP	90023848		90023848		90023848		90023848		90023848	
● = Basic design ▲ = with add. price ○ = without add. price © = on request – = not available Art.-Nr. = available in basic design/accessories												

Fittings for suction side of dosing pumps		R409.2-18e R409.2-25e		R409.2-50e		R409.2-75e R409.2-90e		R409.2-115e up to R409.2-180e		R409.2-250e R409.2-350e	
		Type	p.	Type	p.	Type	p.	Type	p.	Type	p.
Suction lance	with level switch 1-stage	SL-11.1	3.36	SL-02	3.34	SL-02	3.34	3.34		S-04	3.40
		S-03	3.38	S-03	3.38	S-03	3.38	S-03	3.38	∅	
	with level switch 2-stage	SL-12.1	3.36	SL-02	3.34	SL-02	3.34	SL-02	3.34	∅	
		without level switch	S-01	3.42	S-01	3.42	S-01	3.42	S-01	3.42	S-01
Suction aid / Siphon Vessel	transparent PVC-U	770.2	3.74	770.2	3.74	770.2	3.74	770.2	3.74	770.2	3.74
Calibration Pot	PVC-U	792.1	3.76	792.1	3.76	793.1	3.76	794.1	3.76	795.1	3.76
Foot valve	PVC-U	731	3.78	731	3.78	731	3.78	731	3.78	732.2	3.80
	PP / PVDF	∅		∅		∅		∅		732	3.78
	PP-FRP / PVDF-FRP	781.1	3.82	781.1	3.82	781.1	3.82	781.1	3.82	783.1	3.82
	1.4571	731	3.78	731	3.78	731	3.78	731	3.78	732	3.78
Line strainer	PVC-U / PP / PVDF	752.1	3.84	752.1	3.84	752.1	3.84	752.1	3.84	752.1	3.84
	PVC-U	751.1	3.84	751.1	3.84	751.1	3.84	751.1	3.84	∅	
	1.4408	752	3.86	752	3.86	752	3.86	752	3.86	752	3.86
Float valve	PVC-U	871	3.88	871	3.88	871	3.88	871	3.88	872	3.88
Pulsation damper without separating diaphragm	PVC-U / PP	702.1	3.14	702.1	3.14	702.1	3.14	702.1	3.14	702.1	3.14
	1.4571	802.1	3.18	802.1	3.18	802.1	3.18	802.1	3.18	802.1	3.18
Fittings for pressure side of dosing pumps		R409.2-18e R409.2-25e		R409.2-50e		R409.2-75e R409.2-90e		R409.2-115e up to R409.2-180e		R409.2-250e R409.2-350e	
		Type	p.	Type	p.	Type	p.	Type	p.	Type	p.
Diaphragm-type relief valve		620.10	3.4	620.10	3.4	622.10	3.4	622.10	3.4	622.10	3.4
	for suspension	∅		∅		622.S	3.6	622.S	3.6	622.S	3.6
Diaphragm-type pressure keeping valve		620.D	3.8	620.D	3.8	622.D	3.8	622.D	3.8	622.D	3.8
Multi-function valve	4 bar opening pressure	MFV 05004	3.10	MFV 05004	3.10	–		–		–	
	6 bar opening pressure	MFV 05006	3.10	MFV 05006	3.10	–		–		–	
	10 bar opening pressure	MFV 05010	3.10	MFV 05010	3.10	–		–		–	
Pulsation damper without separating diaphragm	PVC-U / PP	702.1	3.14	702.1	3.14	702.1	3.14	702.1	3.14	702.1	3.14
	1.4571	802.1	3.18	802.1	3.18	802.1	3.18	802.1	3.18	802.1	3.18
Diaphragm-pulsation damper with PTFE/PTFE- faced diaphragm	PVC-U / PP / PVDF	720.1	3.24	721.2	3.24	722.1	3.24	722.1	3.24	723.1	3.24
	1.4571	721.1	3.28	721.1	3.28	722.1	3.28	722.1	3.28	723.1	3.28
Diaphragm-pulsation damper with Elastomer- diaphragm	PVC-U / PP / PVDF	∅		∅		∅		∅		713.1	3.20
	1.4571	810.1- 0,16/180	3.30	810.1- 0,16/180	3.30	810.1- 0,32/160	3.30	810.1- 0,32/160	3.30	810.1- 0,75/140	3.30
Check valve	PVC-U	661.2	3.48	661.2	3.48	661.2	3.48	661.2	3.48	∅	
	PP-FRP / PVDF-FRP	661.2	3.48	661.2	3.48	661.2	3.48	661.2	3.48	663.2	3.48
	1.4571	661.2	3.48	661.2	3.48	661.2	3.48	661.2	3.48	662.2	3.48
Dosing valve	PVC-U / PP / PVDF	691.1	3.54	691.1	3.54	691.1	3.54	691.1	3.54	∅	
	PVC-U	681.1	3.58	681.1	3.58	681.1	3.58	681.1	3.58	682.1	3.58
	PP-FRP / PVDF-FRP	691.1	3.54	691.1	3.54	691.1	3.54	691.1	3.54	693.1	3.54
	1.4571	691.1	3.54	691.1	3.54	691.1	3.54	691.1	3.54	692.1	3.54
Injection fitting	PVC-U / PP / PVDF	8061.1	3.60	8061.1	3.60	8061.1	3.60	8061.1	3.60	8062.1	3.60

∅ = on request – = not available

The above allocation considers the fittings which have to be used at least regarding their nominal width in order to ensure the safe and trouble-free operation of the respective pumps when feeding liquids which are resembling to water.

Absolutely note the max. admissible operating pressure of the fittings.

The use of fittings of a bigger nominal width is unproblematically possible in most cases.

When choosing the fittings note the installation instructions for dosing pumps or confer with s e r a.

R410.2



R 410.2 in survey

- Compact design
- Little weight
- Safe to run dry
- Leakage-free
- Low maintenance
- User-friendly
- High dosing accuracy
- Integratable into automatic processes
- Manual stroke length adjustment
- Robust metallic stroke mechanism housing

Infobox

- Order information [Page 2.55](#)
- Options/accessories [Page 2.55](#)
- fittings-allocation [Page 2.59](#)
- connecting pieces [Chapter 4](#)
- resistance chart [Chapter 5](#)
- installation examples [Chapter 5](#)

Technical data

Type	Nominal capacity		Nominal stroke frequency		Admissible counter-pressure	Admissible pressure at pump inlet	Max. suction height	Inlet/Outlet nominal width	Max. stroke length	Motor output
	l/h		1/min							
	50 Hz	60 Hz	50 Hz	60 Hz						
R410.2-200e	0 - 200	0 - 240	76	92	8	-0.5 / 0	5	15	13	0.75
R410.2-280e	0 - 280	0 - 336	97	116	8	-0.5 / 0	5	15	13	0.75
R410.2-450e	0 - 450	0 - 540	76	92	6	-0.5 / 0	5	15	13	0.75
R410.2-570e	0 - 570	0 - 684	97	116	6	-0.5 / 0	5	15	13	0.75
R410.2-700e	0 - 700	0 - 840	76	92	5	-0.3 / 0	3	20	13	0.75
R410.2-900e	0 - 900	0 - 1.080	97	116	5	-0.3 / 0	3	20	13	0.75
R410.2-1100e	0 - 1.100	0 - 1.320	76	92	5	-0.3 / 0	3	25	20	1.5
R410.2-1450e	0 - 1.450	—	97	—	5	-0.3 / 0	3	25	20	1.5

e in type designation means: pump with single diaphragm

Dimensional drawing

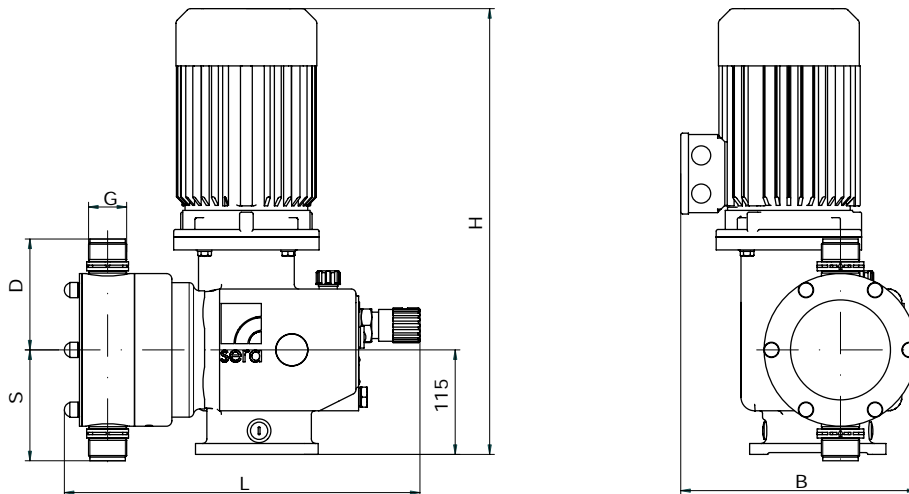

Dimensional chart

All indications in mm

Type	G	S	D	L	B	H	Weight kg
R410.2-200e	G 1 1/4	122	122	405	275	490	29
R410.2-280e	G 1 1/4	122	122	405	275	490	29
R410.2-450e	G 1 1/4	122	122	405	275	490	29
R410.2-570e	G 1 1/4	122	122	405	275	490	29
R410.2-700e	G 1 1/4	142	142	480	330	525	33
R410.2-900e	G 1 1/4	142	142	480	330	525	33
R410.2-1100e	G 1 1/4	142	142	480	330	525	35
R410.2-1450e	G 1 1/4	142	142	480	330	525	35

Indication of weight for Basic design acc. to order information

Order information

Basic design

R410.2-200e to R410.2-1450e

- Pump body PP
- single valve PP-FRP
- Valve balls glass
- Valve seals FPM
- Working diaphragm PTFE-faced







Motor:

- 220-240/380-420 V +/- 5% threephase, 50/60 Hz, IP 55, insul. cl. F

Further options and accessories

- Connection pieces see chapter 4
- Product documentation see chapter 5

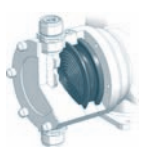
Type	Basic design	x
R410.2-200e	16005245	
R410.2-280e	16005282	
R410.2-450e	16005283	
R410.2-570e	16005284	
R410.2-700e	16005235	
R410.2-900e	16005285	
R410.2-1100e	16005286	
R410.2-1450e	16005287	

Options/Accessories			R410.2-200e R410.2-280e	x	R410.2-450e R410.2-570e	x	R410.2-700e R410.2-900e	x	R410.2-1100e R410.2-1450e	x
Pump body and valves 	PP	single valves PP-FRP	●		●		●		●	
	PVC-U	single valves PVC-U	▲		▲		▲		▲	
	PVDF	single valves PVDF-FRP	▲		▲		▲		▲	
	1.4571	single valves 1.4571/1.4581	▲		▲		▲		▲	
Valve balls 	Glass	single valves	●		●		●		●	
	1.4401	single valves	▲		▲		▲		▲	
	PTFE	single valves	▲		▲		▲		▲	
Valve sealings 	FPM	single valves	●		●		●		●	
	EPDM	single valves	○		○		○		○	
	FEP-covered	single valves	▲		▲		▲		▲	
Integrated relief valve 	with PTFE-faced diaphragm, connection seal FPM or EPDM at pump body made of:									
	PP		▲		▲		–		–	
	PVC-U		▲		▲		–		–	
	PVDF		⊙		⊙		–		–	
	1.4571		▲		▲		–		–	
	Connection seals FEP-covered			▲		▲		–		–
Double diaphragm design 	with intermediate diaphragm made of:									
	CSM		▲		▲		▲		▲	
	PTFE		⊙		⊙		⊙		⊙	
	PTFE-faced		▲		▲		▲		▲	
Diaphragm rupture monitoring 	Diaphragm rupture electrode conductive, mounted to pump									
	MBE-02	for single diaphragm pump	▲		▲		▲		▲	
	MBE-04	for double diaphragm pump	▲		▲		▲		▲	

● = Basic design ▲ = with add. price ○ = without add. price ⊙ = on request – = not available Art.-Nr. = available in basic design/accessories

R410.2

Order information

Basic design

R410.2-200e to R410.2-1450e

- Pump body PP
- Single valve PP-FRP
- Valve balls glass
- Valve seals FPM
- Working diaphragm PTFE-faced





Motor:

- 220-240/380-420 V +/- 5% threephase, 50/60 Hz, IP 55, insul. cl. F

Further options and accessories

- Connection pieces see chapter 4
- Product documentation see chapter 5

Type	Basic design	x
R410.2-200e	16005245	
R410.2-280e	16005282	
R410.2-450e	16005283	
R410.2-570e	16005284	
R410.2-700e	16005235	
R410.2-900e	16005285	
R410.2-1100e	16005286	
R410.2-1450e	16005287	

Options/Accessories		R410.2-200e R410.2-280e x	R410.2-450e R410.2-570e x	R410.2-700e R410.2-900e x	R410.2-1100e R410.2-1450e x	
Diaphragm rupture monitoring 	ATEX-Design (Type examination, only for Double diaphragm design) Diaphragm rupture monitoring, konduktiv, mounted on the pump					
	MBE-04 incl. Connection cable for Diaphragm rupture monitoring blue for EExia-circuit (5m)	▲	▲	▲	▲	
	Buffer fluid glycol-glycerine-mixture 1:25 for media with conductivity $\leq 5\mu\text{S}/\text{cm}$	▲	▲	▲	▲	
Diaphragm rupture monitoring 	Electrode relay, control cabinet assembly					
	ER-104/C	aux. energy 230 V AC	90022994	90022994	90022994	90022994
		aux. energy 24 V DC	90022945	90022945	90022945	90022945
	ER-142	aux. energy 230 V AC II(1)G [EExia] IIC acc. to ATEX 95	90200363	90200363	90200363	90200363
Stroke length adjustment 	with position indicator	▲	▲	▲	▲	
Stroke frequency monitoring 	Induktiv-Kontakt					
	10-60 V DC, three-wire, PNP	▲	▲	▲	▲	
	Namur execution, II2G EExia IICT6 acc. to ATEX95	▲	▲	▲	▲	
Drive motor 	Special voltage	▲	▲	▲	▲	
	Enclosure IP 65	▲	▲	▲	▲	
	Protective roof for the fan of the drive	▲	▲	▲	▲	
	Integrated posistor (3 pcs.) insul. cl. F	▲	▲	▲	▲	
	VIK-design	▲	▲	▲	▲	
	II2G EExde IIT4 (acc. to ATEX95)	▲	▲	▲	▲	
	II2G EExde IICT4 (acc. to ATEX95)	▲	▲	▲	▲	
	Single phase AC 230 V with capacitor	▲	▲	▲	▲	
	Driver for converter operation incl. integrated posistor, 5-50/60Hz	▲	▲	▲	Ⓞ	
Driver for converter operation II2G EExde IICT4, 5-50/60 Hz gem. ATEX 95, incl. integrated posistor	▲	▲	▲	▲		
● = Basic design ▲ = with add. price ○ = without add. price Ⓞ = on request – = not available Art.-Nr. = available in basic design/accessories						

Order information

Basic design

R410.2-200e to R410.2-1450e

- Pump body PP
- single valve PP-FRP
- Valve balls glass
- Valve seals FPM
- Working diaphragm PTFE-faced





Motor:

- 220-240/380-420 V +/- 5% threephase, 50/60 Hz, IP 55, insul. cl. F

Further options and accessories

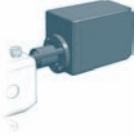
- Connection pieces see chapter 4
- Product documentation see chapter 5

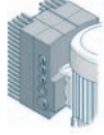
Type	Basic design	x
R410.2-200e	16005245	
R410.2-280e	16005282	
R410.2-450e	16005283	
R410.2-570e	16005284	
R410.2-700e	16005235	
R410.2-900e	16005285	
R410.2-1100e	16005286	
R410.2-1450e	16005287	

Options/Accessories		R410.2-200e		R410.2-450e		R410.2-700e		R410.2-1100e	
		R410.2-280e	x	R410.2-570e	x	R410.2-900e	x	R410.2-1450e	x
Stroke length adjustment electrical 	Actuator N1S 230 V, 50/60 Hz, 128s/10 U, 15 Nm Potentiometer 1 kOhm incl. mounting kit for actuator	▲		▲		▲		▲	
	Electronic positioning controller PMR3 input signal 0/4-20 mA incl. feedback signal 0/4-20 mA (only in N 1S integrated)	▲		▲		▲		▲	
	Actuator D30D-10-Ex (II2G EExde IICT4) acc. to ATEX 95, 400 V, 50 Hz, 10 U/min, incl. mounting-kit for actuator and base plate	▲		▲		▲		▲	
Stroke length adjustment pneumatical 	Actuator WPD-4P-150 positioning controller CT 720 control air 6 bar, intake air pressure 3-10 bar, IP 65, incl. mounting kit for actuator	▲		▲		▲		▲	
Stroke frequency adjustment electrical 	Frequency converter series 8200 Motec mounted-on, input 4-20mA								
	Three-phase 0,75 kW 320-550 V, +/- 0%, 50/60 Hz	▲		▲		-		-	
	Three-phase 1,5 kW 320-550 V, +/- 0%, 50/60 Hz	-		-		▲		▲	
	Switch-potentiometer for manual stroke frequency adjustment and to switch on the pump motor (External control of the frequency converter with mounted switch potentiometer unit is not possible)	▲		▲		▲		▲	
	Service module hand terminal and keypad incl. 2,5m connection cable	▲		▲		▲		▲	
Stroke frequency adjustment electrical 	Frequency converter series 8200 Vector input 4-20mA, incl. Keypad (for integration into control cabinet)								
	Single-phase 0.75 kW 230 V, 50/60 Hz	90017524		90017524		-		-	
	Single-phase 1.5 kW 230 V, 50/60 Hz	-		-		90016885		90016865	
	Three-phase 0.75 kW 320-550 V, +/- 0%, 50/60 Hz	90017527		90017527		-		-	
	Three-phase 1.5 kW 320-550 V, +/- 0%, 50/60 Hz	-		-		90017528		90017528	
● = Basic design ▲ = with add. price ○ = without add. price ⊕ = on request - = not available Art.-Nr. = available in basic design/accessories									

R410.2

Order information

Basic design

R410.2-200e to R410.2-1450e

- Pump body PP
- Single valve PP-FRP
- Valve balls glass
- Valve seals FPM
- Working diaphragm PTFE-faced

Motor:

- 220-240/380-420 V +/- 5% threephase, 50/60 Hz, IP 55, insul. cl. F

Further options and accessories

- Connection pieces see chapter 4
- Product documentation see chapter 5

Type	Basic design	x
R410.2-200e	16005245	
R410.2-280e	16005282	
R410.2-450e	16005283	
R410.2-570e	16005284	
R410.2-700e	16005235	
R410.2-900e	16005285	
R410.2-1100e	16005286	
R410.2-1450e	16005287	

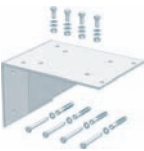
Options/Accessories	R410.2-200e	R410.2-450e	R410.2-700e	R410.2-1100e
	R410.2-280e x	R410.2-570e x	R410.2-900e x	R410.2-1450e x
Console  <p>1.4301 for wall mounting incl. fixing screws</p>	90023876	90023876	90023876	90023876
PP	90023849	90023849	90023849	90023849

● = Basic design ▲ = with add. price ○ = without add. price ⊗ = on request – = not available Art.-Nr. = available in basic design/accessories

2

Fittings for suction side of dosing pumps		R410.2-200e R410.2-280e		R410.2-450e R410.2-570e		R410.2-700e R410.2-900e		R410.2-1100e R410.2-1450e	
		Type	p.	Type	p.	Type	p.	Type	p.
Suction lance	with level switch 1-stage	S-04	3.40	S-04	3.40	⊙		⊙	
	without level switch	S-01	3.42	S-01	3.42	S-01	3.42	⊙	
Suction aid / Siphon Vessel	transparent PVC-U	770.2	3.74	770.2	3.74	771.2	3.74	772.2	3.74
Calibration Pot	PVC-U	795.1	3.76	795.1	3.76	796.1	3.76	796.1	3.76
Foot valve	PVC-U	732.2	3.80	732.2	3.80	733.2	3.80	733.2	3.80
	PP / PVDF	732	3.78	732	3.78	733	3.78	733	3.78
	PP-FRP / PVDF-FRP	783.1	3.82	783.1	3.82	783.1	3.82	783.1	3.82
	1.4571	732	3.78	732	3.78	733	3.78	733	3.78
Lline strainer	PVC-U / PP / PVDF	752.1	3.84	752.1	3.84	753.1	3.84	754.1	3.84
	1.4408	752	3.86	752	3.86	753	3.86	754	3.86
Float valve	PVC-U	872	3.88	872	3.88	873	3.88	874	3.88
Pulsation damper without separating diaphragm	PVC-U / PP	702.1	3.14	702.1	3.14	703.1	3.14	706.1	3.14
	1.4571	802.1	3.18	802.1	3.18	803.1	3.18	804.1	3.18
Fittings for pressure side of dosing pumps		R410.2-200e R410.2-280e		R410.2-450e R410.2-570e		R410.2-700e R410.2-900e		R410.2-1100e R410.2-1450e	
		Type	p.	Type	p.	Type	p.	Type	p.
Diaphragm-type relief valve		622.10	3.4	622.10	3.4	623.10	3.4	624.10	3.4
	for suspension	622.S	3.6	622.S	3.6	623.S	3.6	624.S	3.6
Diaphragm-type pressure keeping valve		622.D	3.8	622.D	3.8	623.D	3.8	624.D	3.8
Pulsation damper without separating diaphragm	PVC-U / PP	702.1	3.14	702.1	3.14	703.1	3.14	706.1	3.14
	1.4571	802.1	3.18	802.1	3.18	803.1	3.18	804.1	3.18
Diaphragm-pulsation damper with Elastomer-diaphragm	PVC-U / PP / PVDF	713.1	3.20	713.1	3.20	713.1	3.20	713.1	3.20
	1.4571	810.1-0,75/140	3.30	810.1-2,0/100	3.30	810.1-2,0/100	3.30	713.1	3.22
Diaphragm-pulsation damper with PTFE/PTFE-faced diaphragm	PVC-U / PP / PVDF	723.1	3.24	⊙		⊙		⊙	
	1.4571	723.1	3.28	724.1	3.28	724.1	3.28	⊙	
Check valve	PP-FRP / PVDF-FRP	663.2	3.48	663.2	3.48	663.2	3.48	663.2	3.48
	1.4571	662.2	3.48	662.2	3.48	663.2	3.48	663.2	3.48
Dosing valve	PVC-U / PP / PVDF	682.1	3.58	682.1	3.58	683.1	3.58	684.1	3.58
	PP-FRP / PVDF-FRP	693.1	3.54	693.1	3.54	693.1	3.54	693.1	3.54
	1.4571	692.1	3.54	692.1	3.54	693.1	3.54	693.1	3.54
Injection fitting	PVC-U / PP / PVDF	8062.1	3.60	8062.1	3.60	8063.1	3.60	8063.1	3.60

⊙ = on request

The above allocation considers the fittings which have to be used at least regarding their nominal width in order to ensure the safe and trouble-free operation of the respective pumps when feeding liquids which are resembling to water.

Absolutely note the max. admissible operating pressure of the fittings.

The use of fittings of a bigger nominal width is unproblematically possible in most cases.

When choosing the fittings note the installation instructions for dosing pumps or confer with s e r a.



M/R 414 in survey

- Leakage-free
- High dosing accuracy
- Safe to run dry
- High quality materials
- Low-maintenance
- User-friendly
- Integrateable into automatic processes
- Manual stroke frequency adjustment
- Robust metallic stroke mechanism housing

Infobox

- Order information [Page 2.61](#)
- Options/accessories [Page 2.61](#)
- fittings-allocation [Page 2.64](#)
- connecting pieces [Chapter 4](#)
- resistance chart [Chapter 5](#)
- installation examples [Chapter 5](#)

Technical data

Type	Nominal capacity l/h 50 Hz/60 Hz	Nominal stroke frequency 1/min		Admissible counterpressure bar	Admissible pressure at pump inlet bar	Max. suction height mWS	Inlet/ Outlet nominal width DN	Max. stroke length mm	Motor output kW
		50 Hz	60 Hz						
M414	2,000	50	50	3	-0.3 / 0	3	32	30	0.75
R414	400 - 2.000	50	50	3	-0.3 / 0	3	32	30	0.75

Dimensional drawing

Manual stroke frequency adjustment
(Gear unit)

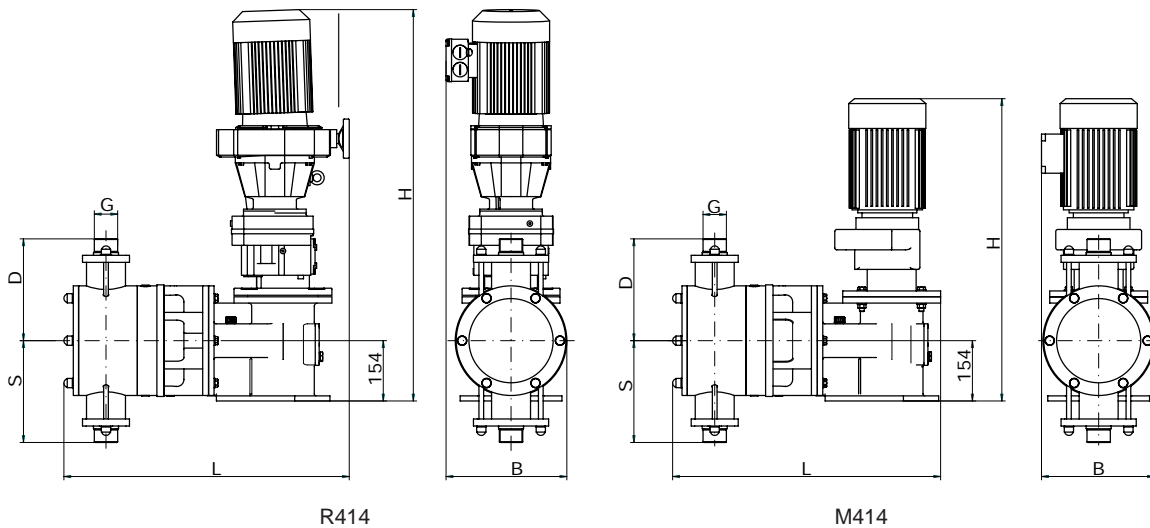

Dimensional chart

All indications in mm

Type	G	S	D	L	B	H	Weight kg
M414	G 2	260	260	688	280	685	125
R414	G 2	260	260	739	280	865	145

Indication of weight for Basic design acc. to order information

Order information

Basic design

M/R414

- Pump body PP
- Single valves PP
- Intermediate diaphragm PTFE-faced
- Valve balls PTFE
- Valve seals FPM





Motor:

- 230/400 V threephase, 50/60 Hz, IP 55, insul. cl. F

Further options and accessories:

- Connection pieces see chapter 4
- Product documentation see chapter 5

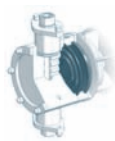
Type	Basic design	x
M414	16000327	
R414	16003820	

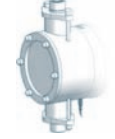
Options/Accessories			M414 R414	x
Pump body and valves 	PP	single valves PP	●	
	PVDF	single valves PVDF	▲	
	1.4571, welded	single valves	▲	
Valve balls 	1.4401	single valves	–	
	PTFE	single valves	●	
Valve sealings 	FPM	single valves	●	
	EPDM	single valves	○	
	FEP-covered	single valves	▲	
Double diaphragm design 	with intermediate diaphragm made of:			
	CSM		▲	
	PTFE		▲	
Diaphragm rupture monitoring 	Diaphragm rupture electrode conductive, mounted to pump			
	MBE-04		▲	
Diaphragm rupture monitoring 	ATEX-Design (Type examination, only for Double diaphragm design) Diaphragm rupture monitoring, konduktiv, mounted on the pump			
	MBE-04 incl. Connection cable for Diaphragm rupture monitoring blue for EExia-circuit (5m)		▲	
	Buffer fluid glycol-glycerine-mixture 1:25 for media with conductivity $\leq 5\mu\text{S/cm}$		▲	
● = Basic design ▲ = with add. price ○ = without add. price Ⓞ = on request – = not available Art.-Nr. = available in basic design/accessories				

Order information

Basic design

M/R414:

- Pump body PP
- Single valves PP
- Intermediate diaphragm PTFE-faced
- Valve balls PTFE
- Valve seals FPM



Motor:

- 230/400 V threephase, 50/60 Hz, IP 55, insul. cl. F

Further options and accessories:

- Connection pieces see chapter 4
- Product documentation see chapter 5

Type	Basic design	x
M414	16000327	
R414	16003820	

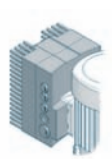
Options/Accessories		M414 R414	x
Diaphragm rupture monitoring 	Electrode relay, control cabinet assembly		
	ER-104/C	aux. energy 230 V AC	90022994
		aux. energy 24 V DC	90022945
	ER-142	aux. energy 230 V AC II(1)G [EExia] IIC acc. to ATEX 95	90200363
Stroke frequency monitoring 	Reed-contact (max. switching capacity 10 VA)		
	Enclosure IP 65	▲	
	Ex-design: II2G EExm IIBT6 acc. to ATEX95	▲	
Drive motor 	Special voltage	▲	
	Enclosure IP 65	▲	
	Protective roof for the fan of the drive	▲	
	Integrated posistor (3 pcs.) insul. cl. F	▲	
	VIK-design	▲	
	II2G EExe IIT3 (acc. to ATEX95)	⊙	
	II2G EExe IIT4 (acc. to ATEX95)	⊙	
	II2G EExde IICT4 (acc. to ATEX95)	⊙	
	Driver for converter operation i ncl. integrated posistor, 5-50/60Hz (not for Gear unit)	▲	
Driver for converter operation II2G EExde IICT4, 5-50/60 Hz gem. ATEX 95, incl. integrated posistor	⊙		
Stroke frequency adjustment electrical 	Frequency converter series 8200 Motec mounted-on, input 4-20mA		
	Three-phase 320-550 V, +/- 0%, 50/60 Hz 1,5 kW	▲	
	Switch-potentiometer for manual stroke frequency adjustment and to switch on the pump motor (External control of the frequency converter with mounted switch potentiometer unit is not possible)	▲	
	Service module hand terminal and keypad incl. 2,5m connection cable	▲	
● = Basic design ▲ = with add. price ○ = without add. price ⊙ = on request -- = not available Art.-Nr. = available in basic design/accessories			

Order information

Basic design

M/R414:

- Pump body PP
- Single valves PP
- Intermediate diaphragm PTFE-faced
- Valve balls PTFE
- Valve seals FPM

Motor:

- 230/400 V threephase, 50/60 Hz, IP 55, insul. cl. F

Further options and accessories:

- Connection pieces see chapter 4
- Product documentation see chapter 5

Type	Basic design	x
M414	16000327	
R414	16003820	

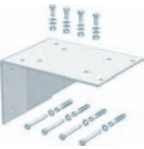
Options/Accessories		M414 R414	x
Stroke frequency adjustment electrical 	Frequency converter series 8200 Vector input 4-20mA, incl. Keypad (for integration into control cabinet)		
	Single-phase 230 V, 50/60 Hz 1.5 kW	90016865	
	Three-phase 320-550 V, +/- 0%, 50/60 Hz 1.5 kW	90017528	
Console 	for wall mounting incl. fixing screws	1.4301	Ⓞ
	PP		Ⓞ
● = Basic design ▲ = with add. price ○ = without add. price Ⓞ = on request – = not available Art.-Nr. = available in basic design/accessories			

Fittings for suction side of dosing pumps		M414 R414	
		Type	p.
Suction aid / Siphon Vessel	transparent PVC-U	772.2	3.74
Calibration Pot	PVC-U	797.1	3.76
Foot valve	PVC-U	735.2	3.80
	PP / PVDF	735	3.78
	1.4571	735	3.78
Line strainer	PVC-U / PP / PVDF	755.1	3.84
	1.4408	755	3.86
Float valve	PVC-U	875	3.88
Pulsation damper without separating diaphragm	PVC-U / PP	706.1	3.14
	1.4571	806.1	3.18
Fittings for pressure side of dosing pumps		M414 R414	
		Type	p.
Diaphragm-type relief valve		625.10	3.4
	for suspension	625.S	3.6
Diaphragm-type pressure keeping valve		625.D	3.8
Pulsation damper without separating diaphragm	PVC-U / PP	706.1	3.14
	1.4571	806.1	3.18
Diaphragm-pulsation damper with Elastomer-diaphragm	PVC-U / PP / PVDF	715.1	3.20
	1.4571	715.1	3.22
Dosing valve	PVC-U / PP / PVDF	685.1	3.58

The above allocation considers the fittings which have to be used at least regarding their nominal width in order to ensure the safe and trouble-free operation of the respective pumps when feeding liquids which are resembling to water.

Absolutely note the max. admissible operating pressure of the fittings.

The use of fittings of a bigger nominal width is unproblematically possible in most cases.

When choosing the fittings note the installation instructions for dosing pumps or confer with s e r a.



M/R 415 in survey

- Leakage-free
- High dosing accuracy
- Safe to run dry
- High quality materials
- Low-maintenance
- User-friendly
- Integrateable into automatic processes
- Manual stroke frequency adjustment
- Robust metallic stroke mechanism housing

Infobox

- Order information [Page 2.67](#)
- Options/accessories [Page 2.67](#)
- fittings-allocation [Page 2.70](#)
- connecting pieces [Chapter 4](#)
- resistance chart [Chapter 5](#)
- installation examples [Chapter 5](#)

Technical data

Type	Nominal capacity l/h	Nominal stroke frequency 1/min		Admissible counter pressure bar	Admissible pressure at pump inlet bar	Max. suction height mWS	Inlet/ Outlet nominal width DN	Max. stroke length mm	Motor output kW	
		50 Hz/60 Hz	50 Hz							60 Hz
M415	4,000		50	50	3	-0.3 / 0	3	40	36	1.5
R415	800 - 4.000		50	50	3	-0.3 / 0	3	40	36	1.5

Dimensional drawing

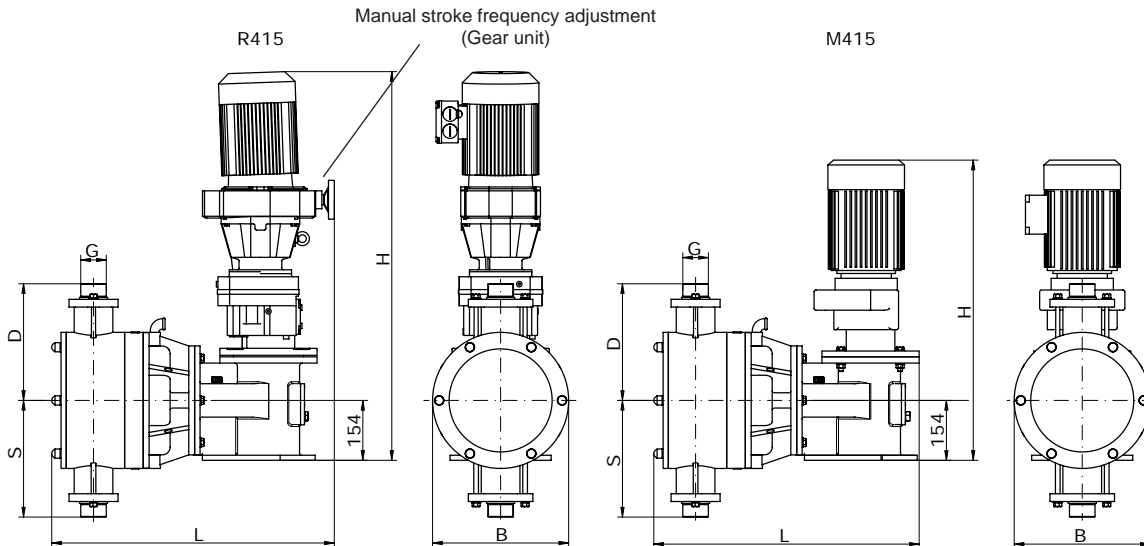

Dimensional chart

All indications in mm

Type	G	S	D	L	B	H	Weight kg
M415	G 2 1/4	300	300	670	350	840	140
R415	G 2 1/4	300	300	750	350	960	160

Indication of weight for Basic design acc. to order information

Order information

Basic design

M/R415

- Pump body PP
- Single valves PP
- Intermediate diaphragm PTFE-faced
- Valve balls PTFE
- Valve seals FPM





Motor:

- 230/400 V threephase, 50/60 Hz, IP 55, insul. cl. F

Further options and accessories

- Connection pieces see chapter 4
- Product documentation see chapter 5

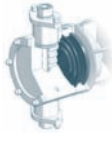
Type	Basic design	x
M415	16000317	
R415	16002641	

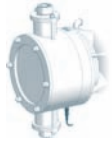
Options/Accessories			M415 R415	x
Pump body and valves 	PP	single valves PP	●	
	PVDF	single valves PVDF	▲	
	1.4571, welded	single valves 1.4571	▲	
Valve balls 	1.4401	single valves	–	
	PTFE	single valves	●	
Valve sealings 	FPM	single valves	●	
	EPDM	single valves	○	
	FEP-covered	single valves	▲	
Double diaphragm design 	with intermediate diaphragm made of:			
	CSM		▲	
	PTFE		▲	
Diaphragm rupture monitoring 	Diaphragm rupture electrode conductive, mounted to pump			
	MBE-04		▲	
Diaphragm rupture monitoring 	ATEX-Design (Type examination, only for Double diaphragm design) Diaphragm rupture monitoring, konduktiv, mounted on the pump			
	MBE-04 incl. Connection cable for Diaphragm rupture monitoring blue for EExia-circuit (5m)		▲	
	Buffer fluid glycol-glycerine-mixture 1:25 for media with conductivity $\leq 5\mu\text{S}/\text{cm}$		▲	
● = Basic design ▲ = with add. price ○ = without add. price ⊕ = on request – = not available Art.-Nr. = available in basic design/accessories				

Order information

Basic design

M/R415

- Pump body PP
- Single valves PP
- Intermediate diaphragm PTFE-faced
- Valve balls PTFE
- Valve seals FPM



Motor:

- 230/400 V threephase, 50/60 Hz, IP 55, insul. cl. F

Further options and accessories

- Connection pieces see chapter 4
- Product documentation see chapter 5

Type	Basic design	x
M415	16000317	
R415	16002641	

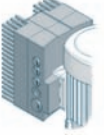
Options/Accessories		M415 R415	x
Diaphragm rupture monitoring 	Electrode relay, control cabinet assembly		
	ER-104/C	aux. energy 230 V AC	90022994
		aux. energy 24 V DC	90022945
	ER-142	aux. energy 230 V AC II(1)G [EExia] IIC acc. to ATEX 95	90200363
Stroke frequency monitoring 	Reed-contact (max. switching capacity 10 VA)		
	Enclosure IP 65	▲	
	Ex-design: II2G EExm IIBT6 acc. to ATEX95	▲	
Drive motor 	Special voltage	▲	
	Enclosure IP 65	▲	
	Protective roof for the fan of the drive	▲	
	Integrated posistor (3 pcs.) insul. cl. F	▲	
	VIK-design	▲	
	II2G EExe IIT3 (acc. to ATEX95)	⊙	
	II2G EExe IIT4 (acc. to ATEX95)	⊙	
	II2G EExde IICT4 (acc. to ATEX95)	⊙	
	Driver for converter operation incl. integrated posistor, 5-50/60Hz (not for gear unit)	▲	
Driver for converter operation II2G EExde IICT4, 5-50/60 Hz gem. ATEX 95, incl. integrated posistor	⊙		
Stroke frequency adjustment electrical 	Frequency converter series 8200 Motec mounted-on, input 4-20mA		
	Three-phase 320-550 V, +/- 0%, 50/60 Hz 2.2 kW	▲	
	Switch-potentiometer for manual stroke frequency adjustment and to switch on the pump motor (External control of the frequency converter with mounted switch potentiometer unit is not possible)	▲	
	Service module hand terminal and keypad incl. 2,5m connection cable	▲	
● = Basic design ▲ = with add. price ○ = without add. price ⊙ = on request -- = not available Art.-Nr. = available in basic design/accessories			

Order information

Basic design

M/R415

- Pump body PP
- Single valves PP
- Intermediate diaphragm PTFE-faced
- Valve balls PTFE
- Valve seals FPM

Motor:

- 230/400 V threephase, 50/60 Hz, IP 55, insul. cl. F

Further options and accessories

- Connection pieces see chapter 4
- Product documentation see chapter 5

Type	Basic design	x
M415	16000317	
R415	16002641	

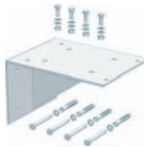
Options/Accessories		M415	R415	x
Stroke frequency adjustment electrical 	Frequency converter series 8200 Vector input 4-20mA, incl. Keypad (for integration into control cabinet)			
	Single-phase 230 V, 50/60 Hz 2.2 kW		90017525	
	Three-phase 320-550 V, +/- 0%, 50/60 Hz 2.2 kW		90017529	
Console 	for wall mounting incl. fixing screws	1.4301	Ⓞ	
		PP	Ⓞ	
● = Basic design ▲ = with add. price ○ = without add. price Ⓞ = on request – = not available Art.-Nr. = available in basic design/accessories				

Fittings for suction side of dosing pumps		M415 R415	
		Type	p.
Suction aid / Siphon Vessel	transparent PVC-U	772.2	3.74
Calibration Pot	PVC-U	797.1	3.76
Foot valve	PVC-U	736.2	3.80
	PP / PVDF	736	3.78
	1.4571	736	3.78
Line strainer	PVC-U / PP / PVDF	756.1	3.84
	1.4408	756	3.86
Lfloat valve	PVC-U	876	3.88
Pulsation damper without separating diaphragm	PVC-U / PP	706.1	3.14
	1.4571	806.1	3.18
Fittings for pressure side of dosing pumps		M415 R415	
		Type	p.
Diaphragm-type relief valve		626.10	3.4
	for suspension	626.S	3.6
Diaphragm-type pressure keeping valve		626.D	3.8
Pulsation damper without separating diaphragm	PVC-U / PP	706.1	3.14
	1.4571	806.1	3.18
Diaphragm-pulsation damper with Elastomer-diaphragm	PVC-U / PP / PVDF	715.1	3.20
	1.4571	715.1	3.22
Dosing valve	PVC-U / PP / PVDF	686.1	3.58

The above allocation considers the fittings which have to be used at least regarding their nominal width in order to ensure the safe and trouble-free operation of the respective pumps when feeding liquids which are resembling to water.

Absolutely note the max. admissible operating pressure of the fittings.

The use of fittings of a bigger nominal width is unproblematically possible in most cases.

When choosing the fittings note the installation instructions for dosing pumps or confer with s e r a.

Diaphragm-multi-headed pumps

Flow capacity 2 x 3,75 l/h ... 2 x 27 l/h

Admissible counterpressure up to 10 bar



ZR408.1



ZR408.1 in survey

- Compact design
- Safe to run dry
- Leakage-free
- Low maintenance
- User-friendly
- High quality materials
- High dosing accuracy
- Integratable into automatic processes
- 2 Manual stroke length adjustment
- Robust metallic stroke mechanism housing
- 2 Dosing heads - 1 drive

Infobox

- Order information [Page 2.73](#)
- Options/accessories [Page 2.73](#)
- fittings-allocation [Page 2.77](#)
- connecting pieces [Chapter 4](#)
- resistance chart [Chapter 5](#)
- installation examples [Chapter 5](#)

Technical data

Type	Nominal capacity		Nominal stroke frequency		Admissible counter-pressure bar	Admissible pressure at pump inlet bar	max. suction height mWS	Inlet/Outlet nominal width DN	Max. stroke length mm	Motor output kW
	l/h		1/min							
	50 Hz	60 Hz	50 Hz	60 Hz						
ZR408.1-3,75e	2 x 0 - 3.75	2 x 0 - 4.5	80	96	10	-0.3 / 0	3	10	4	0.09
ZR408.1-7,5e	2 x 0 - 7.5	2 x 0 - 7.5	156	160	10	-0.3 / 0	3	10	4	0.09
ZR408.1-13e	2 x 0 - 13	2 x 0 - 15.5	80	96	6	-0.3 / 0	3	10	6	0.09
ZR408.1-27e	2 x 0 - 27	2 x 0 - 27	156	160	6	-0.3 / 0	3	10	6	0.09

e in type designation means: pump with single diaphragm

Dimensional drawing

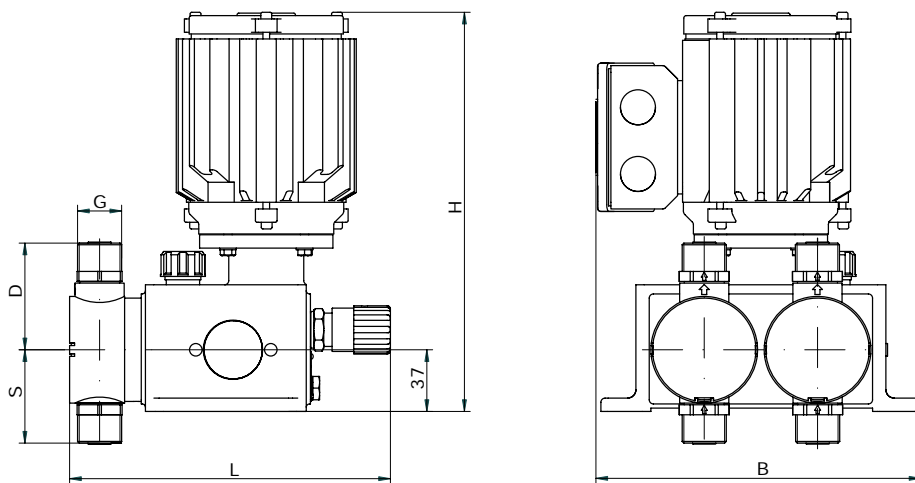

Dimensional chart

All indications in mm

Type	G	S	D	L	B	H	Weight kg
ZR408.1-3,75e	G 3/4	64	56	198	192	275	8
ZR408.1-7,5e	G 3/4	64	56	198	192	275	8
ZR408.1-13e	G 3/4	64	56	200	192	275	8
ZR408.1-27e	G 3/4	64	56	200	192	275	8

Indication of weight for Basic design acc. to order information

Order information

Basic design

ZR408.1:

- Pump bodies PP-FRP
- Double valves PP-FRP
- Valve balls glass
- Valve seals FPM
- Working diaphragms PTFE-faced



Motor:

- 200-254/346-440 V 50 Hz / 200-280/346-480 V 60 Hz threephase, IP 55, insul. cl. F

Further options and accessories:

- Connection pieces see chapter 4
- Product documentation see chapter 5

Type	Basic design	x
ZR408.1-3,75e	16003764	
ZR408.1-7,5e	16003821	
ZR408.1-13e	16003822	
ZR408.1-27e	16003824	

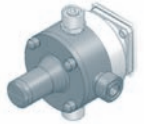
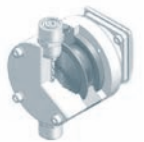
Options/Accessories			ZR408.1-3,75e ZR408.1-7,5e	x	ZR408.1-13e ZR408.1-27e	x
Pump body and valves 	PP-FRP	double valves PP-FRP	●		●	
	PVC-U	single valves PVC-U	▲		▲	
	PVDF	double valves PVDF-FRP	▲		▲	
	PVDF-FRP	double valves PVDF-FRP	▲		▲	
	1.4571	double valves 1.4571/1.4581	▲		▲	
Valve balls 	Glass	single valves	○		○	
		double valves	●		●	
	1.4401	single valves	○		○	
		double valves	○		○	
	PTFE	single valves	▲		▲	
		double valves	▲		▲	
Valve sealings 	FPM	single valves	○		○	
		double valves	●		●	
	EPDM	single valves	○		○	
		double valves	○		○	
	FEP-covered	single valves	▲		▲	
		double valves	▲		▲	
Intergrated relief valve 	with PTFE-faced diaphragm, connection seal FPM or EPDM at pump body made of:					
		PP	▲		▲	
		PVC-U	▲		▲	
		PVDF	⊗		⊗	
		1.4571	▲		▲	
		Connection seals FEP-covered		▲		▲
Double diaphragm design 	with intermediate diaphragm made of:					
		CSM	▲		▲	
		PTFE	⊗		▲	
● = Basic design ▲ = with add. price ⊗ = on request ○ = without add. price Art.-Nr. = available in basic design/accessories						

Diaphragm-multi-headed pumps

Flow capacity 2 x 3,75 l/h ... 2 x 27 l/h
Admissible counterpressure up to 10 bar



ZR408.1

Order information

Basic design

ZR408.1:

- Pump bodies PP-FRP
- Double valves PP-FRP
- Valve balls glass
- Valve seals FPM
- Working diaphragms PTFE-faced



Motor:

- 200-254/346-440 V 50 Hz / 200-280/346-480 V 60 Hz threephase, IP 55, insul. cl. F

Further options and accessories:

- Connection pieces see chapter 4
- Product documentation see chapter 5

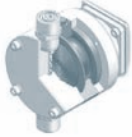
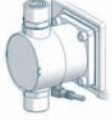
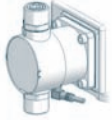
Type	Basic design	x
ZR408.1-3,75e	16003764	
ZR408.1-7,5e	16003821	
ZR408.1-13e	16003822	
ZR408.1-27e	16003824	

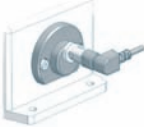
Options/Accessories		ZR408.1-3,75e ZR408.1-7,5e	x	ZR408.1-13e ZR408.1-27e	x
Working diaphragms 	PTFE-faced	●		●	
	FPM	▲		▲	
Diaphragm rupture monitoring 	Diaphragm rupture electrode conductive, mounted to pump				
	MBE-02	for single diaphragm pump	▲		▲
	MBE-03	for double diaphragm pump	▲		▲
Diaphragm rupture monitoring 	ATEX-Design (Type examination, only for Double diaphragm design) Diaphragm rupture monitoring, conductive, mounted on the pump				
	MBE-03 incl. Connection cable for Diaphragm rupture monitoring blue for EExia-circuit (5m)		▲		▲
	Buffer fluid glycol-glycerine-mixture 1:25 for media with conductivity $\leq 5\mu\text{S/cm}$		▲		▲
Diaphragm rupture monitoring 	Electrode relay, control cabinet assembly				
	ER-104/C	aux. energy 230 V AC	90022994		90022994
		aux. energy 24 V DC	90022945		90022945
ER-142	aux. energy 230 V AC II(1)G [EExia] IIC acc. to ATEX 95	90200363		90200363	
Stroke length adjustment 	with position indicator		▲		▲
Stroke frequency monitoring 	Inductive contact				
	10-60 V DC, three-wire, PNP		▲		▲
Namur execution, II2G EExia IIC T6 acc. to ATEX95		▲		▲	
● = Basic design ▲ = with add. price ⊗ = on request ○ = without add. price Art.-Nr. = available in basic design/accessories					

2

Order information

Basic design

ZR408.1:

- Pump bodies PP-FRP
- Double valves PP-FRP
- Valve balls glass
- Valve seals FPM
- Working diaphragms PTFE-faced





Motor:

- 200-254/346-440 V 50 Hz / 200-280/346-480 V 60 Hz threephase, IP 55, insul. cl. F

Further options and accessories:

- Connection pieces see chapter 4
- Product documentation see chapter 5

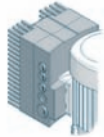
Type	Basic design	x
ZR408.1-3,75e	16003764	
ZR408.1-7,5e	16003821	
ZR408.1-13e	16003822	
ZR408.1-27e	16003824	

Options/Accessories		ZR408.1-3,75e ZR408.1-7,5e	x	ZR408.1-13e ZR408.1-27e	x
Drive motor 	Special voltage	▲		▲	
	Enclosure IP 65	▲		▲	
	Integrated posistor (3 pcs.) insul. cl. F	▲		▲	
	VIK-design	▲		▲	
	II2G EExe IIT4 (acc. to ATEX95)	▲		▲	
	II2G EExde IICT4 (acc. to ATEX95)	▲		▲	
	Single phase AC 230V with capacitor	▲		▲	
	Driver for converter operation incl. posistor, 5-100 Hz	▲		▲	
	Driver for converter operation II2G EExde IICT4, 5-100 Hz gem. ATEX 95, incl. integrated posistor	▲		▲	
Stroke length adjustment electrical 	Actuator N C1-BA 230 V, +/- 10%, 50/60 Hz, 128s/10 U, 1,5 Nm incl. mounting plate for actuator	⊙		⊙	
	Electronic positioning controller PMR3 input signal 0/4-20 mA incl. feedback signal 0/4-20 mA (only in N C1-BA integrated)	⊙		⊙	
Stroke frequency adjustment electrical 	Frequency converter series 8200 Motec mounted-on, input 4-20mA				
	Single-phase 230 V, 50/60 Hz 0.25 kW	▲		▲	
	Three-phase 320-550 V, +/- 0%, 0.55 kW 50/60 Hz	▲		▲	
	Switch-potentiometer for manual stroke frequency adjustment and to switch on the pump motor (External control of the frequency converter with mounted switch potentiometer unit is not possible)	▲		▲	
	Service module hand terminal and keypad incl. 2,5m connection cable	▲		▲	
Stroke frequency adjustment electrical 	Frequency converter series 8200 Vector input 4-20mA, incl. Keypad (for integration into control cabinet)				
	Single-phase 230 V, 50/60 Hz 0.25 kW	90017521		90017521	
	Three-phase 320-550 V, +/- 0%, 0.55 kW 50/60 Hz	90017526		90017526	

● = Basic design

▲ = with add. price

⊙ = on request

○ = without add. price

Art.-Nr. = available in basic design/accessories

Diaphragm-multi-headed pumps

Flow capacity 2 x 3,75 l/h ... 2 x 27 l/h

Admissible counterpressure up to 10 bar



ZR408.1

Order information

Basic design

ZR408.1:

- Pump bodies PP-FRP
- Double valves PP-FRP
- Valve balls glass
- Valve seals FPM
- Working diaphragms PTFE-faced

Motor:

- 200-254/346-440 V 50 Hz / 200-280/346-480 V 60 Hz threephase, IP 55, insul. cl. F

Further options and accessories:

- Connection pieces see chapter 4
- Product documentation see chapter 5

Type	Basic design	x
ZR408.1-3,75e	16003764	
ZR408.1-7,5e	16003821	
ZR408.1-13e	16003822	
ZR408.1-27e	16003824	

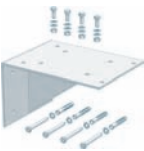
Options/Accessories		ZR408.1-3,75e ZR408.1-7,5e	x	ZR408.1-13e ZR408.1-27e	x
 <p>Console</p> <p>for wall mounting incl. fixing screws</p>	1.4301	⓪		⓪	
	PP	⓪		⓪	
<p>● = Basic design ▲ = with add. price ⓪ = on request ○ = without add. price Art.-Nr. = available in basic design/accessories</p>					

2

Fittings for suction side of dosing pumps		ZR408.1-3,75e ZR408.1-7,5e		ZR408.1-13e ZR408.1-27e	
		Type	p.	Type	p.
Suction lance	with level switch 1-stage	SL-11.1	3.36	SL-11.1	3.36
	with level switch 2-stage	SL-12.1	3.36	SL-12.1	3.36
	without level switch	S-01	3.42	S-01	3.42
Suction aid / Siphon Vessel	transparent PVC-U	770.2	3.74	770.2	3.74
Calibration Pot	PVC-U	791.1	3.76	792.1	3.76
	PVC-U	731	3.78	731	3.78
Foot valve	PP-FRP / PVDF-FRP	781.1	3.82	781.1	3.82
	1.4571	731	3.78	731	3.78
Line strainer	PVC-U	751.1	3.84	751.1	3.84
	PVC-U / PP / PVDF	752.1	3.84	752.1	3.84
Float valve	PVC-U	871	3.88	871	3.88
Pulsation damper without separating diaphragm	PVC-U / PP	702.1	3.14	702.1	3.14
	1.4571	802.1	3.18	802.1	3.18
Fittings for pressure side of dosing pumps		ZR408.1-3,75e ZR408.1-7,5e		ZR408.1-13e ZR408.1-27e	
		Type	p.	Type	p.
Diaphragm-type relief valve		620.10	3.4	620.10	3.4
Diaphragm-type pressure keeping valve		620.D	3.8	620.D	3.8
Multi-function valve	4 bar opening pressure	MFV 05004	3.10	MFV 05004	3.10
	6 bar opening pressure	MFV 05006	3.10	MFV 05006	3.10
	10 bar opening pressure	MFV 05010	3.10	–	
Pulsation damper without separating diaphragm	PVC-U / PP	702.1	3.14	702.1	3.14
	1.4571	802.1	3.18	802.1	3.18
Diaphragm-pulsation damper with PTFE/PTFE-faced diaphragm	PVC-U / PP / PVDF	720.1	3.24	720.1	3.24
	1.4571	721.1	3.28	721.1	3.28
Diaphragm-pulsation damper with Elastomer-diaphragm	1.4571	810.1- 0,16/180	3.30	810.1- 0,16/180	3.30
Check valve	PVC-U	661.2	3.48	661.2	3.48
	PP-FRP / PVDF-FRP	661.2	3.48	661.2	3.48
	1.4571	661.2	3.48	661.2	3.48
Dosing valve	PVC-U	691.1	3.54	691.1	3.54
	PVC-U / PP / PVDF	681.1	3.58	681.1	3.58
	PP-FRP / PVDF-FRP	691.1	3.54	691.1	3.54
	1.4571	691.1	3.54	691.1	3.54
Injection fitting	PVC-U / PP / PVDF	8061.1	3.60	8061.1	3.60

– = not available

The above allocation considers the fittings which have to be used at least regarding their nominal width in order to ensure the safe and trouble-free operation of the respective pumps when feeding liquids which are resembling to water.

Absolutely note the max. admissible operating pressure of the fittings.

The use of fittings of a bigger nominal width is unproblematically possible in most cases.

When choosing the fittings note the installation instructions for dosing pumps or confer with s e r a.

Diaphragm-multi-headed pumps

Flow capacity 2 x 18 l/h ... 2 x 190 l/h

Admissible counterpressure up to 10 bar



ZR409.1



ZR409.1 in survey

- Compact design
- Safe to run dry
- Leakage-free
- Low maintenance
- User-friendly
- High quality materials
- High dosing accuracy
- Integratable into automatic processes
- 2 Manual stroke length adjustment
- Robust metallic stroke mechanism housing
- 2 Dosing heads - 1 drive

Infobox

- Order information [Page 2.79](#)
- Options/accessories [Page 2.79](#)
- fittings-allocation [Page 2.83](#)
- connecting pieces [Chapter 4](#)
- resistance chart [Chapter 5](#)
- installation examples [Chapter 5](#)

Technical data

Type	Nominal capacity		Nominal stroke frequency		Admissible counter-pressure	Admissible pressure at pump inlet	Max. suction height	Inlet/ Outlet nominal width	Max. stroke length	Motor output
	l/h		1/min							
	50 Hz	60 Hz	50 Hz	60 Hz						
ZR409.1-18e	2 x 0 - 18	2 x 0 - 21.5	100	120	10	-0.3 / 0	3	10	6	0.18
ZR409.1-27e	2 x 0 - 27	2 x 0 - 27	160	160	10	-0.3 / 0	3	10	6	0.18
ZR409.1-50e	2 x 0 - 50	2 x 0 - 60	100	120	10	-0.3 / 0	3	10	8	0.18
ZR409.1-75e	2 x 0 - 75	2 x 0 - 75	160	160	10	-0.3 / 0	3	15	8	0.18
ZR409.1-90e	2 x 0 - 90	2 x 0 - 108	100	120	8	-0.3 / 0	3	15	10	0.37
ZR409.1-115e	2 x 0 - 115	2 x 0 - 138	100	120	4	-0.3 / 0	3	15	10	0.18
ZR409.1-150e	2 x 0 - 150	2 x 0 - 150	160	160	8	-0.3 / 0	3	15	10	0.37
ZR409.1-190e	2 x 0 - 190	2 x 0 - 190	160	160	4	-0.3 / 0	3	15	10	0.18

e in type designation means: pump with single diaphragm

Dimensional drawing

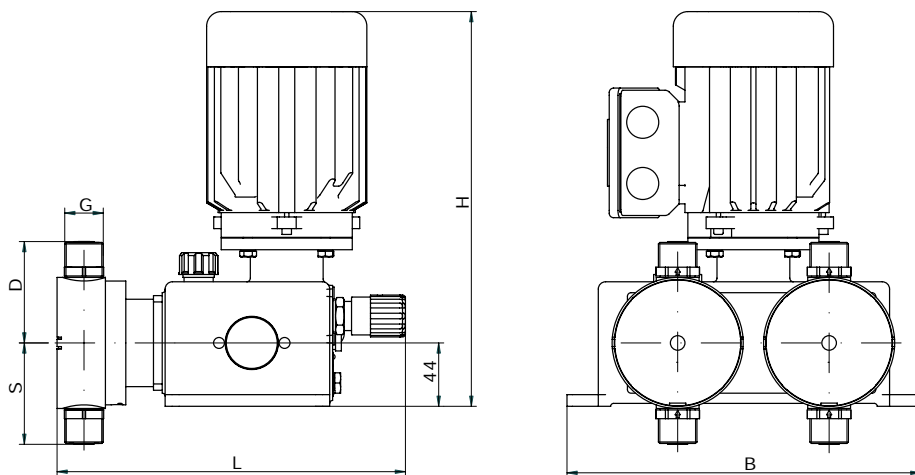

Dimensional chart

All indications in mm

Type	G	S	D	L	B	H	Weight kg
ZR409.1-18e	G 3/4	56	64	235	243	325	15
ZR409.1-27e	G 3/4	56	64	235	243	325	15
ZR409.1-50e	G 3/4	69	69	236	243	325	15.5
ZR409.1-75e	G 3/4	69	69	236	243	325	15.5
ZR409.1-90e	G 3/4	76	76	248	243	325	19
ZR409.1-115e	G 3/4	76	76	248	243	325	18
ZR409.1-150e	G 3/4	76	76	248	243	325	19
ZR409.1-190e	G 3/4	76	76	248	243	325	18

Indication of weight for Basic design acc. to order information

Order information

Basic design

ZR409.1-18e to ZR409.1-90e and ZR409.1-150e

- Pump bodies PP-FRP
- Double valves PP-FRP
- Valve balls glass
- Valve seals FPM
- Working diaphragm PTFE-faced

ZR409.1-115e and ZR409.1-190e

- Pump bodies PP-FRP
- Double valves PP-FRP
- Valve balls glass
- Valve seals FPM
- Working diaphragm EPDM





Motor:

- 200-254/346-440 V 50 Hz / 200-280/346-480 V 60 Hz threephase, IP 55, insul. cl. F

Further options and accessories

- Connection pieces see chapter 4
- Product documentation see chapter 5

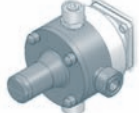
Type	Basic design	x
ZR409.1-18e	16005186	
ZR409.1-27e	16000927	
ZR409.1-50e	16002482	
ZR409.1-75e	16003838	
ZR409.1-90e	16002166	
ZR409.1-115e	16003951	
ZR409.1-150e	16004005	
ZR409.1-190e	16003460	

Options/Accessories			ZR409.1-18e ZR409.1-27e	x	ZR409.1-50e ZR409.1-75e	x	ZR409.1-90e ZR409.1-150e	x	ZR409.1-115e ZR409.1-190e	x
Pump body and valves 	PP-FRP	double valves PP-FRP	●		●		●		●	
	PVC-U	single valves PVC-U	▲		▲		▲		▲	
	PVDF	double valves PVDF-FRP	▲		-		-		-	
	PVDF-FRP	double valves PVDF-FRP	▲		▲		▲		▲	
	1.4571/1.4581	double valves 1.4571/1.4581	▲		▲		▲		▲	
Valve balls 	Glass	single valves	○		○		○		○	
		double valves	●		●		●		●	
	1.4401	single valves	○		○		○		○	
		double valves	○		○		○		○	
	PTFE	single valves	▲		▲		▲		▲	
		double valves	▲		▲		▲		▲	
Valve sealings 	FPM	double valves	●		●		●		●	
	EPDM	single/double valves	○		○		○		○	
	FEP-covered	single valves	▲		▲		▲		▲	
		double valves	▲		▲		▲		▲	
Intergrated relief valve 	with PTFE-faced diaphragm, connection seal FPM or EPDM at pump body made of:									
	PVC-U		▲		▲		▲		▲	
	PVDF		⊙		⊙		⊙		⊙	
	PP		▲		▲		▲		▲	
	1.4571		▲		▲		▲		▲	
	Connection seals FEP-covered			▲		▲		▲		▲
Double diaphragm design 	with intermediate diaphragm made of:									
	CSM			▲		▲		▲		▲
	PTFE			▲		▲		▲		▲

● = Basic design

▲ = with add. price

⊙ = on request

○ = without add. price

- = not available

Art.-Nr. = available in basic design/accessories

Diaphragm-multi-headed pumps

Flow capacity 2 x 18 l/h ... 2 x 190 l/h

Admissible counterpressure up to 10 bar



ZR409.1

Order information

Basic design

ZR409.1-18e to ZR409.1-90e and ZR409.1-150e

- Pump bodies PP-FRP
- Double valves PP-FRP
- Valve balls glass
- Valve seals FPM
- Working diaphragm PTFE-faced

ZR409.1-115e and ZR409.1-190e

- Pump bodies PP-FRP
- Double valves PP-FRP
- Valve balls glass
- Valve seals FPM
- Working diaphragm EPDM



Motor:

- 200-254/346-440 V 50 Hz / 200-280/346-480 V 60 Hz threephase, IP 55, insul. cl. F

Further options and accessories

- Connection pieces see chapter 4
- Product documentation see chapter 5

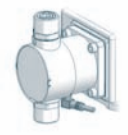
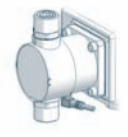
Type	Basic design	x
ZR409.1-18e	16005186	
ZR409.1-27e	16000927	
ZR409.1-50e	16002482	
ZR409.1-75e	16003838	
ZR409.1-90e	16002166	
ZR409.1-115e	16003951	
ZR409.1-150e	16004005	
ZR409.1-190e	16003460	

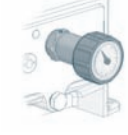
Options/Accessories		ZR409.1-18e ZR409.1-27e x	ZR409.1-50e ZR409.1-75e x	ZR409.1-90e ZR409.1-150e x	ZR409.1-115e ZR409.1-190e x	
Working diaphragms 	PTFE-faced	●	●	●	–	
	EPDM	–	–	–	●	
	FPM	▲	▲	▲	▲	
Diaphragm rupture monitoring 	Diaphragm rupture electrode conductive, mounted to pump					
	MBE-02 for single diaphragm pump MBE-03 for double diaphragm pump	▲	▲	▲	▲	
Diaphragm rupture monitoring 	ATEX-Design (Type examination, only for Double diaphragm design) Diaphragm rupture monitoring, conductive, mounted on the pump					
	MBE-03 incl. Connection cable for Diaphragm rupture monitoring blue for EExia-circuit (5m)	▲	▲	▲	▲	
	Buffer fluid glycol-glycerine-mixture 1:25 for media with conductivity $\leq 5 \mu\text{S/cm}$	▲	▲	▲	▲	
Diaphragm rupture monitoring 	Electrode relay, control cabinet assembly					
	ER-104/C	aux. energy 230 V AC	90022994	90022994	90022994	90022994
		aux. energy 24 V DC	90022945	90022945	90022945	90022945
ER-142	aux. energy 230 V AC II(1)G [EExia] IIC acc. to ATEX 95	90200363	90200363	90200363	90200363	
Stroke length adjustment 	with position indicator	▲	▲	▲	▲	
● = Basic design ▲ = with add. price ○ = on request ○ = without add. price – = not available Art.-Nr. = available in basic design/accessories						

Order information

Basic design

ZR409.1-18e to ZR409.1-90e and ZR409.1-150e

- Pump bodies PP-FRP
- Double valves PP-FRP
- Valve balls glass
- Valve seals FPM
- Working diaphragm PTFE-faced

ZR409.1-115e and ZR409.1-190e

- Pump bodies PP-FRP
- Double valves PP-FRP
- Valve balls glass
- Valve seals FPM
- Working diaphragm EPDM

Motor:

- 200-254/346-440 V 50 Hz / 200-280/346-480 V 60 Hz threephase, IP 55, insul. cl. F

Further options and accessories

- Connection pieces see chapter 4
- Product documentation see chapter 5

Type	Basic design	x
ZR409.1-18e	16005186	
ZR409.1-27e	16000927	
ZR409.1-50e	16002482	
ZR409.1-75e	16003838	
ZR409.1-90e	16002166	
ZR409.1-115e	16003951	
ZR409.1-150e	16004005	
ZR409.1-190e	16003460	

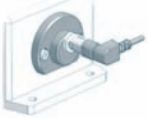
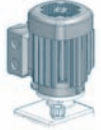
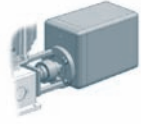
Options/Accessories		ZR409.1-18e ZR409.1-27e x	ZR409.1-50e ZR409.1-75e x	ZR409.1-90e ZR409.1-150e x	ZR409.1-115e ZR409.1-190e x
Stroke frequency monitoring 	Inductive contact				
	10-60 V DC, three-wire, PNP	▲	▲	▲	▲
Drive motor 	Namur execution, II2G EEExia IICT6 acc. to ATEX95	▲	▲	▲	▲
	Special voltage	▲	▲	▲	▲
	Enclosure IP 65	▲	▲	▲	▲
	Protective roof for the fan of the drive	▲	▲	▲	▲
	Integrated posistor (3 pcs.) insul. cl. F	▲	▲	▲	▲
	VIK-design	▲	▲	▲	▲
	II2G EEExe IIT4 (acc. to ATEX95)	▲	▲	▲	▲
	II2G EEExde IICT4 (acc. to ATEX95)	▲	▲	▲	▲
	Single phase AC 230V with capacitor	▲	▲	▲	▲
	Driver for converter operation incl. posistor, 5-100 Hz	▲	▲	▲	▲
Driver for converter operation II2G EEExde IICT4, 5-100 Hz gem. ATEX 95, incl. integrated posistor	▲	▲	▲	▲	
Stroke length adjustment electrical 	Actuator N C1-BA 230 V, +/- 10%, 50/60 Hz, 128s/10 U, 1,5 Nm incl. mounting plate for actuator	⓪	⓪	⓪	⓪
	Electronic positioning controller PMR3 input signal 0/4-20 mA incl. feedback signal 0/4-20 mA (only in N C1-BA integrated)	⓪	⓪	⓪	⓪
● = Basic design ▲ = with add. price ⓪ = on request ○ = without add. price - = not available Art.-Nr. = available in basic design/accessories					

Order information

Basic design

ZR409.1-18e to ZR409.1-90e and ZR409.1-150e

- Pump bodies PP-FRP
- Double valves PP-FRP
- Valve balls glass
- Valve seals FPM
- Working diaphragm PTFE-faced

ZR409.1-115e and ZR409.1-190e

- Pump bodies PP-FRP
- Double valves PP-FRP
- Valve balls glass
- Valve seals FPM
- Working diaphragm EPDM

Motor:

- 200-254/346-440 V 50 Hz / 200-280/346-480 V 60 Hz three-phase, IP 55, insul. cl. F

Further options and accessories

- Connection pieces see chapter 4
- Product documentation see chapter 5

Type	Basic design	x
ZR409.1-18e	16005186	
ZR409.1-27e	16000927	
ZR409.1-50e	16002482	
ZR409.1-75e	16003838	
ZR409.1-90e	16002166	
ZR409.1-115e	16003951	
ZR409.1-150e	16004005	
ZR409.1-190e	16003460	

Options/Accessories

ZR409.1-18e ZR409.1-27e x	ZR409.1-50e ZR409.1-75e x	ZR409.1-90e ZR409.1-150e x	ZR409.1-115e ZR409.1-190e x
------------------------------	------------------------------	-------------------------------	--------------------------------

Stroke frequency adjustment electrical

Frequency converter series 8200 Motec mounted-on, input 4-20mA



Single-phase 230 V, 50/60 Hz	0.25 kW	▲	▲	–	▲
	0.37 kW	–	–	▲	–
Three-phase 320-550 V, +/- 0%, 50/60 Hz	0.55 kW	▲	▲	▲	▲
Switch-potentiometer for manual stroke frequency adjustment and to switch on the pump motor (External control of the frequency converter with mounted switch potentiometer unit is not possible)		▲	▲	▲	▲
Service module hand terminal and keypad incl. 2,5m connection cable		▲	▲	▲	▲

Stroke frequency adjustment electrical

Frequency converter series 8200 Vector input 4-20mA, incl. Keypad (for integration into control cabinet)



Single-phase 230 V, 50/60 Hz	0.37 kW	–	–	90017522	–
	0.25 kW	90017521	90017521	–	90017521
Three-phase 320-550 V, +/- 0%, 50/60 Hz	0.55 kW	90017526	90017526	90017526	90017526

Console

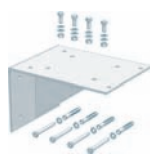

for wall mounting incl. fixing screws	1.4301	Ⓞ	Ⓞ	Ⓞ	Ⓞ
	PP	Ⓞ	Ⓞ	Ⓞ	Ⓞ

● = Basic design ▲ = with add. price Ⓞ = on request ○ = without add. price – = not available Art.-Nr. = available in basic design/accessories

Fittings for suction side of dosing pumps		ZR409.1-18e ZR409.1-27e		ZR409.1-50e		ZR409.1-75e ZR409.1-90e		ZR409.1-115e up to ZR409.1-190e	
		Type	p.	Type	p.	Type	p.	Type	p.
Suction lance	with level switch 1-stage	SL-11.1	3.36	SL-02	3.34	SL-02	3.34	SL-02	3.34
		S-03	3.38	S-03	3.38	S-03	3.38	S-03	3.38
	with level switch 2-stage	SL-12.1	3.36	SL-02	3.34	SL-02	3.34	SL-02	3.34
		S-01	3.42	S-01	3.42	S-01	3.42	S-01	3.42
Suction aid / Siphon Vessel	transparent PVC-U	770.2	3.74	770.2	3.74	770.2	3.74	770.2	3.74
Calibration Pot	PVC-U	792.1	3.76	792.1	3.76	793.1	3.76	794.1	3.76
Foot valve	PVC-U	731	3.78	731	3.78	731	3.78	731	3.78
	PP-FRP / PVDF-FRP	781.1	3.82	781.1	3.82	781.1	3.82	781.1	3.82
	1.4571	731	3.78	731	3.78	731	3.78	731	3.78
Line strainer	PVC-U	751.1	3.84	751.1	3.84	751.1	3.84	751.1	3.84
	PVC-U / PP / PVDF	752.1	3.84	752.1	3.84	752.1	3.84	752.1	3.84
	1.4408	752	3.86	752	3.86	752	3.86	752	3.86
Float valve	PVC-U	871	3.88	871	3.88	871	3.88	871	3.88
Pulsation damper without separating diaphragm	PVC-U / PP	702.1	3.14	702.1	3.14	702.1	3.14	702.1	3.14
	1.4571	802.1	3.18	802.1	3.18	802.1	3.18	802.1	3.18
Fittings for pressure side of dosing pumps		ZR409.1-18e ZR409.1-27e		ZR409.1-50e		ZR409.1-75e ZR409.1-90e		ZR409.1-115e up to ZR409.1-190e	
		Type	p.	Type	p.	Type	p.	Type	p.
Diaphragm-type relief valve	for suspension	620.10	3.4	620.10	3.4	622.10	3.4	622.10	3.4
		⊗		⊗		622.S	3.6	622.S	3.6
Diaphragm-type pressure keeping valve		620.D	3.8	620.D	3.8	622.D	3.8	622.D	3.8
Multi-function valve	4 bar opening pressure	MFV 05004	3.10	MFV 05004	3.10	–		–	
	6 bar opening pressure	MFV 05006	3.10	MFV 05006	3.10	–		–	
	10 bar opening pressure	MFV 05010	3.10	MFV 05010	3.10	–		–	
Pulsation damper without separating diaphragm	PVC-U / PP	702.1	3.14	702.1	3.14	702.1	3.14	702.1	3.14
	1.4571	802.1	3.18	802.1	3.18	802.1	3.18	802.1	3.18
Diaphragm-pulsation damper with PTFE/PTFE-faced diaphragm	PVC-U / PP / PVDF	720.1	3.24	721.2	3.24	722.1	3.24	722.1	3.24
	1.4571	721.1	3.28	721.1	3.28	722.1	3.28	722.1	3.28
Diaphragm-pulsation damper with Elastomer-diaphragm	1.4571	810.1- 0,16/180	3.30	810.1- 0,16/160	3.30	810.1- 0,32/160	3.30	810.1- 0,32/160	3.30
Check valve	PVC-U	661.2	3.48	661.2	3.48	661.2	3.48	661.2	3.48
	PP-FRP / PVDF-FRP	661.2	3.48	661.2	3.48	661.2	3.48	661.2	3.48
	1.4571	661.2	3.48	661.2	3.48	661.2	3.48	661.2	3.48
Dosing valve	PVC-U	691.1	3.54	691.1	3.54	691.1	3.54	691.1	3.54
	PVC-U / PP / PVDF	681.1	3.58	681.1	3.58	681.1	3.58	681.1	3.58
	PP-FRP / PVDF-FRP	691.1	3.54	691.1	3.54	691.1	3.54	691.1	3.54
	1.4571	691.1	3.54	691.1	3.54	691.1	3.54	691.1	3.54
Injection fitting	PVC-U / PP / PVDF	8061.1	3.60	8061.1	3.60	8061.1	3.60	8061.1	3.60

⊗ = on request – = not available

The above allocation considers the fittings which have to be used at least regarding their nominal width in order to ensure the safe and trouble-free operation of the respective pumps when feeding liquids which are resembling to water.

Absolutely note the max. admissible operating pressure of the fittings.

The use of fittings of a bigger nominal width is unproblematically possible in most cases.

When choosing the fittings note the installation instructions for dosing pumps or confer with s e r a.

Diaphragm-multi-headed pumps

Flow capacity 3 x 18 l/h ... 3 x 190 l/h

Admissible counterpressure up to 10 bar



DR409.1



DR409.1 in survey

- Compact design
- Safe to run dry
- Leakage-free
- Low maintenance
- User-friendly
- High quality materials
- High dosing accuracy
- Integratable into automatic processes
- 3 Manual stroke length adjustment
- Robust metallic stroke mechanism housing
- 3 Dosing heads - 1 drive

Infobox

- Order information [Page 2.85](#)
- Options/accessories [Page 2.85](#)
- fittings-allocation [Page 2.88](#)
- connecting pieces [Chapter 4](#)
- resistance chart [Chapter 5](#)
- installation examples [Chapter 5](#)

Technical data

Type	Nominal capacity		Nominal stroke frequency		Admissible counter pressure	Max. suction height	Inlet/ Outlet nominal width	Max. stroke length	Motor output
	l/h		1/min						
	50 Hz	60 Hz	50 Hz	60 Hz					
DR409.1-18e	3 x 0 - 18	3 x 0 - 21.5	100	120	10	3	10	6	0.18
DR409.1-27e	3 x 0 - 27	3 x 0 - 27	160	160	10	3	10	6	0.18
DR409.1-50e	3 x 0 - 50	3 x 0 - 60	100	120	10	3	10	8	0.18
DR409.1-75e	3 x 0 - 75	3 x 0 - 75	160	160	10	3	15	8	0.18
DR409.1-90e	3 x 0 - 90	3 x 0 - 108	100	120	8	3	15	10	0.37
DR409.1-115e	3 x 0 - 115	3 x 0 - 138	100	120	4	3	15	10	0.18
DR409.1-150e	3 x 0 - 150	3 x 0 - 150	160	160	8	3	15	10	0.37
DR409.1-190e	3 x 0 - 190	3 x 0 - 190	160	160	4	3	15	10	0.18

e in type designation means: pump with single diaphragm

Dimensional drawing

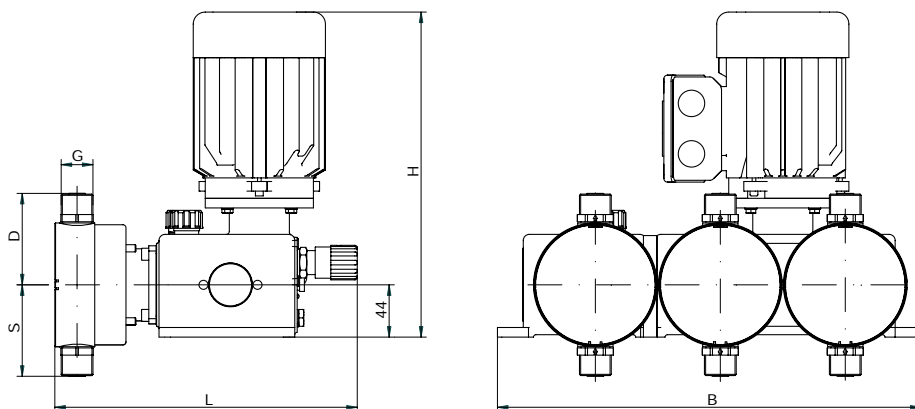

Dimensional chart

All indications in mm

Type	G	S	D	L	B	H	Weight kg
DR409.1-18e	G 3/4	56	64	235	353	325	22
DR409.1-27e	G 3/4	56	64	235	353	325	22
DR409.1-50e	G 3/4	69	69	236	353	325	24
DR409.1-75e	G 3/4	69	69	236	353	325	24
DR409.1-90e	G 3/4	76	76	248	353	325	29
DR409.1-115e	G 3/4	76	76	248	353	325	26.5
DR409.1-150e	G 3/4	76	76	248	353	325	29
DR409.1-190e	G 3/4	76	76	248	353	325	26.5

Indication of weight for Basic design acc. to order information

Order information

Basic design

DR409.1-18e to DR409.1-90e and

DR409.1-150e:

- Pump bodies PP-FRP
- Double valves PP-FRP
- Valve balls glass
- Valve seals FPM
- Working diaphragms PTFE-faced

DR409.1-115e and DR409.1-190e:

- Pump bodies PP-FRP
- Double valves PP-FRP
- Valve balls glass
- Valve seals FPM
- Working diaphragms EPDM





Motor:

- 200-254/346-440 V 50 Hz / 200-280/346-480 V 60 Hz threephase, IP 55, insul. cl. F

Further options and accessories:

- Connection pieces see chapter 4
- Product documentation see chapter 5

Type	Basic design	x
DR409.1-18e	16002415	
DR409.1-27e	16003952	
DR409.1-50e	16001002	
DR409.1-75e	16003957	
DR409.1-90e	16004112	
DR409.1-115e	16004006	
DR409.1-150e	16004007	
DR409.1-190e	16003842	

Options/Accessories			DR409.1-18e DR409.1-27e x	DR409.1-50e DR409.1-75e x	DR409.1-90e DR409.1-150e x	DR409.1-115e DR409.1-190e x
	PP-FRP	double valves PP-FRP	●	●	●	●
	PVC-U	single valves PVC-U	▲	▲	▲	▲
	PVDF-FRP	double valves PVDF-FRP	▲	▲	▲	▲
	PVDF	double valves PVDF-FRP	▲	–	–	–
	1.4571	double valves 1.4571/1.4581	▲	▲	▲	▲
	Glass	single valves	○	○	○	○
		double valves	●	●	●	●
	1.4401	single valves	○	○	○	○
		double valves	○	○	○	○
	PTFE	single valves	▲	▲	▲	▲
double valves		▲	▲	▲	▲	
	FPM	single valves	○	○	○	○
		double valves	●	●	●	●
	EPDM	single/double valves	○	○	○	○
		single valves	▲	▲	▲	▲
	double valves	▲	▲	▲	▲	
	with intermediate diaphragm made of:					
	CSM		▲	▲	▲	▲
	PTFE		▲	▲	▲	▲
	PTFE-kasch.		●	●	●	–
	EPDM		–	–	–	●
	FPM		▲	▲	▲	▲

● = Basic design ▲ = with add. price ○ = on request – = not available ○ = without add. price Art.-Nr. = available in basic design/accessories

Diaphragm-multi-headed pumps

Flow capacity 3 x 18 l/h ... 3 x 190 l/h

Admissible counterpressure up to 10 bar



DR409.1

Order information

Basic design

DR409.1-18e to DR409.1-90e and DR409.1-150e:

- Pump bodies PP-FRP
- Double valves PP-FRP
- Valve balls glass
- Valve seals FPM
- Working diaphragms PTFE-faced

DR409.1-115e and DR409.1-190e:

- Pump bodies PP-FRP
- Double valves PP-FRP
- Valve balls glass
- Valve seals FPM
- Working diaphragms EPDM





Motor:

- 200-254/346-440 V 50 Hz / 200-280/346-480 V 60 Hz three-phase, IP 55, insul. cl. F

Further options and accessories:

- Connection pieces see chapter 4
- Product documentation see chapter 5

Type	Basic design	x
DR409.1-18e	16002415	
DR409.1-27e	16003952	
DR409.1-50e	16001002	
DR409.1-75e	16003957	
DR409.1-90e	16004112	
DR409.1-115e	16004006	
DR409.1-150e	16004007	
DR409.1-190e	16003842	

Options/Accessories		DR409.1-18e DR409.1-27e x	DR409.1-50e DR409.1-75e x	DR409.1-90e DR409.1-150e x	DR409.1-115e DR409.1-190e x																	
Diaphragm rupture monitoring 	Diaphragm rupture electrode conductive, mounted to pump																					
	<table border="0"> <tr> <td>MBE-02</td> <td>for single diaphragm pump</td> <td>▲</td> <td>▲</td> <td>▲</td> <td>▲</td> </tr> <tr> <td>MBE-03</td> <td>for double diaphragm pump</td> <td>▲</td> <td>▲</td> <td>▲</td> <td>▲</td> </tr> </table>	MBE-02	for single diaphragm pump	▲	▲	▲	▲	MBE-03	for double diaphragm pump	▲	▲	▲	▲									
MBE-02	for single diaphragm pump	▲	▲	▲	▲																	
MBE-03	for double diaphragm pump	▲	▲	▲	▲																	
Diaphragm rupture monitoring 	ATEX-Design (Type examination, only for Double diaphragm design) Diaphragm rupture monitoring, konduktiv, mounted on the pump																					
	<table border="0"> <tr> <td>MBE-03 incl. Connection cable for Diaphragm rupture monitoring blue for EExia-circuit (5m)</td> <td></td> <td>▲</td> <td>▲</td> <td>▲</td> <td>▲</td> </tr> <tr> <td>Buffer fluid glycol-glycerine-mixture 1:25 for media with conductivity <math>\leq 5\mu\text{S}/\text{cm}</math></td> <td></td> <td>▲</td> <td>▲</td> <td>▲</td> <td>▲</td> </tr> </table>	MBE-03 incl. Connection cable for Diaphragm rupture monitoring blue for EExia-circuit (5m)		▲	▲	▲	▲	Buffer fluid glycol-glycerine-mixture 1:25 for media with conductivity $\leq 5\mu\text{S}/\text{cm}$		▲	▲	▲	▲									
MBE-03 incl. Connection cable for Diaphragm rupture monitoring blue for EExia-circuit (5m)		▲	▲	▲	▲																	
Buffer fluid glycol-glycerine-mixture 1:25 for media with conductivity $\leq 5\mu\text{S}/\text{cm}$		▲	▲	▲	▲																	
Diaphragm rupture monitoring 	Electrode relay, control cabinet assembly																					
	<table border="0"> <tr> <td>ER-104/C</td> <td>aux. energy 230 V AC</td> <td>90022994</td> <td>90022994</td> <td>90022994</td> <td>90022994</td> </tr> <tr> <td></td> <td>aux. energy 24 V DC</td> <td>90022945</td> <td>90022945</td> <td>90022945</td> <td>90022945</td> </tr> <tr> <td>ER-142</td> <td>aux. energy 230 V AC II(1)G [EExia] IIC acc. to ATEX 95</td> <td>90200363</td> <td>90200363</td> <td>90200363</td> <td>90200363</td> </tr> </table>	ER-104/C	aux. energy 230 V AC	90022994	90022994	90022994	90022994		aux. energy 24 V DC	90022945	90022945	90022945	90022945	ER-142	aux. energy 230 V AC II(1)G [EExia] IIC acc. to ATEX 95	90200363	90200363	90200363	90200363			
ER-104/C	aux. energy 230 V AC	90022994	90022994	90022994	90022994																	
	aux. energy 24 V DC	90022945	90022945	90022945	90022945																	
ER-142	aux. energy 230 V AC II(1)G [EExia] IIC acc. to ATEX 95	90200363	90200363	90200363	90200363																	
Stroke length adjustment 	with position indicator	▲	▲	▲	▲																	
Stroke frequency monitoring 	Inductive contact																					
	<table border="0"> <tr> <td>10-60 V DC, three-wire, PNP</td> <td></td> <td>▲</td> <td>▲</td> <td>▲</td> <td>▲</td> </tr> <tr> <td>Namur execution, II2G EExia IIC T6 acc. to ATEX95</td> <td></td> <td>▲</td> <td>▲</td> <td>▲</td> <td>▲</td> </tr> </table>	10-60 V DC, three-wire, PNP		▲	▲	▲	▲	Namur execution, II2G EExia IIC T6 acc. to ATEX95		▲	▲	▲	▲									
10-60 V DC, three-wire, PNP		▲	▲	▲	▲																	
Namur execution, II2G EExia IIC T6 acc. to ATEX95		▲	▲	▲	▲																	

● = Basic design ▲ = with add. price ⊗ = on request – = not available ○ = without add. price Art.-Nr. = available in basic design/accessories

Order information

Basic design

DR409.1-18e to DR409.1-90e and DR409.1-150e:

- Pump bodies PP-FRP
- Double valves PP-FRP
- Valve balls glass
- Valve seals FPM
- Working diaphragms PTFE-faced

DR409.1-115e and DR409.1-190e:

- Pump bodies PP-FRP
- Double valves PP-FRP
- Valve balls glass
- Valve seals FPM
- Working diaphragms EPDM



Motor:

- 200-254/346-440 V 50 Hz / 200-280/346-480 V 60 Hz threephase, IP 55, insul. cl. F

Further options and accessories:

- Connection pieces see chapter 4
- Product documentation see chapter 5

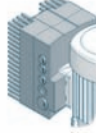
Type	Basic design	x
DR409.1-18e	16002415	
DR409.1-27e	16003952	
DR409.1-50e	16001002	
DR409.1-75e	16003957	
DR409.1-90e	16004112	
DR409.1-115e	16004006	
DR409.1-150e	16004007	
DR409.1-190e	16003842	

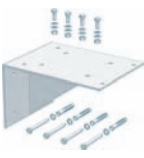
Options/Accessories		DR409.1-18e DR409.1-27e x	DR409.1-50e DR409.1-75e x	DR409.1-90e DR409.1-150e x	DR409.1-115e DR409.1-190e x	
Drive motor 	Special voltage	▲	▲	▲	▲	
	Enclosure IP 65	▲	▲	▲	▲	
	Protective roof for the fan of the drive	▲	▲	▲	▲	
	Integrated posistor (3 pcs.) insul. cl. F	▲	▲	▲	▲	
	VIK-design	▲	▲	▲	▲	
	I12G EEExe IIT4 (acc. to ATEX95)	▲	▲	▲	▲	
	I12G EEExde IICT4 (acc. to ATEX95)	▲	▲	▲	▲	
	Single phase AC 230V with capacitor	▲	▲	▲	▲	
	Driver for converter operation incl. integrated posistor, 5-50/60Hz	▲	▲	▲	▲	
	Driver for converter operation I12G EEExde IICT4, 5-50/60 Hz gem. ATEX 95, incl. integrated posistor	▲	▲	▲	▲	
Stroke frequency adjustment electrical 	Frequency converter series 8200 Motec mounted-on, input 4-20mA					
	Single-phase 230 V, 50/60 Hz	0.25 kW	▲	▲	–	▲
		0.37 kW	–	–	▲	–
	Three-phase 320-550 V, +/- 0%, 50/60 Hz	0.55 kW	▲	▲	▲	▲
		Switch-potentiometer for manual stroke frequency adjustment and to switch on the pump motor (External control of the frequency converter with mounted switch potentiometer unit is not possible)		▲	▲	▲
	Service module hand terminal and keypad incl. 2,5m connection cable		▲	▲	▲	▲
Stroke frequency adjustment electrical 	Frequency converter series 8200 Vector input 4-20mA, incl. Keypad (for integration into control cabinet)					
	Single-phase 230 V, 50/60 Hz	0.25 kW	90017521	90017521	–	90017521
		0.37 kW	–	–	90017522	–
	Three-phase 320-550 V, +/- 0%, 50/60 Hz	0.55 kW	90017526	90017526	90017526	90017526
Console 	1.4301	⊙	⊙	⊙	⊙	
	for wall mounting incl. fixing screws PP		⊙	⊙	⊙	⊙

● = Basic design ▲ = with add. price ⊙ = on request – = not available ○ = without add. price Art.-Nr. = available in basic design/accessories

Fittings for suction side of dosing pumps			DR409.1-18e DR409.1-27e		DR409.1-50e		DR409.1-75e DR409.1-90e		DR409.1-115e up to DR409.1-190e	
			Type	p.	Type	p.	Type	p.	Type	p.
Suction lance	with level switch 1-stage	SL-11.1	3.36	SL-02	3.34	SL-02	3.34	SL-02	3.34	
		S-03	3.38	S-03	3.38	S-03	3.38	S-03	3.38	
	with level switch 2-stage	SL-12.1	3.36	SL-02	3.34	SL-02	3.34	SL-02	3.34	
		S-01	3.42	S-01	3.42	S-01	3.42	S-01	3.42	
Suction aid / Siphon Vessel	transparent PVC-U	770.2	3.74	770.2	3.74	770.2	3.74	770.2	3.74	
Calibration Pot	PVC-U	792.1	3.76	792.1	3.76	793.1	3.76	794.1	3.76	
Foot valve	PVC-U	731	3.78	731	3.78	731	3.78	731	3.78	
	PP-FRP / PVDF-FRP	781.1	3.82	781.1	3.82	781.1	3.82	781.1	3.82	
	1.4571	731	3.78	731	3.78	731	3.78	731	3.78	
Line strainer	PVC-U	751.1	3.84	751.1	3.84	751.1	3.84	751.1	3.84	
	PVC-U / PP / PVDF	752.1	3.84	752.1	3.84	752.1	3.84	752.1	3.84	
	1.4408	752	3.86	752	3.86	752	3.86	752	3.86	
Float valve	PVC-U	871	3.88	871	3.88	871	3.88	871	3.88	
Pulsation damper without separating diaphragm	PVC-U / PP	702.1	3.14	702.1	3.14	702.1	3.14	702.1	3.14	
	1.4571	802.1	3.18	802.1	3.18	802.1	3.18	802.1	3.18	
Fittings for pressure side of dosing pumps			DR409.1-18e DR409.1-27e		DR409.1-50e		DR409.1-75e DR409.1-90e		DR409.1-115e up to DR409.1-190e	
			Type	p.	Type	p.	Type	p.	Type	p.
Diaphragm-type relief valve	for suspension	620.10	3.4	620.10	3.4	622.10	3.4	622.10	3.4	
		⊗		⊗		622.S	3.6	622.S	3.6	
Diaphragm-type pressure keeping valve		620.D	3.8	620.D	3.8	622.D	3.8	622.D	3.8	
Multi-function valve	4 bar opening pressure	MFV 05004	3.10	MFV 05004	3.10	–		–		
	6 bar opening pressure	MFV 05006	3.10	MFV 05006	3.10	–		–		
	10 bar opening pressure	MFV 05010	3.10	MFV 05010	3.10	–		–		
Pulsation damper without separating diaphragm	PVC-U / PP	702.1	3.14	702.1	3.14	702.1	3.14	702.1	3.14	
	1.4571	802.1	3.18	802.1	3.18	802.1	3.18	802.1	3.18	
Diaphragm-pulsation damper with PTFE/PTFE-faced diaphragm	PVC-U / PP / PVDF	720.1	3.24	721.2	3.24	722.1	3.24	722.1	3.24	
	1.4571	721.1	3.28	721.1	3.28	722.1	3.28	722.1	3.28	
Diaphragm-pulsation damper with Elastomer-diaphragm	1.4571	810.1- 0,16/180	3.30	810.1- 0,16/160	3.30	810.1- 0,32/160	3.30	810.1- 0,32/160	3.30	
Check valve	PVC-U	661.2	3.48	661.2	3.48	661.2	3.48	661.2	3.48	
	PP-FRP / PVDF-FRP	661.2	3.48	661.2	3.48	661.2	3.48	661.2	3.48	
	1.4571	661.2	3.48	661.2	3.48	661.2	3.48	661.2	3.48	
Dosing valve	PVC-U	691.1	3.54	691.1	3.54	691.1	3.54	691.1	3.54	
	PVC-U / PP / PVDF	681.1	3.58	681.1	3.58	681.1	3.58	681.1	3.58	
	PP-FRP / PVDF-FRP	691.1	3.54	691.1	3.54	691.1	3.54	691.1	3.54	
	1.4571	691.1	3.54	691.1	3.54	691.1	3.54	691.1	3.54	
Injection fitting	PVC-U / PP / PVDF	8061.1	3.60	8061.1	3.60	8061.1	3.60	8061.1	3.60	

⊗ = on request

– = not available

The above allocation considers the fittings which have to be used at least regarding their nominal width in order to ensure the safe and trouble-free operation of the respective pumps when feeding liquids which are resembling to water.

Absolutely note the max. admissible operating pressure of the fittings.

The use of fittings of a bigger nominal width is unproblematically possible in most cases.

When choosing the fittings note the installation instructions for dosing pumps or confer with s e r a.

Diaphragm-Feeding pumps

Flow capacity 450 l/h ... 1300 l/h

Admissible counterpressure up to 3 bar



ZYM409.1



ZYM409.1 in survey

- Leakage - free
- Safe if run dry
- High quality materials
- Low maintenance
- Low operating costs
- Integrateable into automatic processes
- Robust metallic stroke mechanism housing
- User friendly

Infobox

Order information	Page 2.91
Options/accessories	Page 2.91
fittings-allocation	Page 2.94
connecting pieces	Chapter 4
resistance chart	Chapter 5
installation examples	Chapter 5

Technical data

Type	Nominal capacity		Nominal stroke frequency		Admissible counter-pressure	Admissible pressure at pump inlet	Max. suction height	Inlet/ Outlet nominal width	Max. stroke length	Motor output
	l/h		1/min							
	50 Hz	60 Hz	50 Hz	60 Hz	bar	bar	mWS	DN	mm	kW
ZYM409.1-450e	450	540	100	120	3	-0.3 / 0	3	15	10	0.37
ZYM409.1-650e	650	—	134	—	3	-0.3 / 0	3	15	10	0.37
ZYM409.1-900e	900	1.080	100	120	2	-0.2 / 0	2	20	10	0.37
ZYM409.1-1300e	1.300	—	134	—	2	-0.2 / 0	2	20	10	0.37

e in type designation means: pump with single diaphragm

Dimensional drawing

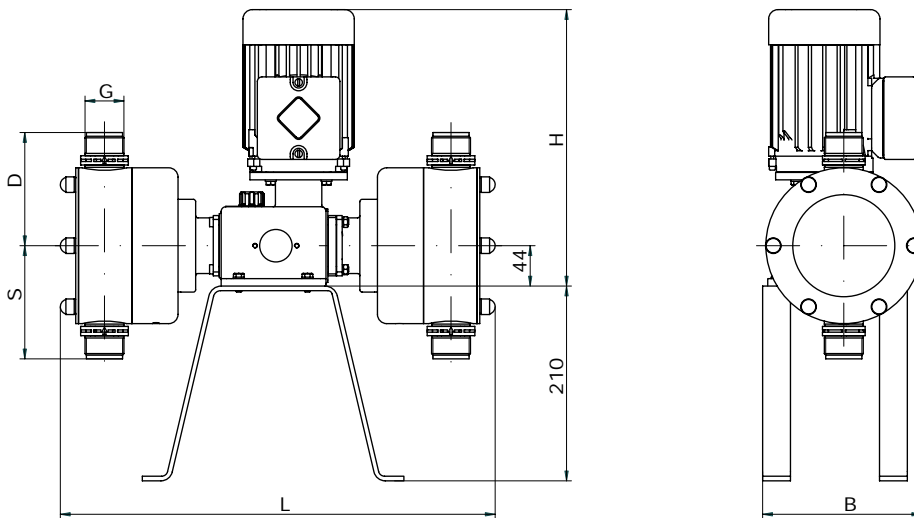

Dimensional chart

All indications in mm

Type	G	S	D	L	B	H	Weight kg
ZYM409.1-450e	G 1 1/4	122	122	457	172	510	30
ZYM409.1-650e	G 1 1/4	122	122	457	172	510	30
ZYM409.1-900e	G 1 1/4	122	122	463	172	510	30
ZYM409.1-1300e	G 1 1/4	122	122	463	172	510	30

Indication of weight for Basic design acc. to order information

Order information

Basic design

ZYM409.1:

- Pump body PP
- Single valves PP-FRP
- Valve balls glass
- Valve seals FPM
- Working diaphragms PTFE-faced
- incl. pump support







Motor:

- 200-254/346-440 V 50 Hz / 200-280/346-480 V 60 Hz threephase, IP 55, insul. cl. F

Further options and accessories:

- Connection pieces see chapter 4
- Product documentation see chapter 5

Type	Basic design	x
ZYM409.1-450e	16001456	
ZYM409.1-650e	16000894	
ZYM409.1-900e	16001801	
ZYM409.1-1300e	16002603	

Options/Accessories			ZYM409.1-450e ZYM409.1-650e	x	ZYM409.1-900e ZYM409.1-1300e	x
Pump body and valves 	PP	single valves PP-FRP	●		●	
	PVC-U	single valves PVC-U	▲		▲	
	PVDF	single valves PVDF-FRP	▲		▲	
	1.4571	single valves 1.4571/1.4581	▲		▲	
Valve balls 	Glass	single valves	●		●	
	1.4401	single valves	▲		▲	
	PTFE	single valves	▲		▲	
Valve sealings 	FPM	single valves	●		●	
	EPDM	single valves	○		○	
	FEP-covered	single valves	▲		▲	
Working diaphragms 		PTFE-faced	●		●	
Double diaphragm design 	with intermediate diaphragm made of:					
		PTFE-faced	▲		▲	
Diaphragm rupture monitoring 	Diaphragm rupture electrode conductive, mounted to pump					
	MBE-02	for single diaphragm pump	▲		▲	
	MBE-04	for double diaphragm pump	▲		▲	
● = Basic design ▲ = with add. price ○ = without add. price Art.-Nr. = available in basic design/ accessories						

Order information

Basic design

ZYM409.1:

- Pump body PP
- Single valves PP-FRP
- Valve balls glass
- Valve seals FPM
- Working diaphragms PTFE-faced
- incl. pump support





Further options and accessories:

- Connection pieces see chapter 4
- Product documentation see chapter 5

Type	Basic design	x
ZYM409.1-450e	16001456	
ZYM409.1-650e	16000894	
ZYM409.1-900e	16001801	
ZYM409.1-1300e	16002603	

Motor:

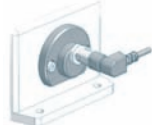
- 200-254/346-440 V 50 Hz / 200-280/346-480 V 60 Hz threephase, IP 55, insul. cl. F

Options/Accessories		ZYM409.1-450e ZYM409.1-650e	x	ZYM409.1-900e ZYM409.1-1300e	x
 Diaphragm rupture monitoring	ATEX-Design (Type examination, only for Double diaphragm design) Diaphragm rupture monitoring, konduktiv, mounted on the pump				
	MBE-04 incl. Connection cable for Diaphragm rupture monitoring blue for EExia-circuit (5m)	▲		▲	
	buffer fluid glycol-glycerine-mixture 1:25 for media with conductivity $\leq 5 \mu\text{S}/\text{cm}$	▲		▲	
 Diaphragm rupture monitoring	Electrode relay, control cabinet assembly				
	ER-104/C	aux. energy 230 V AC	90022994		90022994
		aux. energy 24 V DC	90022945		90022945
	ER-142	aux. energy 230 V AC II(1)G [EExia] IIC acc. to ATEX 95	90200363		90200363
 Stroke frequency monitoring	Inductive contact				
	10-60 V DC, three-wire, PNP	▲		▲	
	Namur execution, II2G EExia IICT6 acc. to ATEX95	▲		▲	
 Drive motor	Special voltage	▲		▲	
	Enclosure IP 65	▲		▲	
	Protective roof for the fan of the drive	▲		▲	
	Integrated posistor (3 pcs.) insul. cl. F	▲		▲	
	VIK-design	▲		▲	
	II2G EExe IIT4 (acc. to ATEX95)	▲		▲	
	II2G EExde IICT4 (acc. to ATEX95)	▲		▲	
	Single phase AC 230V with capacitor	▲		▲	
	Driver for converter operation incl. posistor, 5-100 Hz	▲		▲	
Driver for converter operation II2G EExde IICT4, 5-100 Hz gem. ATEX 95, incl. integrated posistor	▲		▲		
● = Basic design ▲ = with add. price ○ = without add. price Art.-Nr. = available in basic design/ accessories					

Order information

Basic design

ZYM409.1:

- Pump body PP
- Single valves PP-FRP
- Valve balls glass
- Valve seals FPM
- Working diaphragms PTFE-faced
- incl. pump support



Motor:

- 200-254/346-440 V 50 Hz / 200-280/346-480 V 60 Hz threephase, IP 55, insul. cl. F

Further options and accessories:

- Connection pieces see chapter 4
- Product documentation see chapter 5

Type	Basic design	x
ZYM409.1-450e	16001456	
ZYM409.1-650e	16000894	
ZYM409.1-900e	16001801	
ZYM409.1-1300e	16002603	

Options/Accessories		ZYM409.1-450e ZYM409.1-650e	x	ZYM409.1-900e ZYM409.1-1300e	x
Stroke frequency adjustment electrical 	Frequency converter series 8200 Motec mounted-on, input 4-20mA				
	Single-phase 230 V, 50/60 Hz 0.37 kW	▲		▲	
	Three-phase 320-550 V, +/- 0%, 50/60 Hz 0.55 kW	▲		▲	
	Switch-potentiometer for manual stroke frequency adjustment and to switch on the pump motor (External control of the frequency converter with mounted switch potentiometer unit is not possible)	▲		▲	
	Service module hand terminal and keypad incl. 2,5m connection cable	▲		▲	
Stroke frequency adjustment electrical 	Frequency converter series 8200 Vector input 4-20mA, incl. Keypad (for integration into control cabinet)				
	Single-phase 230 V, 50/60 Hz 0.37 kW		90017522		90017522
	Three-phase 320-550 V, +/- 0%, 50/60 Hz 0.55 kW		90017526		90017526
● = Basic design ▲ = with add. price ○ = without add. price Art.-Nr. = available in basic design/ accessories					

Fittings for suction side of dosing pumps		ZYM409.1-450e		ZYM409.1-650e		ZYM409.1-900e		ZYM409.1-1300e	
		Type	p.	Type	p.	Type	p.	Type	p.
Suction lance	with level switch 1-stage	S-04	3.40	⊗		⊗		⊗	
	without level switch	S-01	3.42	S-01	3.42	S-01	3.42	S-01	3.42
Suction aid / Siphon Vessel	transparent PVC-U	770.2	3.74	770.2	3.74	771.2	3.74	772.2	3.74
Calibration Pot	PVC-U	795.1	3.76	796.1	3.76	796.1	3.76	796.1	3.76
Foot valve	PVC-U	732.2	3.80	732.2	3.80	733.2	3.80	733.2	3.80
	PP / PVDF	732	3.78	732	3.78	733	3.78	733	3.78
	1.4571	732	3.78	732	3.78	733	3.78	733	3.78
Line strainer	PVC-U / PP / PVDF	752.1	3.84	752.1	3.84	753.1	3.84	754.1	3.84
	1.4408	752	3.86	752	3.86	753	3.86	754	3.86
Float valve	PVC-U	872	3.88	872	3.88	873	3.88	873	3.88
Pulsation damper without separating diaphragm	PVC-U / PP	702.1	3.14	702.1	3.14	703.1	3.14	703.1	3.14
	1.4571	802.1	3.18	802.1	3.18	803.1	3.18	803.1	3.18
Fittings for pressure side of dosing pumps		ZYM409.1-450e		ZYM409.1-650e		ZYM409.1-900e		ZYM409.1-1300e	
		Type	p.	Type	p.	Type	p.	Type	p.
Diaphragm-type relief valve		622.10	3.4	622.10	3.4	623.10	3.4	623.10	3.4
	for suspension	622.S	3.6	622.S	3.6	623.S	3.6	623.S	3.6
Diaphragm-type pressure keeping valve		622.D	3.8	622.D	3.8	623.D	3.8	623.D	3.8
Pulsation damper without separating diaphragm	PVC-U / PP	702.1	3.14	702.1	3.14	703.1	3.14	703.1	3.14
	1.4571	802.1	3.18	802.1	3.18	803.1	3.18	803.1	3.18
Diaphragm-pulsation damper with Elastomer-diaphragm	1.4571	713.1	3.22	713.1	3.22	713.1	3.22	713.1	3.22
Diaphragm-pulsation damper with PTFE/PTFE-faced diaphragm	PVC-U / PP / PVDF	723.1	3.28	723.1	3.28	723.1	3.28	723.1	3.28
Check valve	PP-FRP / PVDF-FRP	663.2	3.48	663.2	3.48	663.2	3.48	663.2	3.48
	1.4571	662.2	3.48	662.2	3.48	663.2	3.48	663.2	3.48
Dosing valve	PVC-U / PP / PVDF	682.1	3.58	682.1	3.58	683.1	3.58	683.1	3.58
	PP-FRP / PVDF-FRP	693.1	3.54	693.1	3.54	693.1	3.54	693.1	3.54
	1.4571	692.1	3.54	692.1	3.54	693.1	3.54	693.1	3.54
Injection fitting	PVC-U / PP / PVDF	8062.1	3.60	8062.1	3.60	8063.1	3.60	8063.1	3.60

⊗ = on request

The above allocation considers the fittings which have to be used at least regarding their nominal width in order to ensure the safe and trouble-free operation of the respective pumps when feeding liquids which are resembling to water.

Absolutely note the max. admissible operating pressure of the fittings.

The use of fittings of a bigger nominal width is unproblematically possible in most cases.

When choosing the fittings note the installation instructions for dosing pumps or confer with s e r a.

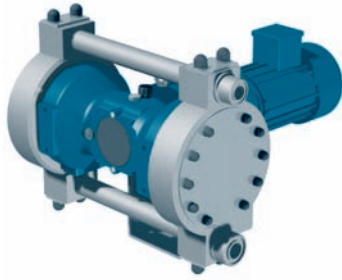

ZX411.3 im Überblick

- Leakage - free
- Safe if run dry
- High quality materials
- Low maintenance
- Low operating costs
- Integrateable in automatoc processes
- Robust metallic stroke mechanism housing
- User friendly
- Manual stroke frequency adjustment (only ZXRI-Types)

Infobox

- Order information [Page 2.97](#)
- Options/accessories [Page 2.97](#)
- fittings-allocation [Page 2.100](#)
- connecting pieces [Chapter 4](#)
- resistance chart [Chapter 5](#)
- installation examples [Chapter 5](#)

Technical data

Type	Nominal capacity		Nominal stroke frequency		Admissible counter-pressure	Admissible pressure at pump inlet	Max. suction height	Inlet nominal width	Inlet/Outlet nominal width	Max. stroke length	Motor output
	l/h		1/min								
	50 Hz	60 Hz	50 Hz	60 Hz							
ZXM411.3-2200e	2200	2640	92	110	4	-0.8 / 0	8	32	25	20	0.75
ZXRI411.3-2200e	230 - 2200	–	18-84	–	4	-0.8 / 0	8	32	25	20	0.75
ZXM411.3-2600e	2000	3120	103	123	4	-0.8 / 0	8	32	25	20	0.75
ZXRI411.3-2600e	230 - 2600	–	18-110	110	4	-0.8 / 0	8	32	25	20	0.75
ZXM411.3-3100e	3100	–	128	–	4	-0.8 / 0	8	32	25	20	0.75
ZXRI411.3-3100e	230 - 3100	–	18-123	123	4	-0.8 / 0	8	32	25	20	0.75

e in type designation means: pump with single diaphragm / RI in type designation means: pump with integrated frequency converter

Dimensional drawing

ZXM411.3-...

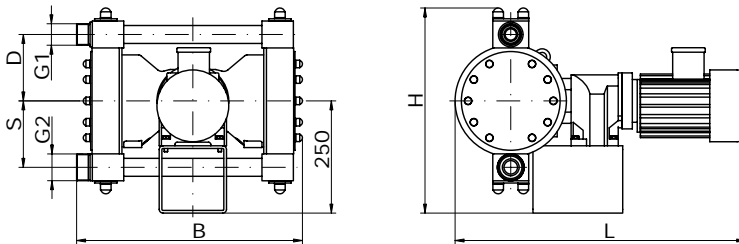

ZXRI411.3-...

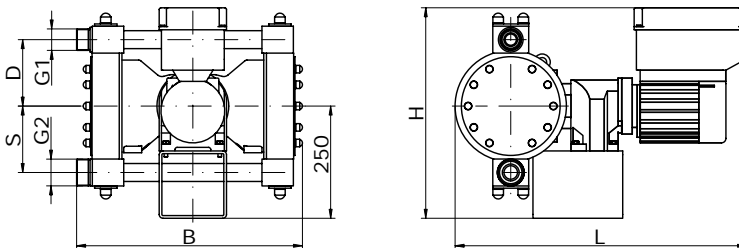

Dimensional chart

All indications in mm

Type	G2	G1	S	D	L	B	H	Weight kg
ZXM411.3-2200e	G 2	G 1 1/2	148	148	580	500	450	70
ZXRI411.3-2200e	G 2	G 1 1/2	148	148	650	500	450	80
ZXM411.3-2600e	G 2	G 1 1/2	148	148	580	500	450	70
ZXRI411.3-2600e	G 2	G 1 1/2	148	148	650	500	450	80
ZXM411.3-3100e	G 2	G 1 1/2	148	148	580	500	450	70
ZXRI411.3-3100e	G 2	G 1 1/2	148	148	650	500	450	80

Indication of weight for Basic design acc. to order information

Order information

Basic design

ZX...411.3

- Pump body PP
- Single valves PP/PP-FRP
- Valve balls glass
- Valve seals FPM
- Working diaphragms PTFE-faced





Motor:

- 230/400 V threephase, 50/60 Hz, IP 55, insul. cl. F

Further options and accessories:

- Connection pieces see chapter 4
- Product documentation see chapter 5

Type	Basic design	x
ZXM411.3-2200e	15002194	
ZXRI411.3-2200e	15002195	
ZXM411.3-2600e	15002196	
ZXRI411.3-2600e	15002197	
ZXM411.3-3100e	15002003	
ZXRI411.3-3100e	15002198	

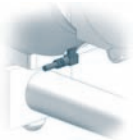
Options/Accessories			ZXM411.3-2200e ZXM411.3-2600e ZXM411.3-3100e	x	ZXRI411.3-2200e ZXRI411.3-2600e ZXRI411.3-3100e	x	
Pump body and valves 	PP	single valves PP/PP-FRP	●		●		
	PVC-U	single valves PVC/PVDF-FRP	○		○		
		single valves PVC-U	▲		▲		
	PVDF	single valves PVDF/PVDF-FRP	▲		▲		
	1.4571	single valves 1.4571/1.4581	▲		▲		
Valve balls 	Glass	single valves	●		●		
	1.4401	single valves	▲		▲		
	PTFE	single valves	▲		▲		
Valve sealings 	FPM	single valves	●		●		
	EPDM	single valves	○		○		
	FEP-covered	single valves	▲		▲		
Working diaphragms 		PTFE-faced	●		●		
Double diaphragm design 	with intermediate diaphragm made of:						
		PTFE-faced	⊗		⊗		
		PTFE	⊗		⊗		
Diaphragm rupture monitoring 	Diaphragm rupture electrode conductive, mounted to pump						
		MBE-02	for single diaphragm pump	▲		▲	
		MBE-04	for double diaphragm pump	⊗		⊗	
● = Basic design ○ = without add. price ▲ = with add. price ⊗ = on request -- = not available Art.-Nr. = available in basic design/accessories							

Order information

Basic design

ZX...411.3

- Pump body PP
- Single valves PP/PP-FRP
- Valve balls glass
- Valve seals FPM
- Working diaphragms PTFE-faced

Motor:



- 230/400 V threephase, 50/60 Hz, IP 55, insul. cl. F

Further options and accessories:

- Connection pieces see chapter 4
- Product documentation see chapter 5

Type	Basic design	x
ZXM411.3-2200e	15002194	
ZXRI411.3-2200e	15002195	
ZXM411.3-2600e	15002196	
ZXRI411.3-2600e	15002197	
ZXM411.3-3100e	15002003	
ZXRI411.3-3100e	15002198	

Options/Accessories

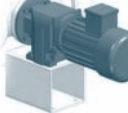
Options/Accessories		ZXM411.3-2200e ZXM411.3-2600e ZXM411.3-3100e	x	ZXRI411.3-2200e ZXRI411.3-2600e ZXRI411.3-3100e	x
Diaphragm rupture monitoring 	ATEX-Design (Type examination, only for Double diaphragm design) Diaphragm rupture monitoring, konduktiv, mounted on the pump				
	MBE-04 incl. Connection cable for Diaphragm rupture monitoring blue for EExia-circuit (5m)	⊙		⊙	
	Buffer fluid glycol-glycerine-mixture 1:25 for media with conductivity $\leq 5\mu\text{S}/\text{cm}$	⊙		⊙	
Diaphragm rupture monitoring 	Electrode relay, control cabinet assembly				
	ER-104/C	aux. energy 230 V AC	90022994		90022994
		aux. energy 24 V DC	90022945		90022945
	ER-142	aux. energy 230 V AC II(1)G [EExia] IIC acc. to ATEX 95	90200363		90200363
Stroke frequency monitoring 	Inductive contact				
	10-60 V DC, three-wire, PNP		▲		▲
	Namur execution, II2G EExia IICT6 acc. to ATEX95		▲		▲
Drive motor 	Special voltage				
			▲		⊙
	Enclosure IP 65				
			▲		⊙
	Protective roof for the fan of the drive				
			▲		⊙
	integrated posistor (3 pcs.) insul. cl. F				
			▲		●
	VIK-design				
		▲		⊙	
II2G EExe IIT3 (acc. to ATEX95)					
		▲		-	
II2G EExe IIT4 (acc. to ATEX95)					
		⊙		-	
II2G EExde IICT4 (acc. to ATEX95)					
		▲		-	
Single phase AC 230V with capacitor					
		⊙		-	
Driver for converter operation incl. integrated posistor, 5-50/60Hz					
		▲		●	
Driver for converter operation II2G EExde IICT4, 5-50/60 Hz gem. ATEX 95, incl. integrated posistor					
		⊙		-	
● = Basic design ○ = without add. price ▲ = with add. price ⊙ = on request - = not available Art.-Nr. = available in basic design/accessories					

Order information

Basic design

ZX...411.3

- Pump body PP
- Single valves PP/PP-FRP
- Valve balls glass
- Valve seals FPM
- Working diaphragms PTFE-faced

Motor:

- 230/400 V threephase, 50/60 Hz, IP 55, insul. cl. F

Further options and accessories:

- Connection pieces see chapter 4
- Product documentation see chapter 5

Type	Basic design	x
ZXM411.3-2200e	15002194	
ZXRI411.3-2200e	15002195	
ZXM411.3-2600e	15002196	
ZXRI411.3-2600e	15002197	
ZXM411.3-3100e	15002003	
ZXRI411.3-3100e	15002198	

Options/Accessories		ZXM411.3-2200e ZXM411.3-2600e ZXM411.3-3100e	x	ZXRI411.3-2200e ZXRI411.3-2600e ZXRI411.3-3100e	x
Stroke frequency adjustment electrical 	Frequency converter series 8200 Vector input 4-20mA, incl. Keypad (for integration into control cabinet)				
	Single-phase 230 V, 50/60 Hz 1.5 kW	90016865		–	
	Three-phase 320-550 V, +/- 0%, 50/60 Hz 1.5 kW	90017528		–	
● = Basic design ○ = without add. price ▲ = with add. price © = on request – = not available Art.-Nr. = available in basic design/accessories					

2

Fittings for suction side of dosing pumps		ZX411.3-2200e up to ZXRI411.3-3100e	
		Type	p.
Suction aid / Siphon Vessel	transparent PVC-U	772.2	3.74
Calibration Pot	PVC-U	797.1	3.76
Foot valve	PVC-U	735.2	3.80
	PP / PVDF	735	3.78
	1.4571	735	3.78
Line strainer	PVC-U / PP / PVDF	755.1	3.84
	1.4408	755	3.86
Float valve	PVC-U	875	3.88
Pulsation damper without separating diaphragm	PVC-U / PP	706.1	3.14
	1.4571	804.1	3.18
Fittings for pressure side of dosing pumps		ZX411.3-2200e up to ZXRI411.3-3100e	
		Type	p.
Diaphragm-type relief valve		624.10	3.4
	for Suspension	Ⓞ	
Diaphragm-type pressure keeping valve		624.D	3.8
Pulsation damper without separating diaphragm	PVC-U / PP	706.1	3.14
	1.4571	804.1	3.18
Diaphragm-pulsation damper with Elastomer-diaphragm	PVC-U / PP / PVDF	713.1	3.20
	1.4571	713.1	3.22
Dosing valve	PVC-U / PP / PVDF	684.1	3.58

Ⓞ = on request

The above allocation considers the fittings which have to be used at least regarding their nominal width in order to ensure the safe and trouble-free operation of the respective pumps when feeding liquids which are resembling to water.

Absolutely note the max. admissible operating pressure of the fittings.

The use of fittings of a bigger nominal width is unproblematically possible in most cases.

When choosing the fittings note the installation instructions for dosing pumps or confer with s e r a.

Piston diaphragm pumps

Flow capacity 8,5 l/h ... 180 l/h

Admissible counterpressure up to 50 bar



R409.1-...KM



409.1-...KM in survey

- Compact design
- Highest dosing accuracy
- Safe to run dry
- High quality materials
- Leakage-free
- Low-maintenance
- User-friendly
- Integrateable in automatic processes
- Manual stroke adjustment
- Robust metallic stroke mechanism housing

Infobox

- Order information [Page 2.103](#)
- Options/accessories [Page 2.103](#)
- fittings-allocation [Page 2.107](#)
- connecting pieces [Chapter 4](#)
- resistance chart [Chapter 5](#)
- installation examples [Chapter 5](#)

Technical data

Type	Nominal capacity		Nominal stroke frequency		Admissible counter-pressure	Admissible pressure at pump inlet	max. suction height	Inlet/Outlet nominal width	Max. stroke length	Motor output
	l/h		1/min							
	50 Hz	60 Hz	50 Hz	60 Hz						
R409.1-8,5KM/14	0 - 8.5	0 - 10	100	120	50	-0.2 / 0	2	10	10	0.18
R409.1-11KM/14	0 - 11	0 - 13	134	160	50	-0.2 / 0	2	10	10	0.18
R409.1-17KM/20	0 - 17	0 - 20	100	120	50	-0.2 / 0	2	10	10	0.37
R409.1-23KM/20	0 - 23	0 - 27	134	160	50	-0.2 / 0	2	10	10	0.37
R409.1-34KM/28	0 - 34	0 - 40	100	120	35	-0.2 / 0	2	10	10	0.37
R409.1-45KM/28	0 - 45	0 - 54	134	160	35	-0.2 / 0	2	10	10	0.37
R409.1-68KM/40	0 - 68	0 - 80	100	120	20	-0.2 / 0	2	10	10	0.37
R409.1-90KM/40	0 - 90	0 - 108	134	160	20	-0.2 / 0	2	15	10	0.37
R409.1-135KM/56	0 - 135	0 - 160	100	120	10	-0.2 / 0	2	15	10	0.37
R409.1-180KM/56	0 - 180	-	134	-	10	-0.2 / 0	2	15	10	0.37

Note: The admissible counterpressure is 10 bar when plastic pump bodies are used.

Dimensional drawing

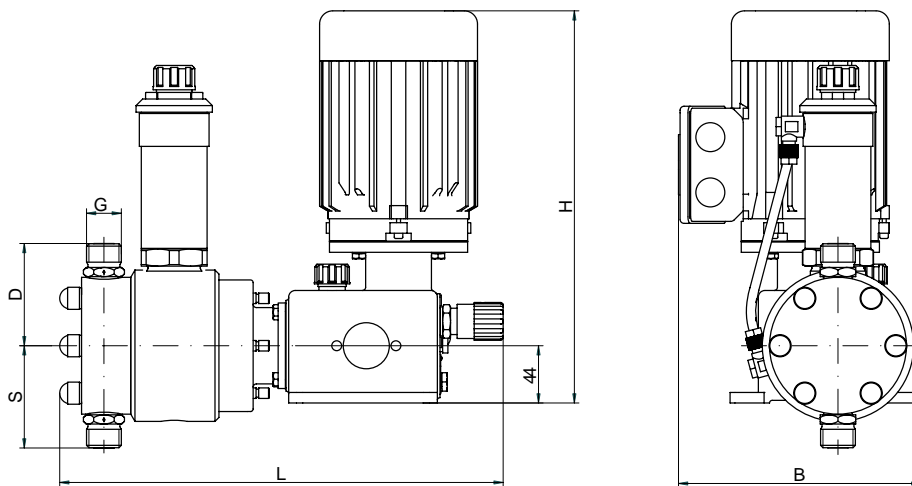

Dimensional chart

All indications in mm

Type	G	S	D	L	B	H	Weight kg
R409.1-...KM	G 3/4	62	62	297	184	271	14.5
R409.1-11KM/14	G 3/4	62	62	297	184	271	14.5
R409.1-17KM/20	G 3/4	62	62	297	184	298	14.5
R409.1-23KM/20	G 3/4	62	62	297	184	298	14.5
R409.1-34KM/28	G 3/4	77	77	350	184	298	20
R409.1-45KM/28	G 3/4	77	77	350	184	298	20
R409.1-68KM/40	G 3/4	77	77	350	184	298	20
R409.1-90KM/40	G 3/4	77	77	350	184	298	20
R409.1-135KM/56	G 3/4	77	77	350	184	298	20
R409.1-180KM/56	G 3/4	77	77	350	184	298	20

Indication of weight for Basic design acc. to order information

Order information

Basic design

R409.1-...KM:

- Pump body PP
- Double valves PP-FRP
- Valve balls glass
- Valve seals FPM
- Diaphragm waved PTFE







Motor:

- 200-254/346-440 V 50 Hz / 200-280/346-480 V 60 Hz threephase, IP 55, insul. cl.F

Further options and accessories:

- Connection pieces see chapter 4
- Product documentation see chapter 5

Type	Basic design	x
R409.1-8,5KM/14	16003766	
R409.1-11KM/14	16003954	
R409.1-17KM/20	16002277	
R409.1-23KM/20	16003955	
R409.1-34KM/28	16004453	
R409.1-45KM/28	16002967	
R409.1-68KM/40	16004506	
R409.1-90KM/40	16001593	
R409.1-135KM/56	16004029	
R409.1-180KM/56	16002073	

Options/Accessories			R409.1-8,5KM/14 up to R409.1-23KM/20	x	R409.1-34KM/28 R409.1-45KM/28	x	R409.1-68KM/40 up to R409.1-180KM/56	x	
	PP	double valves PP-FRP	●		●		●		
		single valves PVC-U	–		▲		▲		
	PVC-U	chamber valves (double valves) PVC-U	▲		–		–		
		PVDF	double valves PVDF-FRP	▲		▲		▲	
		double valves 1.4571/1.4581	–		▲		▲		
1.4571	chamber valves (double valves) 1.4571	▲		–		–			
	Glass	single valves	–		○		○		
		double valves	●		●		●		
	1.4401	single valves	–		○		○		
		double valves	○		○		○		
	PTFE	single valves	–		▲		▲		
		double valves	▲		▲		▲		
	FPM	single valves	–		○		○		
		double valves	●		●		●		
	EPDM	single valves	–		○		○		
		double valves	○		○		○		
	FEP-covered	single valves	–		▲		▲		
		double valves	▲		▲		▲		
	Diaphragm ring (1.4571) incl. diaphragm made of waved PTFE		▲		▲		▲		
	Diaphragm rupture monitoring								
	Diaphragm rupture electrode conductive, mounted to pump								
	MBE-04		▲		▲		▲		
	ATEX-design (Type examination checked, only for piston-double-diaphragm-design)								
	MBE-04 incl. Connection cable for Diaphragm rupture monitoring blue for EExia-circuit (5m)		▲		▲		▲		
	Buffer fluid glycol-glycerine-mixture 1:25 for media with conductivity <= 5µS/cm		▲		▲		▲		
● = Basic design ▲ = with add. price ○ = without add. price – = not available Art.-Nr. = available in basic design/accessories									

Order information

Basic design

R409.1-...KM:

- Pump body PP
- Double valves PP-FRP
- Valve balls glass
- Valve seals FPM
- Diaphragm waved PTFE





Motor:

- 200-254/346-440 V 50 Hz / 200-280/346-480 V 60 Hz threephase, IP 55, insul. cl.F

Further options and accessories:

- Connection pieces see chapter 4
- Product documentation see chapter 5

Type	Basic design	x
R409.1-8,5KM/14	16003766	
R409.1-11KM/14	16003954	
R409.1-17KM/20	16002277	
R409.1-23KM/20	16003955	
R409.1-34KM/28	16004453	
R409.1-45KM/28	16002967	
R409.1-68KM/40	16004506	
R409.1-90KM/40	16001593	
R409.1-135KM/56	16004029	
R409.1-180KM/56	16002073	

Options/Accessories		R409.1-8,5KM/14 up to R409.1-23KM/20 x	R409.1-34KM/28 R409.1-45KM/28 x	R409.1-68KM/40 up to R409.1-180KM/56 x	
Diaphragm rupture monitoring 	Electrode relay, control cabinet assembly				
	ER-104/C	aux. energy 230 V AC	90022994	90022994	90022994
		aux. energy 24 V DC	90022945	90022945	90022945
	ER-142	aux. energy 230 V AC II(1)G [EExia] IIC acc. to ATEX 95	90200363	90200363	90200363
Stroke length adjustment 	with position indicator	▲	▲	▲	
Stroke frequency monitoring 	Inductive contact				
	10-60 V DC, three-wire, PNP	▲	▲	▲	
	Namur execution, II2G EExia IICT6 acc. to ATEX95	▲	▲	▲	
Drive motor 	Special voltage	▲	▲	▲	
	Enclosure IP 65	▲	▲	▲	
	Protective roof for the fan of the drive	▲	▲	▲	
	Integrated posistor (3 pcs.) insul. cl. F	▲	▲	▲	
	VIK-design	▲	▲	▲	
	II2G EExe IIT4 (acc. to ATEX95)	▲	▲	▲	
	II2G EExde IICT4 (acc. to ATEX95)	▲	▲	▲	
	Single phase AC 230V with capacitor	▲	▲	▲	
	Driver for converter operation incl. posistor, 5-100 Hz	▲	▲	▲	
Driver for converter operation II2G EExde IICT4, 5-100 Hz gem. ATEX 95, incl. integrated posistor	▲	▲	▲		
● = Basic design ▲ = with add. price ○ = without add. price – = not available Art.-Nr. = available in basic design/accessories					

Order information

Basic design

R409.1-...KM:

- Pump body PP
- Double valves PP-FRP
- Valve balls glass
- Valve seals FPM
- Diaphragm waved PTFE





Motor:

- 200-254/346-440 V 50 Hz / 200-280/346-480 V 60 Hz threephase, IP 55, insul. cl.F

Further options and accessories:

- Connection pieces see chapter 4
- Product documentation see chapter 5

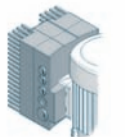
Type	Basic design	x
R409.1-8,5KM/14	16003766	
R409.1-11KM/14	16003954	
R409.1-17KM/20	16002277	
R409.1-23KM/20	16003955	
R409.1-34KM/28	16004453	
R409.1-45KM/28	16002967	
R409.1-68KM/40	16004506	
R409.1-90KM/40	16001593	
R409.1-135KM/56	16004029	
R409.1-180KM/56	16002073	

Options/Accessories		R409.1-8,5KM/14 up to R409.1-23KM/20	x	R409.1-34KM/28 R409.1-45KM/28	x	R409.1-68KM/40 up to R409.1-180KM/56	x
Stroke length adjustment electrical 	Actuator N C1-BA 230 V, +/- 10%, 50/60 Hz, 128s/10 U, 1,5 Nm incl. mounting plate for actuator	▲		▲		▲	
	Electronic positioning controller PMR3 input signal 0/4-20 mA incl. feedback signal 0/4-20 mA (only in N C1-BA integrated)	▲		▲		▲	
	Actuator D30D-10-Ex (II2G EExde IICT4) acc. to ATEX 95, 400 V, 50 Hz, 10 U/min, incl. mounting-kit for actuator and base plate	▲		▲		▲	
Stroke length adjustment pneumatical 	Actuator WPD-4P-60 positioning controller CT 720 control air 6 bar, intake air pressure 3-10 bar IP 65, incl. mounting kit for actuator	▲		▲		▲	
Stroke frequency adjustment electrical 	Frequency converter series 8200 Motec mounted-on, input 4-20mA						
	Single-phase 230 V, 50/60 Hz 0.25 kW	▲		▲		▲	
	Three-phase 320-550 V, +/- 0%, 0.55 kW 50/60 Hz	▲		▲		▲	
	Switch-potentiometer for manual stroke frequency adjustment and to switch on the pump motor (External control of the frequency converter with mounted switch potentiometer unit is not possible)	▲		▲		▲	
	Service module hand terminal and keypad incl. 2,5m connection cable	▲		▲		▲	
Stroke frequency adjustment electrical 	Frequency converter series 8200 Vector input 4-20mA, incl. Keypad (for integration into control cabinet)						
	Single-phase 230 V, 50/60 Hz 0.25 kW		90017521		–		–
	Single-phase 230 V, 50/60 Hz 0.37 kW		–		90017522		90017522
	Three-phase 320-550 V, +/- 0%, 0.55 kW 50/60 Hz		90017526		90017526		90017526
● = Basic design ▲ = with add. price ○ = without add. price – = not available Art.-Nr. = available in basic design/accessories							

Piston diaphragm pumps

Flow capacity 8,5 l/h ... 180 l/h

Admissible counterpressure up to 50 bar



R409.1-...KM

Order information

Basic design

R409.1-...KM:

- Pump body PP
- Double valves PP-FRP
- Valve balls glass
- Valve seals FPM
- Diaphragm waved PTFE

Motor:

- 200-254/346-440 V 50 Hz / 200-280/346-480 V 60 Hz threephase, IP 55, insul. cl.F

Further options and accessories:

- Connection pieces see chapter 4
- Product documentation see chapter 5

Type	Basic design	x
R409.1-8,5KM/14	16003766	
R409.1-11KM/14	16003954	
R409.1-17KM/20	16002277	
R409.1-23KM/20	16003955	
R409.1-34KM/28	16004453	
R409.1-45KM/28	16002967	
R409.1-68KM/40	16004506	
R409.1-90KM/40	16001593	
R409.1-135KM/56	16004029	
R409.1-180KM/56	16002073	

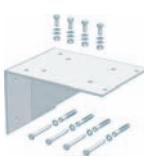
Options/Accessories	R409.1-8,5KM/14 up to R409.1-23KM/20	x	R409.1-34KM/28 R409.1-45KM/28	x	R409.1-68KM/40 up to R409.1-180KM/56	x
	Console  for wall mounting incl. fixing screws 1.4301 PP	90023875		90023875		90023875
	90023848		90023848		90023848	

● = Basic design ▲ = with add. price ○ = without add. price – = not available Art.-Nr. = available in basic design/accessories

2

Fittings for suction side of dosing pumps		R409.1-8,5KM/14 R409.1-11KM/14		R409.1-17KM/20 R409.1-23KM/20		R409.1-34KM/28 R409.1-45KM/28		R409.1-68KM/40		R409.1-90KM/40		R409.1-135KM/56 R409.1-180KM/56	
		Type	p.	Type	p.	Type	p.	Type	p.	Type	p.	Type	p.
Suction lance	with level switch 1-stage	SL-11.1	3.36	SL-11.1	3.36	SL-02	3.34	SL-02	3.34	SL-02	3.34	SL-02	3.34
		⊗		⊗		S-03	3.38	S-03	3.38	S-03	3.38	S-03	3.38
	with level switch 2-stage	SL-12.1	3.36	SL-12.1	3.36	SL-02	3.34	SL-02	3.34	SL-02	3.34	SL-02	3.34
	without level switch	S-01	3.42	S-01	3.42	S-01	3.42	S-01	3.42	S-01	3.42	S-01	3.42
Suction aid / Siphon Vessel	transparent PVC-U	770.2	3.74	770.2	3.74	770.2	3.74	770.2	3.74	770.2	3.74	770.2	3.74
Calibration Pot	PVC-U	791.1	3.76	792.1	3.76	792.1	3.76	793.1	3.76	793.1	3.76	794.1	3.76
Foot valve	PVC-U	731	3.78	731	3.78	731	3.78	731	3.78	731	3.78	731	3.78
	PP-FRP / PVDF-FRP	781.1	3.82	781.1	3.82	781.1	3.82	781.1	3.82	781.1	3.82	781.1	3.82
	1.4571	731	3.78	731	3.78	731	3.78	731	3.78	731	3.78	731	3.78
Line strainer	PVC-U	751.1	3.84	751.1	3.84	751.1	3.84	751.1	3.84	751.1	3.84	751.1	3.84
	PVC-U / PP / PVDF	752.1	3.84	752.1	3.84	752.1	3.84	752.1	3.84	752.1	3.84	752.1	3.84
	1.4408	752	3.86	752	3.86	752	3.86	752	3.86	752	3.86	752	3.86
Float valve	PVC-U	871	3.88	871	3.88	871	3.88	871	3.88	871	3.88	871	3.88
Pulsation damper without separating diaphragm	PVC-U / PP	702.1	3.14	702.1	3.14	702.1	3.14	702.1	3.14	702.1	3.14	702.1	3.14
	1.4571	802.1	3.18	802.1	3.18	802.1	3.18	802.1	3.18	802.1	3.18	802.1	3.18
Fittings for pressure side of dosing pumps		R409.1-8,5KM/14 R409.1-11KM/14		R409.1-17KM/20 R409.1-23KM/20		R409.1-34KM/28 R409.1-45KM/28		R409.1-68KM/40		R409.1-90KM/40		R409.1-135KM/56 R409.1-180KM/56	
		Type	p.	Type	p.	Type	p.	Type	p.	Type	p.	Type	p.
Diaphragm-type relief valve		620.10	3.4	620.10	3.4	620.10	3.4	620.10	3.4	622.10	3.4	622.10	3.4
	for suspension	⊗		⊗		⊗		⊗		622.S	3.6	622.S	3.6
Diaphragm-type pressure keeping valve		620.D	3.8	620.D	3.8	620.D	3.8	620.D	3.8	622.D	3.8	622.D	3.8
Multi-function valve	4 bar opening pressure	MFV 05004	3.10	MFV 05004	3.10	MFV 05004	3.10	-		-		-	
	6 bar opening pressure	MFV 05006	3.10	MFV 05006	3.10	MFV 05006	3.10	-		-		-	
	10 bar opening pressure	MFV 05010	3.10	MFV 05010	3.10	MFV 05010	3.10	-		-		-	
Pulsation damper without separating diaphragm	PVC-U / PP	702.1	3.14	702.1	3.14	702.1	3.14	702.1	3.14	702.1	3.14	702.1	3.14
	1.4571	802.1	3.18	802.1	3.18	802.1	3.18	802.1	3.18	802.1	3.18	802.1	3.18
Diaphragm-pulsation damper with PTFE/PTFE-faced diaphragm	PVC-U / PP / PVDF	720.1	3.24	720.1	3.24	721.2	3.24	722.1	3.24	722.1	3.24	722.1	3.24
Diaphragm-pulsation damper with Elastomer-diaphragm	1.4571	810.1-0,16/180	3.30	810.1-0,16/180	3.30	810.1-0,16/180	3.30	810.1-0,32/160	3.30	810.1-0,32/160	3.30	810.1-0,32/160	3.30
Check valve	PVC-U	661.2	3.48	661.2	3.48	661.2	3.48	661.2	3.48	661.2	3.48	661.2	3.48
	PP-FRP / PVDF-FRP	661.2	3.48	661.2	3.48	661.2	3.48	661.2	3.48	661.2	3.48	661.2	3.48
	1.4571	661.2	3.48	661.2	3.48	661.2	3.48	661.2	3.48	661.2	3.48	661.2	3.48
Dosing valve	PVC-U	691.1	3.54	691.1	3.54	691.1	3.54	691.1	3.54	691.1	3.54	691.1	3.54
	PVC-U / PP / PVDF	681.1	3.58	681.1	3.58	681.1	3.58	681.1	3.58	681.1	3.58	681.1	3.58
	PP-FRP / PVDF-FRP	691.1	3.54	691.1	3.54	691.1	3.54	691.1	3.54	691.1	3.54	691.1	3.54
	1.4571	691.1	3.54	691.1	3.54	691.1	3.54	691.1	3.54	691.1	3.54	691.1	3.54
Injection fitting	PVC-U / PP / PVDF	8061.1	3.60	8061.1	3.60	8061.1	3.60	8061.1	3.60	8061.1	3.60	8061.1	3.60

⊗ = on request - = not available

The above allocation considers the fittings which have to be used at least regarding their nominal width in order to ensure the safe and trouble-free operation of the respective pumps when feeding liquids which are resembling to water.

Absolutely note the max. admissible operating pressure of the fittings.

The use of fittings of a bigger nominal width is unproblematically possible in most cases.

When choosing the fittings note the installation instructions for dosing pumps or confer with s e r a.

Piston diaphragm pumps

Flow capacity 30 l/h ... 1080 l/h

Admissible counterpressure up to 50 bar



R411.1-...KM



R411.1-...KM in survey

- Compact design
- High dosing accuracy
- Safe to run dry
- High quality materials
- Leakage-free
- User-friendly
- Integrateable into automatic processes
- Manual stroke length adjustment
- Robust metallic stroke mechanism housing

Infobox

- Order information [Page 2.109](#)
- Options/accessories [Page 2.109](#)
- fittings-allocation [Page 2.113](#)
- connecting pieces [Chapter 4](#)
- resistance chart [Chapter 5](#)
- installation examples [Chapter 5](#)

Technical data

Type	Nominal capacity		Nominal stroke frequency		Admissible counter-pressure	Admissible pressure at pump inlet	Max. suction height	Inlet/ Outlet nominal width	Max. stroke length	Motor output
	50 Hz	60 Hz	50 Hz	60 Hz						
R411.1-30KM/28	0 - 30	0 - 36	97	116	50	-0.2 / 0	2	10	10	0.75
R411.1-47KM/40	0 - 47	0 - 56	76	92	50	-0.2 / 0	2	10	10	0.75
R411.1-60KM/40	0 - 60	0 - 72	97	116	50	-0.2 / 0	2	10	10	0.75
R411.1-150KM/56	0 - 150	0 - 180	76	92	40	-0.2 / 0	2	15	15	1.1
R411.1-190KM/56	0 - 190	-	97	-	40	-0.2 / 0	2	15	15	1.1
R411.1-300KM/80	0 - 300	0 - 360	76	92	20	-0.2 / 0	2	15	15	1.1
R411.1-390KM/80	0 - 390	-	97	-	20	-0.2 / 0	2	15	15	1.1
R411.1-510KM/100	0 - 510	0 - 610	76	92	15	-0.2 / 0	2	15	15	1.1
R411.1-640KM/100	0 - 640	-	97	-	15	-0.2 / 0	2	20	15	1.1
R411.1-840KM/115	0 - 840	-	97	-	11	-0.2 / 0	2	20	15	1.1
R411.1-900KM/115	0 - 900	0 - 1.080	76	92	8	-0.2 / 0	2	20	20	1.1

Note: The admissible counterpressure is 10 bar or lower when plastic pump bodies are used.

Dimensional drawing

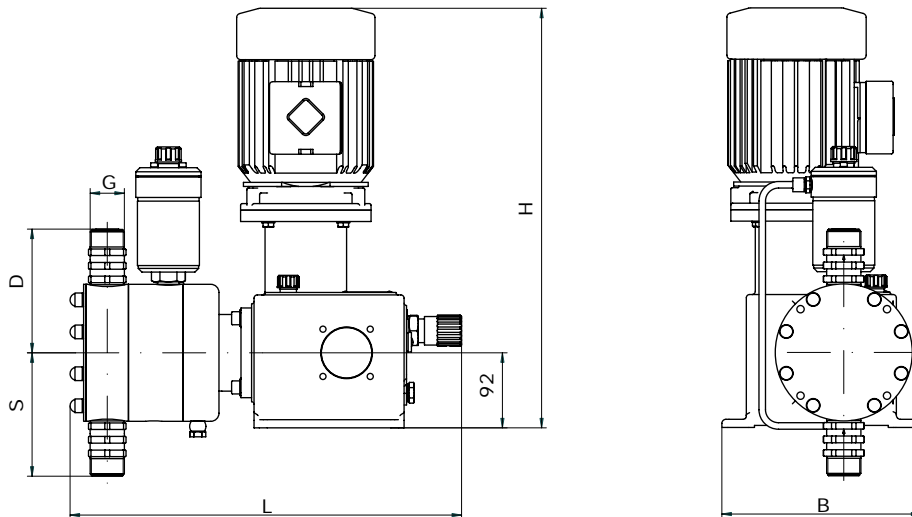

Dimensional chart

All indications in mm

Type	G	S	D	L	B	H	Weight kg
R411.1-30KM/28	G 3/4	77	77	466	244	486	58
R411.1-47KM/40	G 3/4	77	77	466	244	486	58
R411.1-60KM/40	G 3/4	77	77	466	244	486	58
R411.1-150KM/56	G 1 1/4	152	152	492	244	516	62.5
R411.1-190KM/56	G 1 1/4	152	152	492	244	516	62.5
R411.1-300KM/80	G 1 1/4	152	152	492	244	516	62.5
R411.1-390KM/80	G 1 1/4	152	152	492	244	516	62.5
R411.1-510KM/100	G 1 1/4	152	152	492	244	516	61
R411.1-640KM/100	G 1 1/4	152	152	492	244	516	61
R411.1-840KM/115	G 1 1/4	178	178	586	244	516	89
R411.1-900KM/115	G 1 1/4	178	178	586	244	516	89

Indication of weight for Basic design acc. to order information

Order information

Basic design

R411.1-...KM

- Pump body PP
- Double valves PP-FRP
- Valve balls glass
- Valve seals FPM
- Diaphragm waved PTFE





Motor:

- 200-254/346-440 V 50 Hz / 200-280/346-480 V 60 Hz threephase, IP 55, insul. cl. F

Further options and accessories

- Connection pieces see chapter 4
- Product documentation see chapter 5

Type	Basic design	x
R411.1-30KM/28	16006645	
R411.1-47KM/40	16007862	
R411.1-60KM/40	16005828	
R411.1-150KM/56	16004523	
R411.1-190KM/56	16003827	
R411.1-300KM/80	16000480	
R411.1-390KM/80	16003291	
R411.1-510KM/100	16001771	
R411.1-640KM/100	16001392	
R411.1-840KM/115	16005458	
R411.1-900KM/115	16003803	

Options/Accessories		R411.1-30KM/28 R411.1-47KM/40	R411.1-60KM/40	R411.1-150KM/56 R411.1-190KM/56	R411.1-300KM/80 up to R411.1-640KM/100	R411.1-840KM/115 R411.1-900KM/115	
Pump body and valves 	PP double valves PP-FRP	●	●	●	●	●	
	PVC-U single valves PVC-U	▲	▲	▲	▲	▲	
	PVDF double valves PVDF-FRP	▲	▲	▲	▲	▲	
	1.4571	single valves 1.4571/1.4581	▲	▲	▲	▲	▲
		double valves 1.4571/1.4581	▲	▲	▲	▲	▲
Valve balls 	Glass	single valves	○	○	○	○	
		double valves	●	●	●	●	●
	1.4401	single valves	○	○	▲	▲	▲
		double valves	○	○	▲	▲	▲
	PTFE	single valves	▲	▲	▲	▲	▲
		double valves	▲	▲	▲	▲	▲
Valve sealings 	FPM	single valves	○	○	○	○	
		double valves	●	●	●	●	●
	EPDM	single/double valves	○	○	○	○	
	FEP-covered	single valves	▲	▲	▲	▲	▲
		double valves	▲	▲	▲	▲	▲
Piston-double diaphragm design 	Diaphragm ring (1.4571) incl. diaphragm made of waved PTFE	▲	▲	▲	▲	-	
	Diaphragm ring (nickel-plated C-steel) incl. diaphragm PTFE-well	-	-	-	-	▲	
Diaphragm rupture monitoring 	Diaphragm rupture electrode conductive, mounted to pump						
	MBE-04	▲	▲	▲	▲	▲	

● = Basic design ▲ = with add. price ○ = without add. price ⊗ = on request -- = not available Art.-Nr. = available in basic design/accessories

Piston diaphragm pumps

Flow capacity 30 l/h ... 1080 l/h

Admissible counterpressure up to 50 bar



R411.1-...KM

Order information

Basic design

R411.1-...KM

- Pump body PP
- Double valves PP-FRP
- Valve balls glass
- Valve seals FPM
- Diaphragm waved PTFE

Motor:



- 200-254/346-440 V 50 Hz / 200-280/346-480 V 60 Hz threephase, IP 55, insul. cl. F

Further options and accessories

- Connection pieces see chapter 4
- Product documentation see chapter 5

Type	Basic design	x
R411.1-30KM/28	16006645	
R411.1-47KM/40	16007862	
R411.1-60KM/40	16005828	
R411.1-150KM/56	16004523	
R411.1-190KM/56	16003827	
R411.1-300KM/80	16000480	
R411.1-390KM/80	16003291	
R411.1-510KM/100	16001771	
R411.1-640KM/100	16001392	
R411.1-840KM/115	16005458	
R411.1-900KM/115	16003803	

2

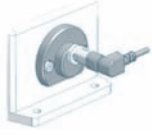
Options/Accessories		R411.1-30KM/28 R411.1-47KM/40	R411.1-60KM/40	R411.1-150KM/56 R411.1-190KM/56	R411.1-300KM/80 up to R411.1-640KM/100	R411.1-840KM/115 R411.1-900KM/115	
 Diaphragm rupture monitoring	ATEX-design (Type examination checked, only for piston-double-diaphragm-design)						
	MBE-04 incl. Connection cable for Diaphragm rupture monitoring blue for EExia-circuit (5m)	▲	▲	▲	▲	▲	
	Buffer fluid glycol-glycerine-mixture 1:25 for media with conductivity <= 5µS/cm	▲	▲	▲	▲	▲	
 Diaphragm rupture monitoring	Electrode relay, control cabinet assembly						
	ER-104/C	aux. energy 230 V AC	90022994	90022994	90022994	90022994	90022994
		aux. energy 24 V DC	90022945	90022945	90022945	90022945	90022945
ER-142	aux. energy 230 V AC II(1)G [EExia] IIC acc. to ATEX 95	90200363	90200363	90200363	90200363	90200363	
 Stroke length adjustment	with position indicator	▲	▲	▲	▲	▲	
 Stroke frequency monitoring	Inductive contact						
	10-60 V DC, three-wire, PNP	▲	▲	▲	▲	▲	
	Namur execution, II2G EExia IIC T6 acc. to ATEX95	▲	▲	▲	▲	▲	
<p>● = Basic design ▲ = with add. price ○ = without add. price Ⓞ = on request – = not available Art.-Nr. = available in basic design/accessories</p>							

Order information

Basic design

R411.1-...KM

- Pump body PP
- Double valves PP-FRP
- Valve balls glass
- Valve seals FPM
- Diaphragm waved PTFE



Motor:

- 200-254/346-440 V 50 Hz / 200-280/346-480 V 60 Hz threephase, IP 55, insul. cl. F

Further options and accessories

- Connection pieces see chapter 4
- Product documentation see chapter 5

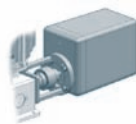
Type	Basic design	x
R411.1-30KM/28	16006645	
R411.1-47KM/40	16007862	
R411.1-60KM/40	16005828	
R411.1-150KM/56	16004523	
R411.1-190KM/56	16003827	
R411.1-300KM/80	16000480	
R411.1-390KM/80	16003291	
R411.1-510KM/100	16001771	
R411.1-640KM/100	16001392	
R411.1-840KM/115	16005458	
R411.1-900KM/115	16003803	

Options/Accessories		R411.1-30KM/28 R411.1-47KM/40	R411.1-60KM/40	R411.1-150KM/56 R411.1-190KM/56	R411.1-300KM/80 up to R411.1-640KM/100	R411.1-840KM/115 R411.1-900KM/115
Drive motor 	Special voltage	▲	▲	▲	▲	▲
	Enclosure IP 65	▲	▲	▲	▲	▲
	Protective roof for the fan of the drive	▲	▲	▲	▲	▲
	Integrated posistor (3 pcs.) insul. cl. F	▲	▲	▲	▲	▲
	VIK-design	▲	▲	▲	▲	▲
	II2G EExe IIT4 (acc. to ATEX95)	▲	▲	▲	▲	▲
	II2G EExde ICT4 (acc. to ATEX95)	▲	▲	▲	▲	▲
	Single phase AC 230V with capacitor	▲	▲	▲	▲	▲
	Driver for converter operation incl. integrated posistor, 5-50/60Hz	▲	▲	▲	▲	▲
	Driver for converter operation II2G EExde ICT4, 5-50/60 Hz gem. ATEX 95, incl. integrated posistor	▲	▲	▲	▲	▲
Stroke length adjustment electrical 	Actuator N1S 230 V, 50/60 Hz, 128s/10 U, 15 Nm Potentiometer 1 kOhm incl. mounting kit for actuator	▲	▲	▲	▲	▲
	Electronic positioning controller PMR3 input signal 0/4-20 mA incl. feedback signal 0/4-20 mA (only in N 1S integrated)	▲	▲	▲	▲	▲
	Actuator D30D-10-Ex (II2G EExde ICT4) acc. to ATEX 95, 400 V, 50 Hz, 10 U/min, incl. mounting-kit for actuator and base plate	▲	▲	▲	▲	▲
Stroke length adjustment pneumatical 	Actuator WPD-4P-150 positioning controller CT 720 control air 6 bar, intake air pressure 3-10 bar, IP 65, incl. mounting kit for actuator	▲	▲	▲	▲	▲
<p>● = Basic design ▲ = with add. price ○ = without add. price ⊕ = on request -- = not available Art.-Nr. = available in basic design/accessories</p>						

R411.1-...KM

Order information

Basic design

R411.1-...KM

- Pump body PP
- Double valves PP-FRP
- Valve balls glass
- Valve seals FPM
- Diaphragm waved PTFE

Motor:



- 200-254/346-440 V 50 Hz / 200-280/346-480 V 60 Hz threephase, IP 55, insul. cl. F

Further options and accessories

- Connection pieces see chapter 4
- Product documentation see chapter 5

Type	Basic design	x
R411.1-30KM/28	16006645	
R411.1-47KM/40	16007862	
R411.1-60KM/40	16005828	
R411.1-150KM/56	16004523	
R411.1-190KM/56	16003827	
R411.1-300KM/80	16000480	
R411.1-390KM/80	16003291	
R411.1-510KM/100	16001771	
R411.1-640KM/100	16001392	
R411.1-840KM/115	16005458	
R411.1-900KM/115	16003803	

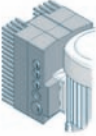
2

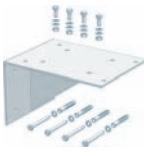
Options/Accessories		R411.1-30KM/28 R411.1-47KM/40	R411.1-60KM/40	R411.1-150KM/56 R411.1-190KM/56	R411.1-300KM/80 up to R411.1-640KM/100	R411.1-840KM/115 R411.1-900KM/115
Stroke frequency adjustment electrical 	Frequency converter series 8200 Motec mounted-on, input 4-20mA	x	x	x	x	x
	Three-phase 0.75 kW 320-550 V, +/- 0%, 50/60 Hz	▲	▲	-	-	-
	1.5 kW	-	-	▲	▲	▲
	Switch-potentiometer for manual stroke frequency adjustment and to switch on the pump motor (External control of the frequency converter with mounted switch potentiometer unit is not possible)	▲	▲	▲	▲	▲
Service module hand terminal and keypad incl. 2,5m connection cable	▲	▲	▲	▲	▲	
Stroke frequency adjustment electrical 	Frequency converter series 8200 Vector input 4-20mA, incl. Keypad (for integration into control cabinet)					
	Single-phase 0.75 kW 230 V, 50/60 Hz	90017524	90017524	-	-	-
	1.5 kW	-	-	90016865	90016865	90016865
	Three-phase 0.75 kW 320-550 V, +/- 0%, 50/60 Hz	90017527	90017527	-	-	-
1.5 kW	-	-	90017528	90017528	90017528	
Console 	for wall mounting incl. fixing screws					
	1.4301	⊙	⊙	⊙	⊙	⊙
PP						
		⊙	⊙	⊙	⊙	⊙

● = Basic design ▲ = with add. price ○ = without add. price ⊙ = on request - = not available Art.-Nr. = available in basic design/accessories

Fittings for suction side of dosing pumps		R411.1-30KM/28 up to R411.1-60KM/40		R411.1-150KM/56 R411.1-190KM/56		R411.1-300KM/80 up to R411.1-510KM/100		R411.1-640KM/100		R411.1-840KM/115 R411.1-900KM/115	
		Type	p.	Type	p.	Type	p.	Type	p.	Type	p.
Suction lance	with level switch 1-stage	SL-02	3.34	⊗		S-04	3.40	⊗		⊗	
		S-03	3.38	⊗		⊗		⊗		⊗	
	with level switch 2-stage	SL-02	3.34	⊗		⊗		⊗		⊗	
		without level switch	S-01	3.42	S-01	3.42	S-01	3.42	S-01	3.42	S-01
Suction aid / Siphon Vessel	transparent PVC-U	770.2	3.74	770.2	3.74	770.2	3.74	771.2	3.74	771.2	3.74
Calibration Pot	PVC-U	792.1	3.76	794.1	3.76	795.1	3.76	795.1	3.76	796.1	3.76
Foot valve	PVC-U	731	3.78	732.2	3.80	732.2	3.80	733.2	3.80	734.2	3.80
	PP / PVDF	⊗		732	3.78	732	3.78	733	3.78	733	3.78
	1.4571	781.1	3.82	783.1	3.82	783.1	3.82	783.1	3.82	⊗	
	PP-FRP / PVDF-FRP	731	3.78	732	3.78	732	3.78	733	3.78	733	3.78
Line strainer	PVC-U / PP / PVDF	751.1	3.84	⊗		⊗		⊗		⊗	
	1.4408	752.1	3.84	752.1	3.84	752.1	3.84	753.1	3.84	753.1	3.84
	PVC-U	752	3.86	752	3.86	752	3.86	753	3.86	753	3.86
Float valve	PVC-U	871	3.88	872	3.88	872	3.88	872	3.88	873	3.88
Pulsation damper without separating diaphragm	PVC-U / PP	702.1	3.14	702.1	3.14	702.1	3.14	702.1	3.14	703.1	3.14
	1.4571	802.1	3.18	802.1	3.18	802.1	3.18	802.1	3.18	803.1	3.18
Fittings for pressure side of dosing pumps		R411.1-30KM/28 up to R411.1-60KM/40		R411.1-150KM/56 R411.1-190KM/56		R411.1-300KM/80 up to R411.1-510KM/100		R411.1-640KM/100		R411.1-840KM/115 R411.1-900KM/115	
		Type	p.	Type	p.	Type	p.	Type	p.	Type	p.
Diaphragm-type relief valve		620.10	3.4	622.10	3.4	622.10	3.4	623.10	3.4	623.10	3.4
	for suspension	⊗		622.S	3.6	622.S	3.6	623.S	3.6	623.S	3.6
Diaphragm-type pressure keeping valve		620.D	3.8	622.D	3.8	622.D	3.8	623.D	3.8	623.D	3.8
Pulsation damper without separating diaphragm	PVC-U / PP	702.1	3.14	702.1	3.14	702.1	3.14	702.1	3.14	703.1	3.14
	1.4571	802.1	3.18	802.1	3.18	802.1	3.18	802.1	3.18	803.1	3.18
Diaphragm-pulsation damper with Elastomer-diaphragm	PVC-U / PP / PVDF	713.1	3.20	713.1	3.20	713.1	3.20	713.1	3.20	713.1	3.20
	1.4571	713.1	3.22	713.1	3.22	713.1	3.22	713.1	3.22	713.1	3.22
		810.1-0,32/160	3.30	810.1-0,75/140	3.30	810.1-0,75/140	3.30	810.1-0,75/140	3.30	810.1-2,0/100	3.30
Diaphragm-pulsation damper with PTFE/PTFE-faced diaphragm	PVC-U / PP / PVDF	721.2	3.24	723.1	3.24	723.1	3.24	723.1	3.24	⊗	
	1.4571	721.1	3.28	723.1	3.28	723.1	3.28	723.1	3.28	724.1	3.28
Check valve	PVC-U	661.2	3.48	⊗		⊗		⊗		⊗	
	PP-FRP / PVDF-FRP	661.2	3.48	⊗		⊗		⊗		⊗	
	1.4571	661.2	3.48	662.2	3.48	662.2	3.48	663.2	3.48	663.2	3.48
Dosing valve	PP-FRP / PVDF-FRP	691.1	3.54	693.1	3.54	693.1	3.54	693.1	3.54	693.1	3.54
	1.4571	691.1	3.54	692.1	3.54	692.1	3.54	693.1	3.54	693.1	3.54
Injection fitting	PVC-U / PP / PVDF	8061.1	3.60	8062.1	3.60	8062.1	3.60	8063.1	3.60	8063.1	3.60

⊗ = on request

The above allocation considers the fittings which have to be used at least regarding their nominal width in order to ensure the safe and trouble-free operation of the respective pumps when feeding liquids which are resembling to water.

Absolutely note the max. admissible operating pressure of the fittings.

The use of fittings of a bigger nominal width is unproblematically possible in most cases.

When choosing the fittings note the installation instructions for dosing pumps or confer with s e r a.

Piston diaphragm pumps

Flow capacity 1100 l/h ... 1500 l/h

Admissible counterpressure up to 16 bar



413KM



M/R413KM in survey

- Compact design
- High dosing accuracy
- Safe to run dry
- High quality materials
- Leakage - free
- Low-maintenance
- User-friendly
- Integrateable into automatic processes
- Manual stroke frequency adjustment
- Robust metallic stroke mechanism housing

Infobox

- Order information [Page 2.115](#)
- Options/accessories [Page 2.115](#)
- fittings-allocation [Page 2.118](#)
- connecting pieces [Chapter 4](#)
- resistance chart [Chapter 5](#)
- installation examples [Chapter 5](#)

Technical data

Type	Nominal capacity		Nominal stroke frequency		Admissible counter-pressure	Admissible pressure at pump inlet	Max. suction height	Inlet/Outlet nominal width	Max. stroke length	Motor output
	l/h		1/min							
	50 Hz	60 Hz	50 Hz	60 Hz						
R413KM-115/16	220 - 1.100	220 - 1.100	93	93	16	-0.2 / 0	2	20	22	2.2
R413KM-115/16	300 - 1.500	300 - 1.500	85	85	16	-0.2 / 0	2	25	36	3
M413KM-115/16	1.100	1.100	93	93	16	-0.2 / 0	2	20	22	2.2
M413KM-115/16	1.500	1.500	85	85	16	-0.2 / 0	2	25	36	3

Note: The admissible counterpressure is 10 bar when plastic pump bodies are used.

Dimensional drawing

Manual stroke frequency adjustment
(Gear unit)

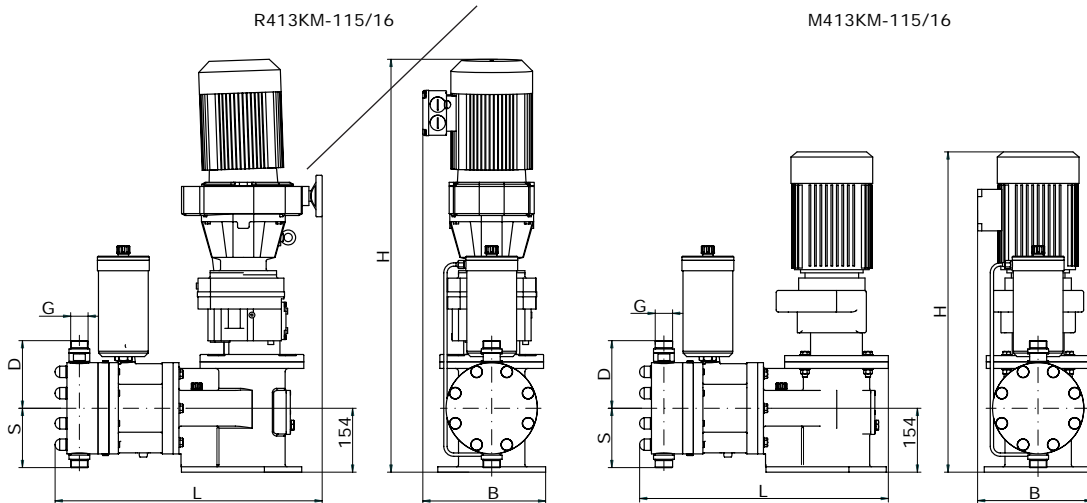

Dimensional chart

All indications in mm

Type	G	S	D	B	H
R413KM-115/16	G 1 1/4	145	163	260	970
R413KM-115/16	G 1 1/2	204	208	260	1084
M413KM-115/16	G 1 1/4	145	163	260	790
M413KM-115/16	G 1 1/2	204	208	260	792

Weights on request

Order information

Basic design

M/R413KM

- Pump body PP
- Single valves PP
- Valve balls DN20=glass DN25=PTFE
- Valve seals FPM
- Diaphragm CSM (Hypalon)







Motor:

- 200-254/346-440 V 50 Hz / 200-280/346-480 V 60 Hz threephase, IP 55, insul cl. F

Further options and accessories

- Connection pieces see Chapter 4
- Product documentation see Chapter 5

Type	Basic design	x
R413KM up to 1100 l/h	15002229	
R413KM up to 1500 l/h	16004546	
M413KM up to 1100 l/h	15002228	
M413KM up to 1500 l/h	16001657	

Options/Accessories				R413KM up to 1100 l/h	x	R413KM up to 1500 l/h	x	M413KM up to 1100 l/h	x	M413KM up to 1500 l/h	x
Pump body and valves 	PP	single valves PP	DN 20	●		–		●		–	
			DN 25	–		●		–		●	
	PVC-U	single valves PVC-U	DN 20	▲		–		▲		–	
			DN 25	–		▲		–		▲	
	PVDF	single valves PVDF	DN 20	▲		–		▲		–	
			DN 25	–		▲		–		▲	
	1.4571	single valves 1.4571	DN 20	▲		–		▲		–	
			DN 25	–		▲		–		▲	
Valve balls 	Glass	single valves	DN 20	●		–		●		–	
			DN 25	–		–		–		–	
	1.4401	single valves	DN 20	▲		–		▲		–	
			DN 25	–		▲		–		▲	
	PTFE	single valves	DN 20	▲		–		▲		–	
			DN 25	–		●		–		●	
Valve sealings 	FPM	single valves	DN 20	●		–		●		–	
			DN 25	–		●		–		●	
	EPDM	single valves	DN 20	○		–		○		–	
			DN 25	–		○		–		○	
	FEP-covered	single valves	DN 20	▲		–		▲		–	
			DN 25	–		▲		–		▲	
Diaphragm 	CSM			●		●		●		●	
			PTFE-WELL	▲		▲		▲		▲	
			FPM	⊙		⊙		⊙		⊙	
Piston-diaphragm design 		Diaphragm ring (nickel-plated C-steel) incl. diaphragm CSM		▲		▲		▲		▲	
Diaphragm rupture monitoring 	Diaphragm rupture electrode conductive, mounted to pump										
			MBE-04	for KM-pumps and KDM-pumps	▲		▲		▲		▲

● = Basic design ▲ = with add. price ○ = without add. price ⊙ = on request – = not available Art.-Nr. = available in basic design/accessories

413KM

Order information

Basic design

M/R413KM

- Pump body PP
- Single valves PP
- Valve balls DN20=glass DN25=PTFE
- Valve seals FPM
- Diaphragm CSM (Hypalon)





Motor:

- 200-254/346-440 V 50 Hz / 200-280/346-480 V 60 Hz threephase, IP 55, insul. cl. F

Further options and accessories

- Connection pieces see Chapter 4
- Product documentation see Chapter 5

Type	Basic design	x
R413KM up to 1100 l/h	15002229	
R413KM up to 1500 l/h	16004546	
M413KM up to 1100 l/h	15002228	
M413KM up to 1500 l/h	16001657	

Options/Accessories		R413KM up to 1100 l/h	R413KM up to 1500 l/h	M413KM up to 1100 l/h	M413KM up to 1500 l/h
Diaphragm rupture monitoring	ATEX-design (Type examination checked, only for piston-double-diaphragm-design)				
	MBE-04 incl. Connection cable for Diaphragm rupture monitoring blue for EExia-circuit (5m)	▲	▲	▲	▲
	Buffer fluid glycol-glycerine-mixture 1:25 for media with conductivity $\leq 5\mu\text{S}/\text{cm}$	▲	▲	▲	▲
Diaphragm rupture monitoring	Electrode relay, control cabinet assembly				
	ER-104/C aux. energy 230 V AC	90022994	90022994	90022994	90022994
	ER-104/C aux. energy 24 V DC	90022945	90022945	90022945	90022945
	ER-142 aux. energy 230 V AC II(1)G [EExia] IIC acc. to ATEX 95	90200363	90200363	90200363	90200363
Drive motor	Special voltage	▲	▲	▲	▲
	Enclosure IP 65	▲	▲	▲	▲
	Protective roof for the fan of the drive	▲	▲	▲	▲
	integrated posistor (3 pcs.) insul. cl. F	▲	▲	▲	▲
	VIK-design	▲	▲	▲	▲
	I12G EExe IIT3 (acc. to ATEX95)	⊙	⊙	⊙	⊙
	I12G EExe IIT4 (acc. to ATEX95)	⊙	⊙	⊙	⊙
	I12G EExde ICT4 (acc. to ATEX95)	⊙	⊙	⊙	⊙
	Driver for converter operation incl. integrated posistor, 5-50/60Hz (not for gear unit)	-	-	▲	▲
Driver for converter operation I12G EExde ICT4, 5-50/60 Hz gem. ATEX 95, incl. integrated posistor	-	-	⊙	⊙	
Stroke frequency control electrical	Frequency converter series 8200 Motec mounted-on, input 4-20mA				
	Three-phase 320-550 V, +/- 0%, 50/60 Hz 2.2 kW	-	-	▲	⊙
	Switch-potentiometer for manual stroke frequency adjustment and to switch on the pump motor (External control of the frequency converter with mounted switch potentiometer unit is not possible)	-	-	▲	⊙
	Service module hand terminal and keypad incl. 2,5m connection cable	-	-	▲	⊙
● = Basic design ▲ = with add. price ○ = without add. price ⊙ = on request - = not available Art.-Nr. = available in basic design/accessories					

Order information

Basic design

M/R413KM

- Pump body PP
- Single valves PP
- Valve balls DN20=glass DN25=PTFE
- Valve seals FPM
- Diaphragm CSM (Hypalon)

Motor:

- 200-254/346-440 V 50 Hz / 200-280/346-480 V 60 Hz threephase, IP 55, insul cl. F

Further options and accessories

- Connection pieces see Chapter 4
- Product documentation see Chapter 5

Type	Basic design	x
R413KM up to 1100 l/h	15002229	
R413KM up to 1500 l/h	16004546	
M413KM up to 1100 l/h	15002228	
M413KM up to 1500 l/h	16001657	

Options/Accessories		R413KM up to 1100 l/h	R413KM up to 1500 l/h	M413KM up to 1100 l/h	M413KM up to 1500 l/h	
Stroke frequency adjustment electrical 	Frequency converter series 8200 Vector input 4-20mA, incl. Keypad (for integration into control cabinet)					
	Single-phase 230 V, 50/60 Hz	2.2 kW	–	–	90017525	–
	Three-phase 320-550 V, +/- 0%, 50/60 Hz	2.2 kW	–	–	90017529	–
		3 kW	–	–	–	90024454
● = Basic design ▲ = with add. price ○ = without add. price ⊕ = on request – = not available Art.-Nr. = available in basic design/accessories						

Fittings for suction side of dosing pumps		R413KM up to 1100 l/h		R413KM up to 1500 l/h		M413KM up to 1100 l/h		M413KM up to 1500 l/h	
		Type	p.	Type	p.	Type	p.	Type	p.
Suction aid / Siphon Vessel	transparent PVC-U	772.2	3.74	772.2	3.74	772.2	3.74	772.2	3.74
Calibration Pot	PVC-U	796.1	3.76	797.1	3.76	796.1	3.76	797.1	3.76
Foot valve	PVC-U	733.2	3.80	734.2	3.80	733.2	3.80	734.2	3.80
	PP / PVDF	733	3.78	734	3.78	733	3.78	734	3.78
	1.4571	733	3.78	734	3.78	733	3.78	734	3.78
Line strainer	PVC-U / PP / PVDF	753.1	3.84	754.1	3.84	753.1	3.84	754.1	3.84
Float valve	PVC-U	873	3.88	874	3.88	873	3.88	874	3.88
Pulsation damper without separating diaphragm	PVC-U / PP	703.1	3.14	706.1	3.14	703.1	3.14	706.1	3.14
	1.4571	803.1	3.18	804.1	3.18	803.1	3.18	804.1	3.18

Fittings for pressure side of dosing pumps		R413KM up to 1100 l/h		R413KM up to 1500 l/h		M413KM up to 1100 l/h		M413KM up to 1500 l/h	
		Type	p.	Type	p.	Type	p.	Type	p.
Diaphragm-type relief valve		623.10	3.4	624.10	3.4	623.10	3.4	624.10	3.4
	for suspension	623.S	3.6	624.S	3.6	623.S	3.6	624.S	3.6
Diaphragm-type pressure keeping valve		623.D	3.8	624.D	3.8	623.D	3.8	624.D	3.8
Pulsation damper without separating diaphragm	PVC-U / PP	703.1	3.14	706.1	3.14	703.1	3.14	706.1	3.14
	1.4571	803.1	3.18	804.1	3.18	803.1	3.18	804.1	3.18
Diaphragm-pulsation damper with Elastomer-diaphragm	PVC-U / PP / PVDF	713.1	3.20	715.1	3.20	713.1	3.20	715.1	3.20
	1.4571	713.1	3.22	715.1	3.22	713.1	3.22	715.1	3.22

The above allocation considers the fittings which have to be used at least regarding their nominal width in order to ensure the safe and trouble-free operation of the respective pumps when feeding liquids which are resembling to water.

Absolutely note the max. admissible operating pressure of the fittings.

The use of fittings of a bigger nominal width is unproblematically possible in most cases.

When choosing the fittings note the installation instructions for dosing pumps or confer with s e r a.

Piston pumps

Flow capacity 7 l/h ... 52 l/h

Admissible counterpressure up to 140 bar



R409.1-...K.1

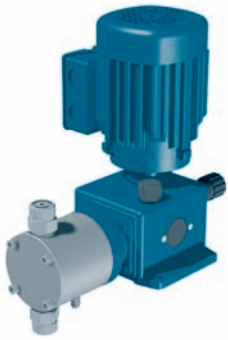

R409.1-...K.1 in survey

- Compact design
- Low maintenance
- High dosing accuracy
- High quality materials
- User-friendly
- Integrateable into automatic processes
- Manual stroke length adjustment
- Robust metallic stroke mechanism housing

Infobox

- Order information [Page 2.121](#)
- Options/accessories [Page 2.121](#)
- fittings-allocation [Page 2.124](#)
- connecting pieces [Chapter 4](#)
- resistance chart [Chapter 5](#)
- installation examples [Chapter 5](#)

Technical data

Type	Nominal capacity		Nominal stroke frequency		Admissible counter-pressure	Admissible pressure at pump inlet	Max. suction height	Inlet/ Outlet nominal width	Max. stroke length	Motor output
	l/h		1/min							
	50 Hz	60 Hz	50 Hz	60 Hz						
R409.1-7K.1/14	0 - 7	0 - 8.4	100	120	80	-0.3 / 0	3	10	8	0.18
R409.1-8,5K.1/14	0 - 8.5	0 - 10.2	100	120	140	-0.3 / 0	3	10	10	0.37
R409.1-11K.1/14	0 - 11	0 - 11	160	160	80	-0.3 / 0	3	10	8	0.18
R409.1-13K.1/14	0 - 13	0 - 13	160	160	140	-0.3 / 0	3	10	10	0.37
R409.1-14K.1/20	0 - 14	0 - 16.8	100	120	40	-0.3 / 0	3	10	8	0.18
R409.1-17K.1/20	0 - 17	0 - 20.4	100	120	80	-0.3 / 0	3	10	10	0.37
R409.1-22K.1/20	0 - 22	0 - 22	160	160	40	-0.3 / 0	3	10	8	0.18
R409.1-26K.1/20	0 - 26	0 - 26	160	160	80	-0.3 / 0	3	10	10	0.37
R409.1-28K.1/28	0 - 28	0 - 33.6	100	120	20	-0.3 / 0	3	10	8	0.18
R409.1-34K.1/28	0 - 34	0 - 40.8	100	120	40	-0.3 / 0	3	10	10	0.37
R409.1-44K.1/28	0 - 44	0 - 44	160	160	20	-0.3 / 0	3	10	8	0.18
R409.1-52K.1/28	0 - 52	0 - 52	160	160	40	-0.3 / 0	3	10	10	0.37

Dimensional drawing

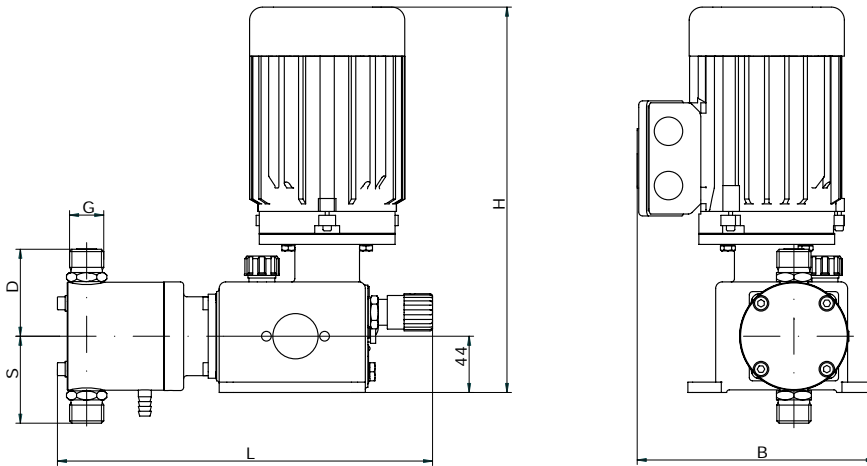

Dimensional chart

All indications in mm

Type	G	S	D	L	B	H	Weight kg
R409.1-7K.1/14	G 3/4	68	68	295	194	278	14
R409.1-8,5K.1/14	G 3/4	68	68	295	194	298	14
R409.1-11K.1/14	G 3/4	68	68	295	194	278	14
R409.1-13K.1/14	G 3/4	68	68	295	194	198	16
R409.1-14K.1/20	G 3/4	68	68	295	194	278	16
R409.1-17K.1/20	G 3/4	68	68	295	194	298	16
R409.1-22K.1/20	G 3/4	68	68	295	194	278	16
R409.1-26K.1/20	G 3/4	68	68	295	194	298	16
R409.1-28K.1/28	G 3/4	68	68	295	194	278	16
R409.1-34K.1/28	G 3/4	68	68	295	194	298	16
R409.1-44K.1/28	G 3/4	68	68	295	194	278	16
R409.1-52K.1/28	G 3/4	68	68	295	194	298	16

Indication of weight for Basic design acc. to order information

Order information

Basic design

R409.1-...K.1

- Pump body 1.4122 V
- Piston 1.4571
- Valve balls 1.4401
- Valve seals FPM
- Piston seal V-seal made of PTFE/PE
- Protective diaphragm made of CR (Neoprene)
- Double Valves made of 1.4571/1.4581



Motor:

- 200-254/346-440 V 50 Hz / 200-280/346-480 V 60 Hz Drehstrom, IP 55, ISO F

Further options and accessories

- Connection pieces see chapter 4
- Product documentation see chapter 5

Type	Basic design	x
R409.1-7K.1/14	16002690	
R409.1-8,5K.1/14	16002493	
R409.1-11K.1/14	16003856	
R409.1-13K.1/14	16000021	
R409.1-14K.1/20	16000801	
R409.1-17K.1/20	16001076	
R409.1-22K.1/20	16000880	
R409.1-26K.1/20	16000804	
R409.1-28K.1/28	16000805	
R409.1-34K.1/28	16000806	
R409.1-44K.1/28	16000807	
R409.1-52K.1/28	16001998	

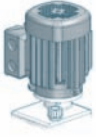
Options/Accessories		R409.1-7K.1/14 R409.1-11K.1/14 R409.1-14K.1/20 R409.1-22K.1/28 R409.1-28K.1/28 R409.1-44K.1/28	R409.1-8,5K.1/14 R409.1-13K.1/14 R409.1-17K.1/20 R409.1-26K.1/20 R409.1-34K.1/28 R409.1-52K.1/28			
	FPM double valves	●	●			
	EPDM double valves	○	○			
	FEP-covered double valves	▲	▲			
	with position indicator	▲	▲			
	Inductive contact					
	10-60 V DC, three-wire, PNP	▲	▲			
	Namur execution, II2G EExia IICT6 acc. to ATEX95	▲	▲			
	Special voltage	▲	▲			
	Enclosure IP 65	▲	▲			
	Protective roof for the fan of the drive	▲	▲			
	Integrated posistor (3 pcs.) insul. cl. F	▲	▲			
	VIK-design	▲	▲			
	II2G EExe IIT4 (acc. to ATEX95)	▲	▲			
	II2G EExde IICT4 (acc. to ATEX95)	▲	▲			
	Single phase AC 230V with capacitor	▲	▲			
	Driver for converter operation incl. posistor, 5-100 Hz	▲	▲			
Driver for converter operation II2G EExde IICT4, 5-100 Hz gem. ATEX 95, incl. integrated posistor	▲	▲				
		● = Basic design	○ = without add. price	▲ = with add. price	-- = not available	Art.-Nr. = available in basic design/accessories

Order information

Basic design

R409.1-...K.1

- Pump body 1.4122 V
- Piston 1.4571
- Valve balls 1.4401
- Valve seals FPM
- Piston seal V-seal made of PTFE/PE
- Protective diaphragm made of CR (Neoprene)
- Double Valves made of 1.4571/1.4581

Further options and accessories



- Connection pieces see chapter 4
- Product documentation see chapter 5

Type	Basic design	x
R409.1-7K.1/14	16002690	
R409.1-8,5K.1/14	16002493	
R409.1-11K.1/14	16003856	
R409.1-13K.1/14	16000021	
R409.1-14K.1/20	16000801	
R409.1-17K.1/20	16001076	
R409.1-22K.1/20	16000880	
R409.1-26K.1/20	16000804	
R409.1-28K.1/28	16000805	
R409.1-34K.1/28	16000806	
R409.1-44K.1/28	16000807	
R409.1-52K.1/28	16001998	

Motor:

- 200-254/346-440 V 50 Hz / 200-280/346-480 V 60 Hz Drehstrom, IP 55, ISO F

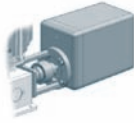
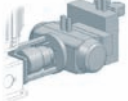
2

Options/Accessories		R409.1-7K.1/14 R409.1-11K.1/14 R409.1-14K.1/20 R409.1-22K.1/28 R409.1-28K.1/28 R409.1-44K.1/28	x	R409.1-8,5K.1/14 R409.1-13K.1/14 R409.1-17K.1/20 R409.1-26K.1/20 R409.1-34K.1/28 R409.1-52K.1/28	x	
Stroke length adjustment electrical 	Actuator N C1-BA 230 V, +/- 10%, 50/60 Hz, 128s/10 U, 1,5 Nm incl. mounting plate for actuator	▲		▲		
	Electronic positioning controller PMR3 input signal 0/4-20 mA incl. feedback signal 0/4-20 mA (only in N C1-BA integrated)	▲		▲		
	Actuator D30D-10-Ex (II2G EExde IICT4) acc. to ATEX 95, 400 V, 50 Hz, 10 U/min, incl. mounting-kit for actuator and base plate	▲		▲		
Stroke length adjustment pneumatical 	Actuator WPD-4P-60 positioning controller CT 720 control air 6 bar, intake air pressure 3-10 bar IP 65, incl. mounting kit for actuator	▲		▲		
Stroke frequency adjustment electrical 	Frequency converter series 8200 Motec mounted-on, input 4-20mA					
	Single-phase 230 V, 50/60 Hz	0.25 kW	▲		-	
		0.37 kW	-		▲	
	Three-phase 320-550 V, +/- 0%, 50/60 Hz	0.55 kW	▲		▲	
	Switch-potentiometer for manual stroke frequency adjustment and to switch on the pump motor (External control of the frequency converter with mounted switch potentiometer unit is not possible)		▲		▲	
	Service module hand terminal and keypad incl. 2,5m connection cable		▲		▲	
<p>● = Basic design ○ = without add. price ▲ = with add. price - = not available Art.-Nr. = available in basic design/accessories</p>						

Order information

Basic design

R409.1-...K.1

- Pump body 1.4122 V
- Piston 1.4571
- Valve balls 1.4401
- Valve seals FPM
- Piston seal V-seal made of PTFE/PE
- Protective diaphragm made of CR (Neoprene)
- Double Valves made of 1.4571/1.4581

Motor:

- 200-254/346-440 V 50 Hz / 200-280/346-480 V 60 Hz Drehstrom, IP 55, ISO F

Further options and accessories

- Connection pieces see chapter 4
- Product documentation see chapter 5

Type	Basic design	x
R409.1-7K.1/14	16002690	
R409.1-8,5K.1/14	16002493	
R409.1-11K.1/14	16003856	
R409.1-13K.1/14	16000021	
R409.1-14K.1/20	16000801	
R409.1-17K.1/20	16001076	
R409.1-22K.1/20	16000880	
R409.1-26K.1/20	16000804	
R409.1-28K.1/28	16000805	
R409.1-34K.1/28	16000806	
R409.1-44K.1/28	16000807	
R409.1-52K.1/28	16001998	

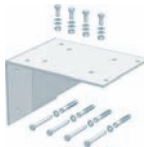
Options/Accessories		R409.1-7K.1/14 R409.1-11K.1/14 R409.1-14K.1/20 R409.1-22K.1/28 R409.1-28K.1/28 R409.1-44K.1/28	R409.1-8,5K.1/14 R409.1-13K.1/14 R409.1-17K.1/20 R409.1-26K.1/20 R409.1-34K.1/28 R409.1-52K.1/28
Stroke frequency adjustment electrical	Frequency converter series 8200 Vector input 4-20mA, incl. Keypad (for integration into control cabinet)		
	Single-phase 230 V, 50/60 Hz	0.25 kW 90017521	– 90017522
		0.37 kW –	
	Three-phase 320-550 V, +/- 0%, 50/60 Hz	0.55 kW 90017526	90017526
Console			
	for wall mounting incl. fixing screws	1.4301 90023875	90023875
		PP 90023848	90023848
<p>● = Basic design ○ = without add. price ▲ = with add. price – = not available Art.-Nr. = available in basic design/accessories</p>			

Fittings for suction side of dosing pumps			R409.1-7K.1/14 up to R409.1-14K.1/20		R409.1-17K.1/20 up to R409.1-52K.1/28	
			Type	p.	Type	p.
Suction lance	with level switch 1-stage	SL-02	3.34	SL-02	3.34	
		S-03	3.38	S-03	3.38	
	with level switch 2-stage without level switch	SL-02	3.34	SL-02	3.34	
		S-01	3.42	S-01	3.42	
Suction aid / Siphon Vessel	transparent PVC-U	770.2	3.74	770.2	3.74	
Calibration Pot	PVC-U	791.1	3.76	792.1	3.76	
Foot valve	1.4571	731	3.78	731	3.78	
Line strainer	1.4408	752	3.86	752	3.86	
Float valve	PVC-U	871	3.88	871	3.88	
Pulsation damper without separating diaphragm	1.4571	802.1	3.18	802.1	3.18	
Fittings for pressure side of dosing pumps			R409.1-7K.1/14 up to R409.1-14K.1/20		R409.1-17K.1/20 up to R409.1-52K.1/28	
			Type	p.	Type	p.
Pulsation damper without separating diaphragm	1.4571	802.1	3.18	802.1	3.18	
Diaphragm-pulsation damper with PTFE/PTFE-faced diaphragm	1.4571	721.1	3.28	721.1	3.28	
Diaphragm-pulsation damper with Elastomer-diaphragm	1.4571	810.1-0,16/180	3.30	810.1-0,16/180	3.30	
Check valve	1.4571	661.2	3.48	661.2	3.48	
Dosing valve	1.4571	691.1	3.54	691.1	3.54	

The above allocation considers the fittings which have to be used at least regarding their nominal width in order to ensure the safe and trouble-free operation of the respective pumps when feeding liquids which are resembling to water.

Absolutely note the max. admissible operating pressure of the fittings.

The use of fittings of a bigger nominal width is unproblematically possible in most cases.

When choosing the fittings note the installation instructions for dosing pumps or confer with s e r a.

2

Piston pumps

Flow capacity 0,4 l/h ... 2.4 l/h

Admissible counterpressure up to 100 bar



R408.1-...P/...

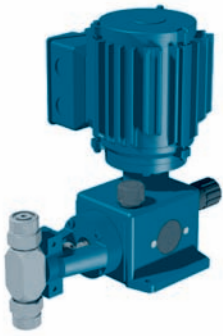

R408.1-...P/... in survey

- Compact design
- Low maintenance
- High dosing accuracy
- High quality materials
- User-friendly
- Integrateable into automatic processes
- Manual stroke length adjustment
- Robust metallic stroke mechanism housing

Infobox

Order information	Page 2.127
Options/accessories	Page 2.127
fittings-allocation	Page 2.129
connecting pieces	Chapter 4
resistance chart	Chapter 5
installation examples	Chapter 5

Technical data

Type	Nominal capacity		Nominal stroke frequency		Admissible counter-pressure	Max. suction height	Inlet/ Outlet nominal width	Max. stroke length	Motor output
	l/h		1/min						
	50 Hz	60 Hz	50 Hz	60 Hz					
R408.1-0,4P/6	0 - 0.4	0 - 0.48	80	96	100	afflux	5	4	0.09
R408.1-0,8P/6	0 - 0.8	0 - 0.8	156	160	100	afflux	5	4	0.09
R408.1-1,2P/6	0 - 1.2	0 - 1.2	156	160	100	afflux	5	6	0.09
R408.1-1,6P/8	0 - 1.6	0 - 1.6	156	160	100	afflux	5	4	0.09
R408.1-2,4P/8	0 - 2.4	0 - 2.4	156	160	100	afflux	5	6	0.09

Dimensional drawing

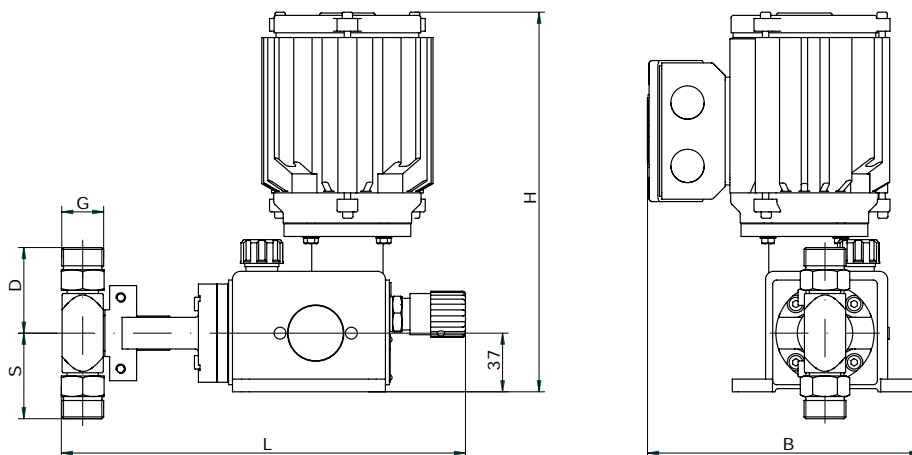

Dimensional chart

All indications in mm

Type	G	S	D	L	B	H	Weight kg
R408.1-0,4P/6	G 3/4	54	54	252	165	275	8.8
R408.1-0,8P/6	G 3/4	54	54	252	165	275	8.8
R408.1-1,2P/6	G 3/4	54	54	252	165	275	8.8
R408.1-1,6P/8	G 3/4	54	54	252	165	275	8.9
R408.1-2,4P/8	G 3/4	54	54	252	165	275	8.9

Indication of weight for Basic design acc. to order information

Order information

Basic design

R408.1-...P

- Pump body 1.4581
- Chamber valves 1.4571
- Valve balls 1.4401
- Piston 1.4571 / oxide ceramic-faced
- Valve seals FPM
- Piston seal PTFE/PE





Further options and accessories

- Connection pieces see chapter 4
- Product documentation see chapter 5

Type	Basic design	x
R408.1-0,4P/6	16001351	
R408.1-0,8P/6	16003628	
R408.1-1,2P/6	16000576	
R408.1-1,6P/8	16003825	
R408.1-2,4P/8	16001600	

Motor:

- 200-254/346-440 V 50 Hz / 200-280/346-480 V 60 Hz threephase, IP 55, insul.cl. F

Options/Accessories		R408.1-0,4P/6 up to R408.1-2,4P/8	x
Valve sealings 	FPM	●	
	EPDM	○	
	FEP-covered	▲	
Stroke length adjustment 	with position indicator	▲	
Stroke frequency monitoring 	Inductive contact		
	10-60 V DC, three-wire, PNP	▲	
	Namur execution, II2G EExia IICT6 acc. to ATEX95	▲	
Drive motor 	Special voltage	▲	
	Enclosure IP 65	▲	
	Integrated posistor (3 pcs.) insul. cl. F	▲	
	VIK-design	▲	
	II2G EExe IIT4 (acc. to ATEX95)	▲	
	II2G EExde IICT4 (acc. to ATEX95)	▲	
	Single phase AC 230V with capacitor	▲	
	Driver for converter operation incl. posistor, 5-100 Hz	▲	
Stroke length adjustment electrical 	Driver for converter operation II2G EExde IICT4, 5-100 Hz gem. ATEX 95, incl. integrated posistor	▲	
	Actuator N C1-BA 230 V, +/- 10%, 50/60 Hz, 128s/10 U, 1,5 Nm incl. mounting plate for actuator	▲	
	Electronic positioning controller PMR3 input signal 0/4-20 mA incl. feedback signal 0/4-20 mA (only in N C1-BA integrated)	▲	
	Actuator D30D-10-Ex (II2G EExde IICT4) acc. to ATEX 95, 400 V, 50 Hz, 10 U/min, incl. mounting-kit for actuator and base plate	▲	
<p style="text-align: center;">● = Basic design ○ = without add. price ▲ = with add. price Art.-Nr. = available in basic design/ accessories</p>			

Piston pumps

Flow capacity 0,4 l/h ... 2.4 l/h

Admissible counterpressure up to 100 bar



R408.1-...P/...

Order information

Basic design

R408.1-...P

- Pump body 1.4581
- Chamber valves 1.4571
- Valve balls 1.4401
- Piston 1.4571 / oxide ceramic-faced
- Valve seals FPM
- Piston seal PTFE/PE

Further options and accessories



- Connection pieces see chapter 4
- Product documentation see chapter 5

Type	Basic design	x
R408.1-0,4P/6	16001351	
R408.1-0,8P/6	16003628	
R408.1-1,2P/6	16000576	
R408.1-1,6P/8	16003825	
R408.1-2,4P/8	16001600	

Motor:

- 200-254/346-440 V 50 Hz / 200-280/346-480 V 60 Hz threephase, IP 55, insul.cl. F

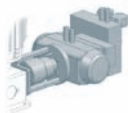
2

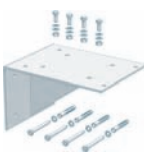
Options/Accessories		R408.1-0,4P/6 up to R408.1-2,4P/8		x
Stroke length adjustment pneumatical 	Actuator WPD-4P-60 positioning controller CT 720 control air 6 bar, intake air pressure 3-10 bar IP 65, incl. mounting kit for actuator		▲	
	Stroke frequency adjustment electrical Frequency converter series 8200 Motec mounted-on, input 4-20mA			
	Single-phase 230 V, 50/60 Hz	0.25 kW	▲	
	Three-phase 320-550 V, +/- 0%, 50/60 Hz	0.55 kW	▲	
	Switch-potentiometer for manual stroke frequency adjustment and to switch on the pump motor (External control of the frequency converter with mounted switch potentiometer unit is not possible)		▲	
	Service module hand terminal and keypad incl. 2,5m connection cable		▲	
Stroke frequency adjustment electrical 	Frequency converter series 8200 Vector input 4-20mA, incl. Keypad (for integration into control cabinet)			
	Single-phase 230 V, 50/60 Hz	0.25 kW	90017521	
	Three-phase 320-550 V, +/- 0%, 50/60 Hz	0.55 kW	90017526	
Console 	PP for wall mounting incl. fixing screws		90023845	
	1.4301		90023872	
● = Basic design ○ = without add. price ▲ = with add. price		Art.-Nr. = available in basic design/ accessories		

Fittings for suction side of dosing pumps		R408.1-0,4P/6 up to R408.1-2,4P/8	
		Type	p.
Calibration Pot	PVC-U	791.1	3.76
	PVC-U	731	3.78
Foot valve	PP-FRP / PVDF-FRP	781.1	3.82
	1.4571	731	3.78
Line strainer	PVC-U	751.1	3.84
	PVC-U / PP / PVDF	752.1	3.84
	1.4408	752	3.86
Float valve	PVC-U	871	3.88
Fittings for pressure side of dosing pumps		R408.1-0,4P/6 up to R408.1-2,4P/8	
		Type	p.
Diaphragm-pulsation damper with PTFE/PTFE-faced diaphragm	1.4571	721.1	3.28
Diaphragm-pulsation damper with Elastomer-diaphragm	1.4571	810.1-0,16/180	3.30
Check valve	1.4571	661.2	3.48
Dosing valve	1.4571	691.1	3.54

The above allocation considers the fittings which have to be used at least regarding their nominal width in order to ensure the safe and trouble-free operation of the respective pumps when feeding liquids which are resembling to water.

Absolutely note the max. admissible operating pressure of the fittings.

The use of fittings of a bigger nominal width is unproblematically possible in most cases.

When choosing the fittings note the installation instructions for dosing pumps or confer with s e r a.



409.1-...ML in survey

- Compact design
- Multilayer-diaphragm technology
- Safe if run dry
- Low-maintenance
- User-friendly
- High dosing accuracy
- Integrateable into automatic processes
- Manual stroke length adjustment
- Robust metallic stroke mechanism housing

Infobox

- order information [Page 2.131](#)
- options/accessories [Page 2.131](#)
- fittings-allocation [Page 2.134](#)
- connecting pieces [Chapter 4](#)
- resistance chart [Chapter 5](#)
- installation examples [Chapter 5](#)

Technical data

Type	Nominal capacity		Nominal stroke frequency		Admissible counter pressure bar	Admissible pressure at pump inlet bar	Max. suction height mWS	Inlet/Outlet nominal width DN	Max. stroke length mm	Motor output kW
	50 Hz	60 Hz	50 Hz	60 Hz						
R409.1-9,0ML	0 - 9	0 - 11	80	96	20	-0.3 / 0	3	10	4	0.37
R409.1-17ML	0 - 17	–	150	–	20	-0.3 / 0	3	10	4	0.37
R409.1-24ML	0 - 24	0 - 28	80	96	16	-0.3 / 0	3	10	6	0.37
R409.1-45ML	0 - 45	–	150	–	16	-0.3 / 0	3	10	6	0.37
R409.1-60ML	0 - 60	0 - 70	80	96	10	-0.3 / 0	3	15	8	0.37
R409.1-115ML	0 - 115	–	150	–	10	-0.3 / 0	3	15	8	0.37
R409.1-120ML	0 - 120	0 - 145	80	96	4	-0.3 / 0	3	15	10	0.37
R409.1-220ML	0 - 220	–	150	–	4	-0.3 / 0	3	15	10	0.37

Note: The admissible counterpressure is 10 bar or lower when plastic pump bodies are used.

Dimensional drawing

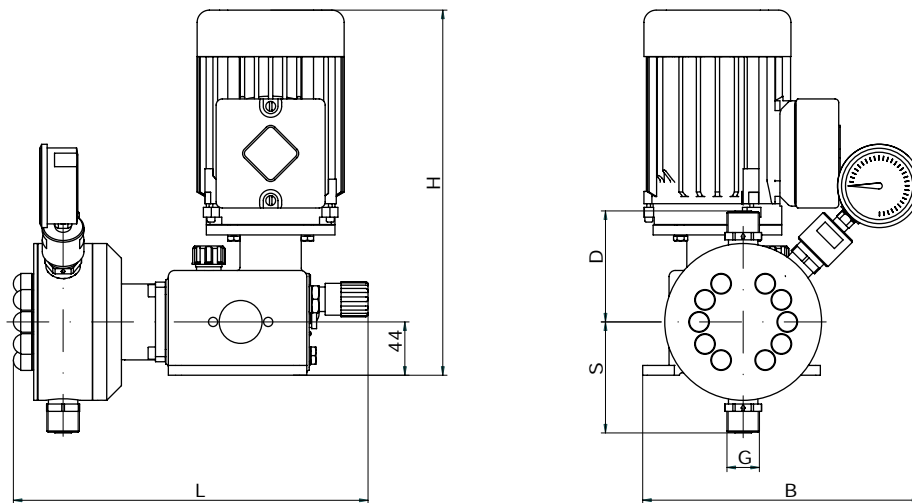

Dimensional chart

All indications in mm

Type	G	S	D	L	B	H	Weight kg
R409.1-9,0ML	G 3/4	83	83	296	173	298	17,5
R409.1-17ML	G 3/4	83	83	296	173	298	17,5
R409.1-24ML	G 3/4	90	90	296	173	298	18
R409.1-45ML	G 3/4	90	90	296	173	298	18
R409.1-60ML	G 3/4	94	94	302	173	298	18,5
R409.1-115ML	G 3/4	94	94	302	173	298	18,5
R409.1-120ML	G 1 1/4	156	156	327	173	298	20,5
R409.1-220ML	G 1 1/4	156	156	327	173	298	20,5

Indication of weight for basis design acc. to order information

Order information

Basic design

409.1-...ML

- Pump body PP
- Double valves PP-FRP
- Valve balls glass
- Valve seals FPM
- Working diaphragm PTFE
- Optical diaphragm rupture indicator with manometer





Motor:

- 200-254/346-440 V 50 Hz / 200-280/346-480 V 60 Hz threephase, IP 55, insul. cl. F

Further options and accessories:

- Connection pieces see chapter 4
- Product documentation see chapter 5

Type	Basic design	x
R409.1-9,0ML	16003815	
R409.1-17ML	15001136	
R409.1-24ML	16003871	
R409.1-45ML	15001135	
R409.1-60ML	16001941	
R409.1-115ML	16003839	
R409.1-120ML	16004491	
R409.1-220ML	16003840	

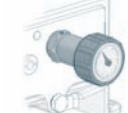
Options/Accessories			R409.1-9,0ML R409.1-17ML	x	R409.1-24ML up to R409.1-60ML	x	R409.1-115ML	x	R409.1-120ML R409.1-220ML	x	
Pump body and valves 	PP	double valves PP-FRP	●		●		●		●		
		single valves PVC-U	-		▲		▲		▲		
	PVC-U	chamber valves (double valves) PVC-U	▲		-		-		-		
		PVDF	double valves PVDF-FRP	⊙		▲		▲		▲	
	1.4571	single valves 1.4571/1.4581	-		-		-		▲		
		double valves 1.4571/1.4581	-		▲		▲		▲		
chamber valves (double valves) 1.4571		▲		-		-		-			
Valve balls 	Glass	single valves	-		○		○		○		
		double valves	●		●		●		●		
	1.4401	single valves	-		○		○		▲		
		double valves	○		○		○		▲		
	PTFE	single valves	-		▲		▲		▲		
		double valves	▲		▲		▲		▲		
Valve sealings 	FPM	single valves	-		○		○		○		
		double valves	●		●		●		●		
	EPDM	single valves	-		○		○		○		
		double valves	○		○		○		○		
	FEP-covered	single valves	-		▲		▲		▲		
		double valves	▲		▲		▲		▲		
Diaphragm rupture monitoring 	Optical diaphragm rupture indicator with manometer		●		●		●		●		
	Pressure switch IP 65		▲		▲		▲		▲		
	Pressure switch II2G EExd IIC T5 or T6 acc. to ATEX95		▲		▲		▲		▲		
Stroke length adjustment 	with position indicator		▲		▲		▲		▲		
● = Basic design ▲ = with add. price ○ = without add. price - = not available ⊙ = on request Art.-Nr. = available in basic design/accessories											

Order information

Basic design

R 409.1-...ML

- Pump body PP
- Double valves PP-FRP
- Valve balls glass
- Valve seals FPM
- Working diaphragm PTFE
- optical diaphragm rupture indicator with manometer





Motor:

- 200-254/346-440 V 50 Hz / 200-280/346-480 V 60 Hz threephase, IP 55, insul. cl. F

Further options and accessories:

- Connection pieces see chapter 4
- Product documentation see chapter 5

Type	Basic design	x
R409.1-9,0ML	16003815	
R409.1-17ML	15001136	
R409.1-24ML	16003871	
R409.1-45ML	15001135	
R409.1-60ML	16001941	
R409.1-115ML	16003839	
R409.1-120ML	16004491	
R409.1-220ML	16003840	

Options/Accessories		R409.1-9,0ML R409.1-17ML x	R409.1-24ML up to R409.1-60ML x	R409.1-115ML x	R409.1-120ML R409.1-220ML x
Stroke frequency monitoring 	Inductive contact				
	10-60 V DC, three-wire, PNP	▲	▲	▲	▲
Drive motor 	Namur execution, II2G EExia IICT6 acc. to ATEX95	▲	▲	▲	▲
	Special voltage	▲	▲	▲	▲
	Enclosure IP 65	▲	▲	▲	▲
	Protective roof for the fan of the drive	▲	▲	▲	▲
	Integrated posistor (3 pcs.) insul. cl. F	▲	▲	▲	▲
	VIK-design	▲	▲	▲	▲
	II2G EExe IIT4 (acc. to ATEX95)	▲	▲	▲	▲
	II2G EExde IICT4 (acc. to ATEX95)	▲	▲	▲	▲
	Single phase AC 230V with capacitor	▲	▲	▲	▲
	Driver for converter operation incl. integrated posistor, 5-50/60Hz	▲	▲	▲	▲
Driver for converter operation II2G EExde IICT4, 5-50/60 Hz gem. ATEX 95, incl. integrated posistor	▲	▲	▲	▲	
Stroke length adjustment electrical 	Actuator N C1-BA 230 V, +/- 10%, 50/60 Hz, 128s/10 U, 1,5 Nm incl. mounting plate for actuator	▲	▲	▲	▲
	Electronic positioning controller PMR3 input signal 0/4-20 mA incl. feedback signal 0/4-20 mA (only in N C1-BA integrated)	▲	▲	▲	▲
	Actuator D30D-10-Ex (II2G EExde IICT4) acc. to ATEX 95, 400 V, 50 Hz, 10 U/min, incl. mounting-kit for actuator and base plate	▲	▲	▲	▲
Stroke length adjustment pneumatical 	Actuator WPD-4P-60 positioning controller CT 720 control air 6 bar, intake air pressure 3-10 bar IP 65, incl. mounting kit for actuator	▲	▲	▲	▲
● = Basic design ▲ = with add. price ○ = without add. price – = not available ⊕ = on request Art.-Nr. = available in basic design/accessories					

Order information

Basic design

R409.1-...ML

- Pump body PP
- Double valves PP-FRP
- Valve balls glass
- Valve seals FPM
- Working diaphragm PTFE
- optical diaphragm rupture indicator with manometer



Motor:

- 200-254/346-440 V 50 Hz / 200-280/346-480 V 60 Hz three-phase, IP 55, insul. cl. F

Further options and accessories:

- Connection pieces see chapter 4
- Product documentation see chapter 5

Type	Basic design	x
R409.1-9,0ML	16003815	
R409.1-17ML	15001136	
R409.1-24ML	16003871	
R409.1-45ML	15001135	
R409.1-60ML	16001941	
R409.1-115ML	16003839	
R409.1-120ML	16004491	
R409.1-220ML	16003840	

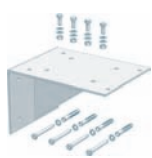
Options/Accessories		R409.1-9,0ML R409.1-17ML	x	R409.1-24ML up to R409.1-60ML	x	R409.1-115ML	x	R409.1-120ML R409.1-220ML	x
Stroke frequency adjustment electrical 	Frequency converter series 8200 Motec mounted-on, input 4-20mA								
	Single-phase 230 V, 50/60 Hz 0.37 kW	▲		▲		▲		▲	
	Three-phase 320-550 V, +/- 0%, 50/60 Hz 0.37 kW	▲		▲		▲		▲	
	Switch-potentiometer for manual stroke frequency adjustment and to switch on the pump motor (External control of the frequency converter with mounted switch potentiometer unit is not possible)	▲		▲		▲		▲	
	Service module hand terminal and keypad incl. 2,5m connection cable	▲		▲		▲		▲	
Stroke frequency adjustment electrical 	Frequency converter series 8200 Vector input 4-20mA, incl. Keypad (for integration into control cabinet)								
	Single-phase 230 V, 50/60 Hz 0.37 kW	90017522		90017522		90017522		90017522	
	Three-phase 320-550 V, +/- 0%, 50/60 Hz 0.55 kW	90017526		90017526		90017526		90017526	
Console 	1.4301 for wall mounting incl. fixing screws	90023875		90023875		90023875		90023875	
	PP	90023848		90023848		90023848		90023848	
● = Basic design ▲ = with add. price ○ = without add. price -- = not available ⊕ = on request Art.-Nr. = available in basic design/accessories									

Multi-layer diaphragm pumps

Flow capacity 9 l/h ... 220 l/h

Admissible counterpressure up to 20 bar



R409.1-...ML

Fittings for suction side of dosing pumps		R409.1-9,0ML bis R409.1-24ML		R409.1-45ML		R409.1-60ML		R409.1-115ML		R409.1-120ML		R409.1-220ML	
		type	p.	type	p.	type	p.	type	p.	type	p.	type	p.
Suction lance	with level switch 1-stage	SL-11.1	3.36	SL-02	3.34	SL-02	3.34	SL-02	3.34	SL-02	3.34	S-04	3.40
		⊗		S-03	3.38	S-03	3.38	S-03	3.38	S-03	3.38	⊗	
	without level switch	SL-12.1	3.36	SL-02	3.34	SL-02	3.34	SL-02	3.34	SL-02	3.34	⊗	
Suction aid / Siphon Vessel	transparent PVC-U	770.2	3.74	770.2	3.74	770.2	3.74	770.2	3.74	770.2	3.74	770.2	3.74
Calibration Pot	PVC-U	792.1	3.76	792.1	3.76	793.1	3.76	793.1	3.76	793.1	3.76	794.1	3.76
Foot valve	PVC-U	731	3.78	731	3.78	731	3.78	732.2	3.80	732.2	3.80	732.2	3.80
	PP / PVDF	⊗		⊗		⊗		732	3.78	732	3.78	732	3.78
	PP-FRP / PVDF-FRP	781.1	3.82	781.1	3.82	781.1	3.82	⊗		⊗		783.1	3.82
	1.4571	731	3.78	731	3.78	731	3.78	732	3.78	732	3.78	732	3.78
Line strainer	PVC-U	751.1	3.84	751.1	3.84	751.1	3.84	751.1	3.84	751.1	3.84	⊗	
	PVC-U / PP / PVDF	752.1	3.84	752.1	3.84	752.1	3.84	752.1	3.84	752.1	3.84	752.1	3.84
	1.4408	752	3.86	752	3.86	752	3.86	752	3.86	752	3.86	752	3.86
Float valve	PVC-U	871	3.88	871	3.88	871	3.88	871	3.88	871	3.88	872	3.88
Pulsation damper without separating diaphragm	PVC-U / PP	702.1	3.14	702.1	3.14	702.1	3.14	702.1	3.14	702.1	3.14	702.1	3.14
	1.4571	802.1	3.18	802.1	3.18	802.1	3.18	802.1	3.18	802.1	3.18	802.1	3.18
Fittings for pressure side of dosing pumps		R409.1-9,0ML bis R409.1-24ML		R409.1-45ML		R409.1-60ML		R409.1-115ML		R409.1-120ML		R409.1-220ML	
		type	p.	type	p.	type	p.	type	p.	type	p.	type	p.
Diaphragm-type relief valve		620.10	3.4	620.10	3.4	620.10	3.4	622.10	3.4	622.10	3.4	622.10	3.4
Diaphragm-type pressure keeping valve		620.D	3.8	620.D	3.8	620.D	3.8	622.D	3.8	622.D	3.8	622.D	3.8
Multi-function valve	4 bar opening pressure	MFV 05004	3.10	MFV 05004	3.10	-		-		-		-	
	6 bar opening pressure	MFV 05006	3.10	MFV 05006	3.10	-		-		-		-	
	10 bar opening pressure	MFV 05010	3.10	MFV 05010	3.10	-		-		-		-	
Pulsation damper without separating diaphragm	PVC-U / PP	702.1	3.14	702.1	3.14	702.1	3.14	702.1	3.14	702.1	3.14	702.1	3.14
	1.4571	802.1	3.18	802.1	3.18	802.1	3.18	802.1	3.18	802.1	3.18	802.1	3.18
Diaphragm-pulsation damper with PTFE/PTFE-faced diaphragm	PVC-U / PP / PVDF	720.1	3.24	721.2	3.24	721.2	3.24	722.1	3.24	722.1	3.24	722.1	3.24
	1.4571	721.1	3.28	721.1	3.28	721.1	3.28	722.1	3.28	722.1	3.28	722.1	3.28
Diaphragm-pulsation damper with Elastomer-diaphragm	1.4571	810.1-0,16/180	3.30	810.1-0,16/180	3.30	810.1-0,16/180	3.30	810.1-0,32/160	3.30	810.1-0,32/160	3.30	810.1-0,75/140	3.30
Check valve	PP-FRP / PVDF-FRP	661.2	3.48	661.2	3.48	661.2	3.48	661.2	3.48	663.2	3.48	663.2	3.48
	PVC-U	661.2	3.48	661.2	3.48	661.2	3.48	661.2	3.48	⊗		⊗	
	1.4571	661.2	3.48	661.2	3.48	661.2	3.48	661.2	3.48	662.2	3.48	662.2	3.48
Dosing valve	PVC-U	691.1	3.54	691.1	3.54	691.1	3.54	691.1	3.54	⊗		⊗	
	PVC-U / PP / PVDF	681.1	3.58	681.1	3.58	681.1	3.58	681.1	3.58	682.1	3.58	682.1	3.58
	PP-FRP / PVDF-FRP	691.1	3.54	691.1	3.54	691.1	3.54	691.1	3.54	693.1	3.54	693.1	3.54
	1.4571	691.1	3.54	691.1	3.54	691.1	3.54	691.1	3.54	692.1	3.54	692.1	3.54
Injection fitting	PVC-U / PP / PVDF	8061.1	3.60	8061.1	3.60	8061.1	3.60	8061.1	3.60	8062.1	3.60	8062.1	3.60

⊗ = on request

- = not available

The above allocation considers the fittings which have to be used at least regarding their nominal width in order to ensure the safe and trouble-free operation of the respective pumps when feeding liquids which are resembling to water. Absolutely note the max. admissible operating pressure of the fittings.

The use of fittings of a bigger nominal width is unproblematically possible in most cases.

When choosing the fittings note the installation instructions for dosing pumps or confer with s e r a.

Multi-layer diaphragm pumps

Flow capacity 60 l/h ... 600 l/h

Admissible counterpressure up to 16 bar



R411.1-...ML



411.1-...ML in survey

- Compact design
- Multilayer-diaphragm technology
- Safe if run dry
- Low-maintenance
- User-friendly
- High dosing accuracy
- Integrateable into automatic processes
- Manual stroke length adjustment
- Robust metallic stroke mechanism housing

Infobox

- order information [Page 2.137](#)
- options/accessories [Page 2.137](#)
- fittings-allocation [Page 2.140](#)
- connecting pieces [Chapter 4](#)
- resistance chart [Chapter 5](#)
- installation examples [Chapter 5](#)

Technical data

Type	Nominal capacity		Nominal stroke frequency		Admissible counter-pressure	Admissible pressure at pump inlet	Max. suction height	Inlet/Outlet nominal width	Max. stroke length	Motor output
	l/h		1/min							
	50 Hz	60 Hz	50 Hz	60 Hz						
R411.1-60ML	0 - 60	0 - 70	76	92	16	-0.3 / 0	3	10	8	0.75
R411.1-75ML	0 - 75	0 - 90	97	116	16	-0.3 / 0	3	15	8	0.75
R411.1-105ML	0 - 105	0 - 125	76	92	15	-0.3 / 0	3	15	10	0.75
R411.1-135ML	0 - 135	0 - 160	97	116	15	-0.3 / 0	3	15	10	0.75
R411.1-400ML	0 - 400	0 - 480	76	92	10	-0.3 / 0	3	15	13	0.75
R411.1-500ML	0 - 500	0 - 600	97	116	10	-0.3 / 0	3	15	13	0.75

Note: The admissible counterpressure is 10 bar or lower when plastic pump bodies are used.

Dimensional drawing

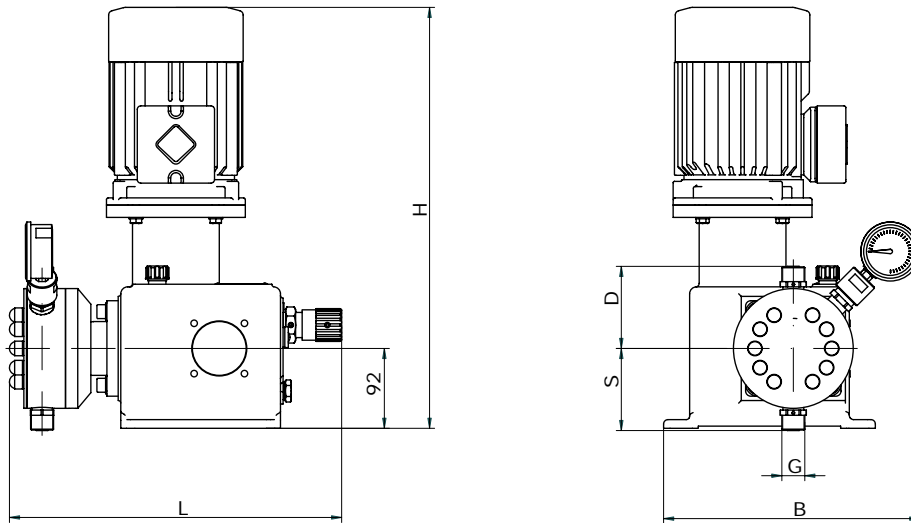

Dimensional chart

All indications in mm

Type	G	S	D	L	B	H	Weight kg
R411.1-60ML	G 3/4	94	94	395	244	486	43,5
R411.1-75ML	G 3/4	94	94	395	244	486	43,5
R411.1-105ML	G 1 1/4	156	156	420	244	486	46
R411.1-135ML	G 1 1/4	156	156	420	244	486	46
R411.1-400ML	G 1 1/4	167	167	437	244	486	48,5
R411.1-500ML	G 1 1/4	167	167	437	244	486	48,5

Indication of weight for basis design acc. to order information

Order information

Basic design

Types 411.1-...ML:

- Pump body PP
- Double valve PP-FRP
- Valve balls glass
- Valve seals FPM
- Working diaphragm PTFE
- Optical diaphragm rupture indicator with manometer







Further options and accessories:

- Connection pieces see chapter 4
- Product documentation see chapter 5

Type	Basic design	x
R411.1-60ML	16004561	
R411.1-75ML	16004560	
R411.1-105ML	16004518	
R411.1-135ML	16004521	
R411.1-400ML	16004008	
R411.1-500ML	16003826	

Motor:

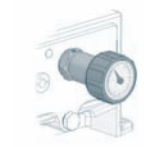
- 200-254/346-440 V 50 Hz / 200-280/346-480 V 60 Hz threephase, IP 55, insul. cl. F

Options/Accessories			R411.1-60ML R411.1-75ML	x	R411.1-105ML R411.1-135ML	x	R411.1-400ML R411.1-500ML	x
Pump body and valves 	PP	double valves PP-FRP	●		●		●	
	PVC-U	single valves PVC-U	▲		▲		▲	
	PVDF	double valves PVDF-FRP	▲		▲		▲	
	1.4571	single valves 1.4571/1.4581	-		▲		▲	
double valves 1.4571/1.4581		▲		▲		▲		
Valve balls 	Glass	single valves	○		○		○	
		double valves	●		●		●	
	1.4401	single valves	○		▲		▲	
		double valves	○		▲		▲	
PTFE	single valves	▲		▲		▲		
	double valves	▲		▲		▲		
Valve sealings 	FPM	single valves	○		○		○	
		double valves	●		●		●	
	EPDM	single/double valves	○		○		○	
		FEP-covered	single valves	▲		▲		▲
double valves	▲			▲		▲		
Diaphragm rupture monitoring 	Optical diaphragm rupture indicator with manometer		●		●		●	
	Pressure switch IP 65		▲		▲		▲	
	Pressure switch II2G EExd IIC T5 or T6 acc. to ATEX95		▲		▲		▲	
Stroke length adjustment 	with position indicator		▲		▲		▲	
Stroke frequency monitoring 	Inductive contact							
	10-60 V DC, three-wire, PNP		▲		▲		▲	
	Namur execution, II2G EExia IIC T6 acc. to ATEX95		▲		▲		▲	

● = Basic design ▲ = with add. pricer - = not available ○ = without add. price Art.-Nr. = available in basic design/accessories

Order information

Basic design

Types 411.1-...ML:

- Pump body PP
- Double valve PP-FRP
- Valve balls glass
- Valve seals FPM
- Working diaphragm PTFE
- Optical diaphragm rupture indicator with manometer

Further options and accessories:

- Connection pieces see chapter 4
- Product documentation see chapter 5

Type	Basic design	x
R411.1-60ML	16004561	
R411.1-75ML	16004560	
R411.1-105ML	16004518	
R411.1-135ML	16004521	
R411.1-400ML	16004008	
R411.1-500ML	16003826	

Motor:

- 200-254/346-440 V 50 Hz / 200-280/346-480 V 60 Hz threephase, IP 55, insul. cl. F

2

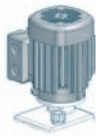
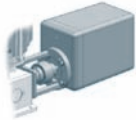
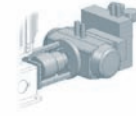
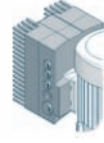
Options/Accessories		R411.1-60ML R411.1-75ML	x	R411.1-105ML R411.1-135ML	x	R411.1-400ML R411.1-500ML	x
Drive motor 	Special voltage	▲		▲		▲	
	Enclosure IP 65	▲		▲		▲	
	Protective roof for the fan of the drive	▲		▲		▲	
	Integrated posistor (3 pcs.) insul. cl. F	▲		▲		▲	
	VIK-design	▲		▲		▲	
	II2G EExe IIT4 (acc. to ATEX95)	▲		▲		▲	
	II2G EExde ICT4 (acc. to ATEX95)	▲		▲		▲	
	Single phase AC 230V with capacitor	▲		▲		▲	
	Driver for converter operation incl. integrated posistor, 5-50/60Hz	▲		▲		▲	
Driver for converter operation II2G EExde ICT4, 5-50/60 Hz gem. ATEX 95, incl. integrated posistor	▲		▲		▲		
Stroke length adjustment electrical 	Actuator N1S 230 V, 50/60 Hz, 128s/10 U, 15 Nm Potentiometer 1 kOhm incl. mounting kit for actuator	▲		▲		▲	
	Electronic positioning controller PMR3 input signal 0/4-20 mA incl. feedback signal 0/4-20 mA (only in N 1S integrated)	▲		▲		▲	
	Actuator D30D-10-Ex (II2G EExde ICT4) acc. to ATEX 95, 400 V, 50 Hz, 10 U/min, incl. mounting-kit for actuator and base plate	▲		▲		▲	
Stroke length adjustment pneumatical 	Actuator WPD-4P-60 positioning controller CT 720 control air 6 bar, intake air pressure 3-10 bar IP 65, incl. mounting kit for actuator	▲		▲		▲	
Stroke frequency adjustment electrical 	Frequency converter series 8200 Motec mounted-on, input 4-20mA						
	Three-phase 320-550 V, +/- 0%, 0.75 kW 50/60 Hz	▲		▲		▲	
	Switch-potentiometer for manual stroke frequency adjustment and to switch on the pump motor (External control of the frequency converter with mounted switch potentiometer unit is not possible)	▲		▲		▲	
	Service module hand terminal and keypad incl. 2,5m connection cable	▲		▲		▲	
<p>● = Basic design ▲ = with add. pricer -- = not available ○ = without add. price Art.-Nr. = available in basic design/accessories</p>							

Order information

Basic design

Types 411.1-...ML:

- Pump body PP
- Double valve PP-FRP
- Valve balls glass
- Valve seals FPM
- Working diaphragm PTFE
- Optical diaphragm rupture indicator with manometer

Further options and accessories:

- Connection pieces see chapter 4
- Product documentation see chapter 5

Type	Basic design	x
R411.1-60ML	16004561	
R411.1-75ML	16004560	
R411.1-105ML	16004518	
R411.1-135ML	16004521	
R411.1-400ML	16004008	
R411.1-500ML	16003826	

Motor:

- 200-254/346-440 V 50 Hz / 200-280/346-480 V 60 Hz threephase, IP 55, insul. cl. F

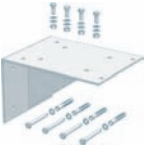
Options/Accessories		R411.1-60ML R411.1-75ML	R411.1-105ML R411.1-135ML	R411.1-400ML R411.1-500ML
Stroke frequency adjustment electrical 	Frequency converter series 8200 Vector input 4-20mA, incl. Keypad (for integration into control cabinet)			
	Single-phase 230 V, 50/60 Hz 0.75 kW	90017524	90017524	90017524
	Three-phase 320-550 V, +/- 0%, 50/60 Hz 0.75 kW	90017527	90017527	90017527
Console 	for wall mounting incl. fixing screws	90023876	90023876	90023876
	PP	90023849	90023849	90023849
● = Basic design ▲ = with add. pricer – = not available ○ = without add. price Art.-Nr. = available in basic design/accessories				

Multi-layer diaphragm pumps

Flow capacity 60 l/h ... 600 l/h

Admissible counterpressure up to 16 bar



R411.1-...ML

Fittings for suction side of dosing pumps		R411.1-60ML		R411.1-75ML		R411.1-105ML		R411.1-135ML		R411.1-400ML R411.1-500ML	
		type	p.	type	p.	type	p.	type	p.	type	p.
Suction lance	with level switch 1-stage	SL-02	3.34	SL-02	3.34	⊗		⊗		S-04	3.40
		S-03	3.38	S-03	3.38	⊗		⊗		⊗	
	with level switch 2-stage	SL-02	3.34	SL-02	3.34	⊗		⊗		⊗	
		without level switch	S-01	3.42	S-01	3.42	S-01	3.42	S-01	3.42	S-01
Suction aid / Siphon Vessel	transparent PVC-U	770.2	3.74	770.2	3.74	770.2	3.74	770.2	3.74	770.2	3.74
Calibration Pot	PVC-U	792.1	3.76	792.1	3.76	792.1	3.76	794.1	3.76	795.1	3.76
Foot valve	PVC-U	731	3.78	731	3.78	732.2	3.80	732.2	3.80	732.2	3.80
	PP / PVDF	⊗		⊗		732	3.78	732	3.78	732	3.78
	PP-FRP / PVDF-FRP	781.1	3.82	781.1	3.82	783.1	3.82	783.1	3.82	783.1	3.82
	1.4571	731	3.78	731	3.78	732	3.78	732	3.78	732	3.78
Line strainer	PVC-U / PP / PVDF	752.1	3.84	752.1	3.84	752.1	3.84	752.1	3.84	752.1	3.84
	PVC-U	751.1	3.84	751.1	3.84	⊗		⊗		⊗	
	1.4408	752	3.86	752	3.86	752	3.86	752	3.86	752	3.86
Float valve	PVC-U	871	3.88	871	3.88	872	3.88	872	3.88	872	3.88
Pulsation damper without separating diaphragm	PVC-U / PP	702.1	3.14	702.1	3.14	702.1	3.14	702.1	3.14	702.1	3.14
	1.4571	802.1	3.18	802.1	3.18	802.1	3.18	802.1	3.18	802.1	3.18
Fittings for pressure side of dosing pumps		R411.1-60ML		R411.1-75ML		R411.1-105ML		R411.1-135ML		R411.1-400ML R411.1-500ML	
		type	p.	type	p.	type	p.	type	p.	type	p.
Diaphragm-type relief valve		620.10	3.4	620.10	3.4	622.10	3.4	622.10	3.4	622.10	3.4
Diaphragm-type pressure keeping valve		620.D	3.8	620.D	3.8	622.D	3.8	622.D	3.8	622.D	3.8
Pulsation damper without separating diaphragm	PVC-U / PP	702.1	3.14	702.1	3.14	702.1	3.14	702.1	3.14	702.1	3.14
	1.4571	802.1	3.18	802.1	3.18	802.1	3.18	802.1	3.18	802.1	3.18
Diaphragm-pulsation damper with PTFE/ PTFE-faced diaphragm	PVC-U / PP / PVDF	721.2	3.24	722.1	3.24	722.1	3.24	722.1	3.24	⊗	
	1.4571	721.1	3.28	722.1	3.28	722.1	3.28	722.1	3.28	⊗	
Diaphragm-pulsation damper with Elastomer-diaphragm	PVC-U / PP / PVDF	⊗		⊗		⊗		⊗		713.1	3.20
	1.4571	810.1-0,16/180	3.30	810.1-0,32/160	3.30	810.1-0,32/160	3.30	810.1-0,32/160	3.30	810.1-2,0/100	3.30
Check valve	PVC-U	661.2	3.48	661.2	3.48	⊗		⊗		⊗	
	PP-FRP / PVDF-FRP	661.2	3.48	661.2	3.48	663.2	3.48	663.2	3.48	663.2	3.48
	1.4571	661.2	3.48	661.2	3.48	662.2	3.48	662.2	3.48	662.2	3.48
Dosing valve	PVC-U	691.1	3.54	691.1	3.54	⊗		⊗		⊗	
	PVC-U / PP / PVDF	681.1	3.58	681.1	3.58	682.1	3.58	682.1	3.58	682.1	3.58
	PP-FRP / PVDF-FRP	691.1	3.54	691.1	3.54	693.1	3.54	693.1	3.54	693.1	3.54
	1.4571	691.1	3.54	691.1	3.54	692.1	3.54	692.1	3.54	692.1	3.54
Injection fitting	PVC-U / PP / PVDF	806.1.1	3.60	806.1.1	3.60	806.2.1	3.60	806.2.1	3.60	806.2.1	3.60

⊗ = on request

The above allocation considers the fittings which have to be used at least regarding their nominal width in order to ensure the safe and trouble-free operation of the respective pumps when feeding liquids which are resembling to water.

The use of fittings of a bigger nominal width is unproblematically possible in most cases.

When choosing the fittings note the installation instructions for dosing pumps or confer with s e r a.

Air-driven diaphragm pumps

Max. flow capacity 5 l/min

Admissible counterpressure up to 7 bar



AP-5

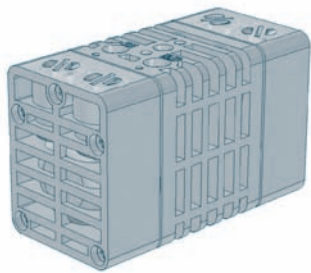

AP series in survey

- Cost-effective
- Leakage-free
- Safe against overpressure
- Low-maintenance continuous duty
- Design according to ATEX
- Safe to run dry
- Dry priming
- High-quality materials
- Robust
- Silicone-free

Infobox

Order information [Page 2.143](#)

Options/accessories [Page 2.143](#)

resistance chart [Chapter 5](#)

installation examples [Chapter 5](#)

Technical data

Type	Max. flow capacity l/min	Admissible counterpressure bar	Max. air supply bar	Control air connection	Max. suction height dry m	Max. suction height wet m	ATEX95
APB-5	5	7	7	G 1/8	3	7	II 3G Eex c IIB T4
APE-5	5	7	7	G 1/8	3	7	II 2G Eex c IIB T4

Dimensional drawing

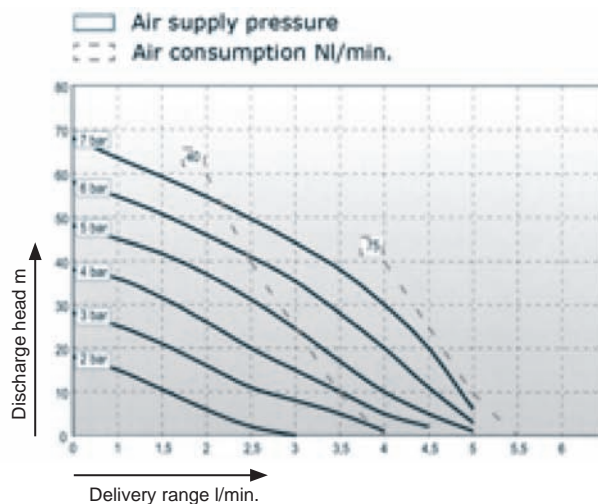
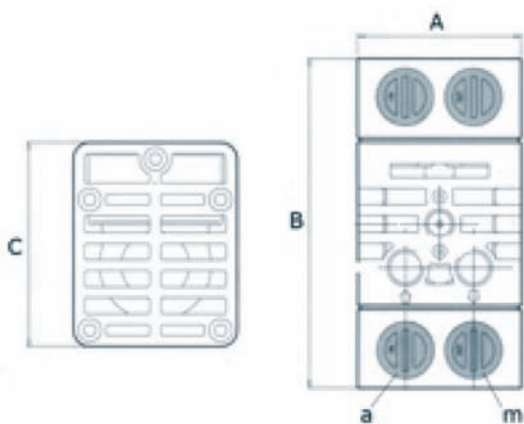

Dimensional chart



All indications in mm

Type	Connections m/a	A	B	C	Weight kg
APB-5	G 1/4	60	120	75	0.5
APE-5	G 1/4	60	120	75	0.5

Order information

Basic design

Type	Pump body	Diaphragm	Valve balls	Valve seat	article-No.	x
APB-5	PP	NBR+PTFE	Boroglas	PP/PPS-V	15000924	
APE-5	PP-CFK	NBR+PTFE	Boroglas	PP/PPS-V	15001066	

Options/Accessories					APB-5 APE-5	x		
Valve sealings	FPM				●			
	EPDM				○			
	PTFE				⊗			
Diaphragm-type pulsation damper	Type	Connection	Housing	Diaphragm				
		MPD-25.1	G 3/4	PP	Hytrel+PTFE	37602429		
				ECTFE	Santoprene	37602430		
					Santoprene-PTFE	⊗		
PPS-V				Hytrel+PTFE	37602431			
Air supply pressure unit	Filter pressure controller, shut-off valve and check valve, fittings and 5 m pneumatic hose incl.				90019599			
		as above but with solenoid valve incl. double nibble				24 V	90020022	
						230 V	90020015	
● = Basic design		○ = without add. price		⊗ = on request		Art.-Nr. = available in basic design/ accessories		

AP-15

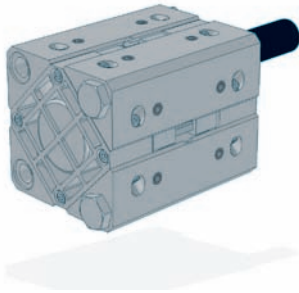

AP series in survey

- Cost-effective
- Leakage-free
- Safe against overpressure
- Low-maintenance continuous duty
- Design according to ATEX
- Safe to run dry
- Dry priming
- High-quality materials
- Robust
- Silicone-free

Infobox

- Order information [Page 2.145](#)
- Options/accessories [Page 2.145](#)
- resistance chart [Chapter 5](#)
- installation examples [Chapter 5](#)

Technical data

Type	Max. flow capacity l/min	Admissible counterpressure bar	Max. air supply bar	Control air connection	Max. suction height dry m	Max. suction height wet m	ATEX95
APB-15	15	7	7	G 3/8	3	7	II 3G Eex c IIB T4
APE-15	15	7	7	G 3/8	3	7	II 2G Eex c IIB T4

Dimensional drawing

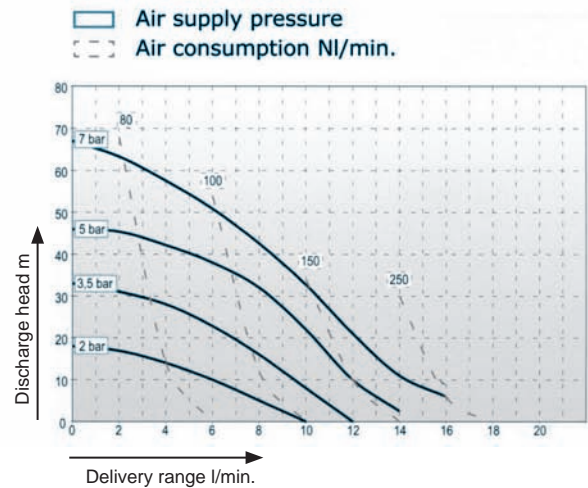
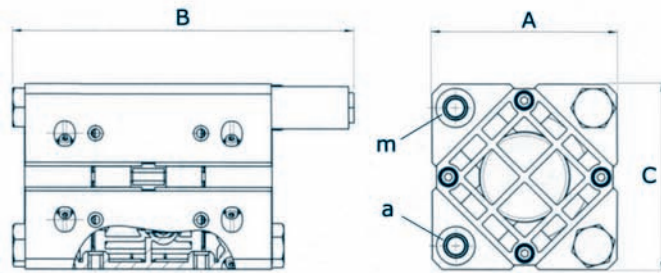

Dimensional chart



All indications in mm

Type	Connections m/a	A	B	C	Weight kg	
					PP	ECTFE
APB-15	G 3/8	105	194	105	1	1.5
APE-15	G 3/8	105	194	105	1	1.5

Order information

Basic design

Type	Pump body	Diaphragm	Valve balls	Valve seat	article-No.	x
APB-15	PP	NBR+PTFE	PTFE	PP	15001423	
APB-15	PP	NBR+PTFE	PTFE	PE	15001530	
APB-15	PP	NBR+PTFE	PTFE	AISI 316	15000926	
APB-15	PP	NBR+PTFE	AISI 316	PP	15000927	
APB-15	PP	NBR+PTFE	AISI 316	PE	15002051	
APB-15	PP	NBR+PTFE	AISI 316	AISI 316	15000928	
APB-15	ECTFE	NBR+PTFE	PTFE	ECTFE	15000931	
APB-15	ECTFE	NBR+PTFE	PTFE	AISI 316	15000932	
APB-15	ECTFE	NBR+PTFE	AISI 316	ECTFE	15000933	
APE-15	PP-CFK	NBR+PTFE	PTFE	PP	15000960	
APE-15	PP-CFK	NBR+PTFE	PTFE	AISI 316	15000964	
APE-15	PP-CFK	NBR+PTFE	AISI 316	PP	15000966	
APE-15	PP-CFK	NBR+PTFE	PTFE	PE	15000963	
APE-15	ECTFE-CFK	NBR+PTFE	PTFE	ECTFE	15000969	
APE-15	ECTFE-CFK	NBR+PTFE	PTFE	AISI 316	15000970	
APE-15	ECTFE-CFK	NBR+PTFE	AISI 316	ECTFE	15000971	

Options/Accessories					APB-15	APE-15	x	
Valve sealings	FPM				●			
	EPDM				○			
	PTFE				⊗			
Diaphragm-type pulsation damper	Type	Connection	Housing	Diaphragm				
		MPD-25.1	G 3/4	PP	Hytrel+PTFE	37602429		
				ECTFE	Santoprene	37602430		
					Santoprene+PTFE	⊗		
				PPS-V	Hytrel+PTFE	37602431		
Air supply pressure unit	Filter pressure controller, shut-off valve and check valve, fittings and 5 m pneumatic hose incl.				90019997			
		as above but with solenoid valve incl. double nibble				24 V	90020023	
						230 V	90020016	
● = Basic design ○ = without add. price ⊗ = on request Art.-Nr. = available in basic design/accessories								

AP-30

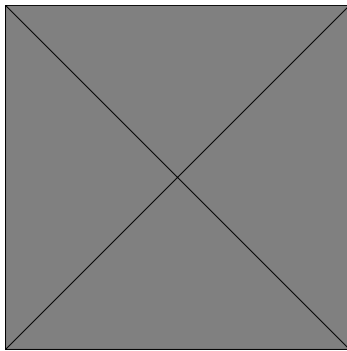

AP series in survey

- Cost-effective
- Leakage-free
- Safe against overpressure
- Low-maintenance continuous duty
- Design according to ATEX
- Safe to run dry
- Dry priming
- High-quality materials
- Robust
- Silicone-free

Infobox

Order information [Page 2.147](#)

Options/accessories [Page 2.147](#)

resistance chart [Chapter 5](#)

installation examples [Chapter 5](#)

Technical data

Type	Max. flow capacity l/min	Admissible counterpressure bar	Max. air supply bar	Control air connection	Max. suction height dry m	Max. suction height wet m	ATEX95
APB-30	30	7	7	G 1/4	7	5	II 3G Eex c IIB T4

Dimensional drawing

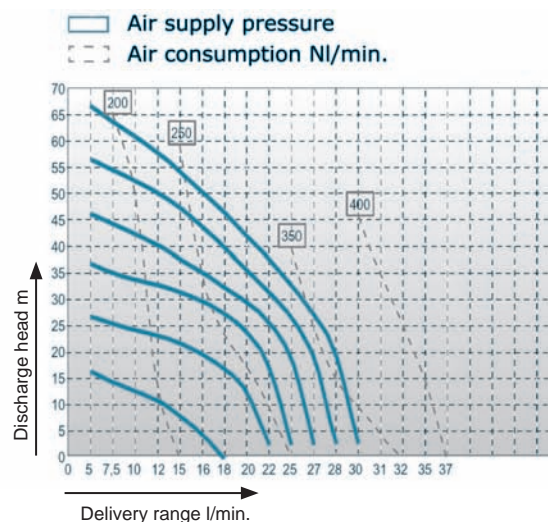
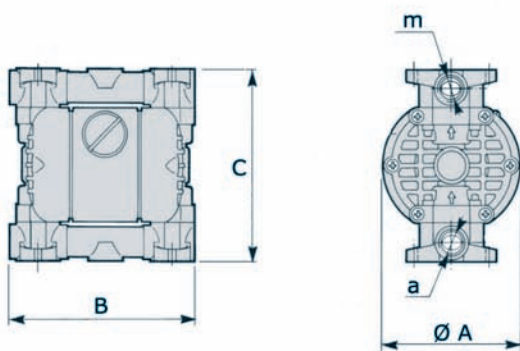

Dimensional chart



All indications in mm

Type	Connections m/a	A	B	C	Weight kg	
					PP	ECTFE
APB-30	G 1/2	120	164.5	168	1.6	1.9

Order information

Basic design

Type	Pump body	Diaphragm	Valve balls	Valve seat	article-No.	x
APB-30	PP	Santoprene	PTFE	PP	15002052	
APB-30	PP	Santoprene	AISI 316	PP	15002053	
APB-30	PP	Santoprene	PTFE	AISI 316	15002054	
APB-30	PP	Santoprene	AISI 316	AISI 316	15002055	
APB-30	PP	Santoprene/PTFE	PTFE	PP	15002374	
APB-30	PP	Santoprene/PTFE	AISI 316	PP	15002056	
APB-30	PP	Santoprene/PTFE	PTFE	AISI 316	15002057	
APB-30	PP	Santoprene/PTFE	AISI 316	AISI 316	15002058	
APB-30	ECTFE	Santoprene/PTFE	PTFE	PVDF	15001847	
APB-30	ECTFE	Santoprene/PTFE	AISI 316	PVDF	15002059	
APB-30	ECTFE	Santoprene/PTFE	PTFE	AISI 316	15002060	
APB-30	ECTFE	Santoprene/PTFE	AISI 316	AISI 316	15002061	

Options/Accessories					APB-30	x	
Valve sealings	FPM				●		
	EPDM				○		
	PTFE				⊗		
Diaphragm-type pulsation damper	Type	Connection	Housing	Diaphragm			
		MPD-25.1	G 3/4	PP	Hytrel+PTFE	37602429	
				ECTFE	Santoprene	37602430	
					Santoprene+PTFE	⊗	
PPS-V				Hytrel+PTFE	37602431		
Air supply pressure unit	Filter pressure controller, shut-off valve and check valve, fittings and 5 m pneumatic hose incl.				90019998		
		as above but with solenoid valve incl. double nibble				24 V	90020024
						230 V	90020017
● = Basic design ○ = without add. price ⊗ = on request ▲ = with add. price Art.-Nr. = available in basic design/accessories							

Air-driven diaphragm pumps

Max. flow capacity 45 l/min

Admissible counterpressure up to 7 bar



AP-45



AP series in survey

- Cost-effective
- Leakage-free
- Safe against overpressure
- Low-maintenance continuous duty
- Design according to ATEX
- Safe to run dry
- Dry priming
- High-quality materials
- Robust
- Silicone-free

Infobox

- Order information [Page 2.149](#)
- Options/accessories [Page 2.149](#)
- resistance chart [Chapter 5](#)
- installation examples [Chapter 5](#)

Technical data

Type	Max. flow capacity l/min	Admissible counterpressure bar	Max. air supply bar	Control air connection	Max. suction height dry m	Max. suction height wet m	ATEX95
APB-45	45	7	7	G 1/2	7	7	II 3G Eex c IIB T4
APE-45	45	7	7	G 1/2	7	7	II 2G Eex c IIB T4

Dimensional drawing

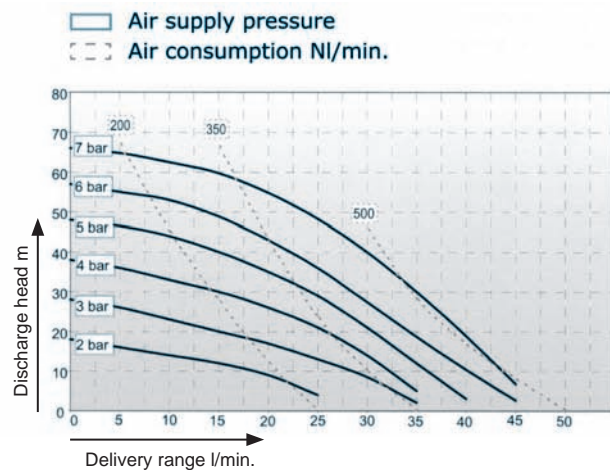
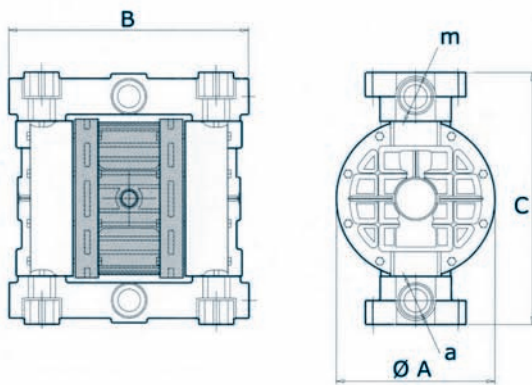

Dimensional chart

All indications in mm

Type	Connections m/a	A	B		C		Weight kg			
			plastics	metal	plastics	metal	PP	ECTFE	Aluminum	AISI316
APB-45	G 1/2	150	240	210	234	230	3.6	4.2	4.2	6.5
APE-45	G 1/2	150	240	210	234	230	3.6	4.2	4.2	6.5

Order information



Basic design

Type	Pump body	Diaphragm	Valve balls	Valve seat	article-No.	x
APB-45	PP	Santoprene	PTFE	PP	15000707	
APB-45	PP	Santoprene	PTFE	AISI 316	15000711	
APB-45	PP	Santoprene	PTFE	PE	15000712	
APB-45	PP	Santoprene	AISI 316	PP	15000716	
APB-45	PP	Santoprene	AISI 316	PE	15000717	
APB-45	PP	Hytrel+PTFE	PTFE	PP	15000720	
APB-45	PP	Hytrel+PTFE	PTFE	AISI 316	15000721	
APB-45	PP	Hytrel+PTFE	PTFE	PE	15000722	
APB-45	PP	Hytrel+PTFE	AISI 316	PP	15000723	
APB-45	PP	Hytrel+PTFE	AISI 316	PE	15000726	
APB-45	ECTFE	Santoprene/PTFE	PTFE	ECTFE	15000729	
APB-45	ECTFE	Santoprene/PTFE	AISI 316	ECTFE	15000730	
APB-45	ECTFE	Santoprene/PTFE	PTFE	AISI 316	15000733	
APB-45	Aluminium	Hytrel+PTFE	PTFE	AISI 304/PPS-V	15002062	
APB-45	Aluminium	Hytrel+PTFE	PTFE	PE/PPS-V	15002417	
APB-45	Aluminium	Hytrel+PTFE	AISI 316	AISI 304/PPS-V	15000738	
APB-45	Aluminium	Hytrel+PTFE	AISI 316	PE/PPS-V	15000739	
APB-45	AISI 316	Hytrel+PTFE	PTFE	AISI 316	15000699	
APB-45	AISI 316	Hytrel+PTFE	PTFE	PE	15000700	
APB-45	AISI 316	Hytrel+PTFE	AISI 316	AISI 316	15000701	
APB-45	AISI 316	Hytrel+PTFE	AISI 316	PE	15000702	
APE-45	PP-CFK	Santoprene	PTFE	PP	15001040	
APE-45	PP-CFK	Santoprene	PTFE	AISI 316	15001041	
APE-45	PP-CFK	Santoprene	PTFE	PE	15001045	
APE-45	PP-CFK	Santoprene	AISI 316	PP	15001046	
APE-45	PP-CFK	Santoprene	AISI 316	PE	15001047	
APE-45	PP-CFK	Hytrel+PTFE	PTFE	PP	15001050	
APE-45	PP-CFK	Hytrel+PTFE	PTFE	AISI 316	15001051	
APE-45	PP-CFK	Hytrel+PTFE	PTFE	PE	15001054	
APE-45	PP-CFK	Hytrel+PTFE	AISI 316	PP	15001055	
APE-45	PP-CFK	Hytrel+PTFE	AISI 316	PE	15001058	
APE-45	ECTFE-CFK	Santoprene/PTFE	PTFE	ECTFE	15001059	
APE-45	ECTFE-CFK	Santoprene/PTFE	AISI 316	ECTFE	15001060	
APE-45	ECTFE-CFK	Santoprene/PTFE	PTFE	AISI 316	15001061	
APE-45	Aluminium	Hytrel+PTFE	PTFE	AISI 304/PPS-V	15001062	
APE-45	Aluminium	Hytrel+PTFE	AISI 316	PE/PPS-V	15001063	
APE-45	AISI 316	Hytrel+PTFE	PTFE	AISI 316	15001036	
APE-45	AISI 316	Hytrel+PTFE	AISI 316	PE	15001039	

Options/Accessories		APB-45 APE-45	x
Valve sealings	FPM	●	
	EPDM	○	
	PTFE	⊗	
Stroke transmitting device	mounted on the pump	▲	

● = Basic design ○ = without add. price ⊗ = on request ▲ = with add. price Art.-Nr. = available in basic design/accessories

AP-45

Options/Accessories					APB-45	APE-45	x
Diaphragm-type pulsation damper 	Type	Connection	Housing	Diaphragm			
	MPD-150	G 1	PP	Santoprene	37601311		
				Hytrel+PTFE	37601310		
			ECTFE	Santoprene	37601313		
				Hytrel+PTFE	37601312		
Air supply pressure unit 	Filter pressure controller, shut-off valve and check valve, fittings and 5 m pneumatic hose incl.				90019600		
	as above but with solenoid valve incl. double nibble			24 V		90020025	
				230 V		90020018	
● = Basic design ○ = without add. price ⊗ = on request ▲ = with add. price Art.-Nr. = available in basic design/accessories							

2

Air-driven diaphragm pumps

Max. flow capacity 90 l/min

Admissible counterpressure up to 7 bar



AP-90

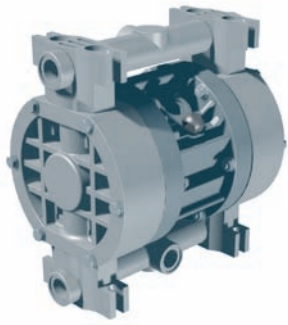

AP series in survey

- Cost-effective
- Leakage-free
- Safe against overpressure
- Low-maintenance continuous duty
- Design according to ATEX
- Safe to run dry
- Dry priming
- High-quality materials
- Robust
- Silicone-free

Infobox

- Order information [Page 2.153](#)
- Options/accessories [Page 2.153](#)
- resistance chart [Chapter 5](#)
- installation examples [Chapter 5](#)

Technical data

Type	Max. flow capacity l/min	Admissible counterpressure bar	Max. air supply bar	Control air connection	Max. suction height dry m	Max. suction height wet m	ATEX95
APB-90	90	7	7	G 1/2	7	7	II 3G Eex c IIB T4
APE-90	90	7	7	G 1/2	7	7	II 2G Eex c IIB T4

Dimensional drawing

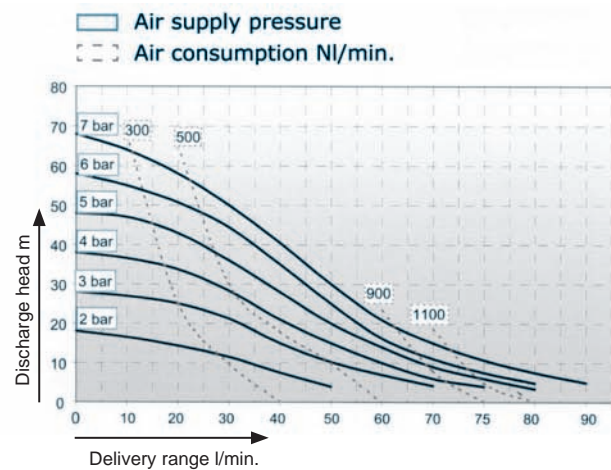
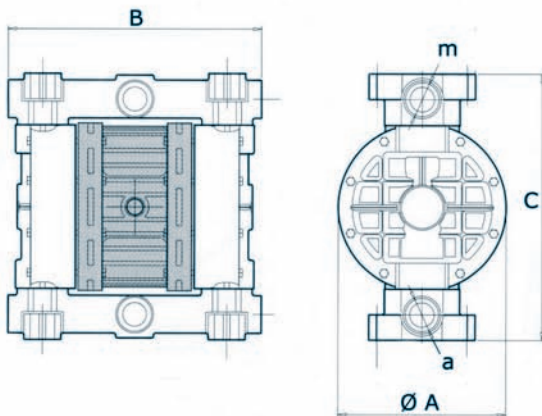

Dimensional chart

All indications in mm

Type	Connections m/a	A	B	C		Weight kg		
				plastics	metal	PP	ECTFE	AISI316
APE-90	G 1	170	305	275	270	5.5	6	12
APE-90	G 1	170	305	275	270	5.5	6	12

Order information

Basic design

Type	Pump body	Diaphragm	Valve balls	Valve seat	article-No.	x
APB-90	PP	Santoprene	PTFE	PP	15000674	
APB-90	PP	Santoprene	PTFE	AISI 316	15000675	
APB-90	PP	Santoprene	PTFE	PE	15000676	
APB-90	PP	Santoprene	AISI 316	PP	15000683	
APB-90	PP	Santoprene	AISI 316	PE	15000684	
APB-90	PP	Hytrel+PTFE	PTFE	PP	15000687	
APB-90	PP	Hytrel+PTFE	PTFE	AISI 316	15000688	
APB-90	PP	Hytrel+PTFE	PTFE	PE	15000689	
APB-90	PP	Hytrel+PTFE	AISI 316	PP	15000690	
APB-90	PP	Hytrel+PTFE	AISI 316	PE	15000691	
APB-90	ECTFE	Santoprene/PTFE	PTFE	ECTFE	15002063	
APB-90	ECTFE	Santoprene/PTFE	AISI 316	ECTFE	15002064	
APB-90	ECTFE	Santoprene/PTFE	PTFE	AISI 316	15002065	
APE-90	PP-CFK	Santoprene	PTFE	PP	15001067	
APE-90	PP-CFK	Santoprene	PTFE	AISI 316	15001068	
APE-90	PP-CFK	Santoprene	PTFE	PE	15001072	
APE-90	PP-CFK	Santoprene	AISI 316	PP	15001073	
APE-90	PP-CFK	Santoprene	AISI 316	PE	15001074	
APE-90	PP-CFK	Hytrel+PTFE	PTFE	PP	15001077	
APE-90	PP-CFK	Hytrel+PTFE	PTFE	AISI 316	15001078	
APE-90	PP-CFK	Hytrel+PTFE	PTFE	PE	15001079	
APE-90	PP-CFK	Hytrel+PTFE	AISI 316	PP	15001080	
APE-90	ECTFE-CFK	Santoprene/PTFE	PTFE	ECTFE	15001084	
APE-90	PP-CFK	Hytrel+PTFE	AISI 316	PE	15001083	
APE-90	ECTFE-CFK	Santoprene/PTFE	PTFE	PVDF	15002066	
APE-90	ECTFE-CFK	Santoprene/PTFE	PTFE	AISI 316	15001085	
APE-90	ECTFE-CFK	Santoprene/PTFE	AISI 316	ECTFE	15001088	
APE-90	ECTFE-CFK	Santoprene/PTFE	AISI 316	PVDF	15002067	
APE-90	AISI 316	Hytrel+PTFE	PTFE	AISI 316	15001089	

Options/Accessories					APB-90	APE-90	x
Valve sealings	FPM				●		
	EPDM				○		
	PTFE				⊙		
Stroke transmitting device	 mounted on the pump				▲		
Diaphragm-type pulsation damper	Type	Connection	Housing	Diaphragm			
	MPD-150	G 1	PP	Santoprene	37601311		
				Hytrel+PTFE	37601310		
	MPD-150	G 1	ECTFE	Santoprene	37601313		
Hytrel+PTFE				37601312			
● = Basic design ○ = without add. price ⊙ = on request ▲ = with add. price Art.-Nr. = available in basic design/accessories							

AP-90

Options/Accessories		APB-90	APE-90
Air supply pressure unit 	Filter pressure controller, shut-off valve and check valve, fittings and 5 m pneumatic hose incl.	90019601	✘
	as above but with solenoid valve incl. double nibble	24 V	90020019
		230 V	90020026
● = Basic design ○ = without add. price ⊗ = on request ▲ = with add. price Art.-Nr. = available in basic design/accessories			

2

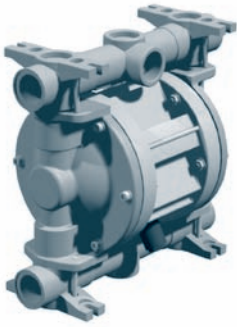

AP series in survey

- Cost-effective
- Leakage-free
- Safe against overpressure
- Low-maintenance continuous duty
- Design according to ATEX
- Safe to run dry
- Dry priming
- High-quality materials
- Robust
- Silicone-free

Infobox

Order information [Page 2.157](#)
Options/accessories [Page 2.157](#)

resistance chart [Chapter 5](#)
installation examples [Chapter 5](#)

Technical data

Type	Max. flow capacity l/min	Admissible counterpressure bar	Max. air supply bar	Control air connection	Max. suction height dry m	Max. suction height wet m	ATEX95
APB-100	100	7	7	G 1/2	7	7	II 3G Eex c IIB T4
APE-100	100	7	7	G 1/2	7	7	II 2G Eex c IIB T4

Dimensional drawing

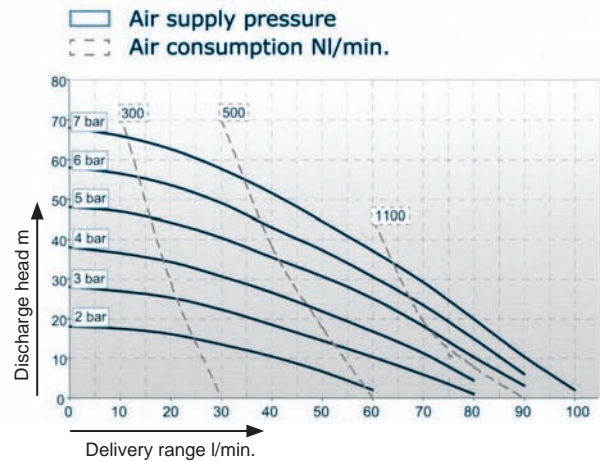
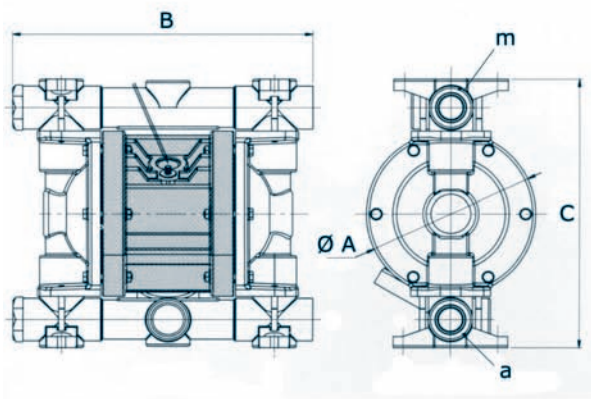

Dimensional chart



All indications in mm

Type	Connections m/a	A	B	C	Weight kg
APB-100	G 1	170	300	276	6.5
APE-100	G 1	170	300	276	6.5

Order information

Basic design

Type	Pump body	Diaphragm	Valve balls	Valve seat	article-No.	x
APB-100	Aluminium	Santoprene	PTFE	AISI 304/PPS-V	15000744	
APB-100	Aluminium	Santoprene	PTFE	PE/PPS-V	15000743	
APB-100	Aluminium	Santoprene	AISI 316	PE/PPS-V	15000748	
APB-100	Aluminium	Hytrel+PTFE	PTFE	AISI 304/PPS-V	15000750	
APB-100	Aluminium	Hytrel+PTFE	PTFE	PE/PPS-V	15000751	
APB-100	Aluminium	Hytrel+PTFE	AISI 316	AISI 304/PPS-V	15000752	
APB-100	Aluminium	Hytrel+PTFE	AISI 316	PE/PPS-V	15000753	
APE-100	Aluminium	Santoprene	PTFE	AISI 304/PPS-V	15001054	
APE-100	Aluminium	Santoprene	AISI 316	PE/PPS-V	15001057	
APE-100	Aluminium	Hytrel+PTFE	PTFE	AISI 304	15001058	
APE-100	Aluminium	Hytrel+PTFE	AISI 316	PE	15001059	

Options/Accessories					APB-100	APE-100	x	
Valve sealings	FPM				●			
	EPDM				○			
	PTFE				⊙			
Stroke transmitting device	 mounted on the pump				▲			
Diaphragm-type pulsation damper	Type	Connection	Housing	Diaphragm				
	 MPD-150	G 1	PP	Santoprene	37601311			
				Hytrel+PTFE	37601310			
			ECTFE	Santoprene	37601313			
				Hytrel+PTFE	37601312			
Air supply pressure unit	 Filter pressure controller, shut-off valve and check valve, fittings and 5 m pneumatic hose incl.				90019601			
	as above but with				24 V	90020019		
	solenoid valve incl. double nibble				230 V	90020026		
● = Basic design ○ = without add. price ⊙ = on request ▲ = with add. price Art.-Nr. = available in basic design/accessories								

AP-150

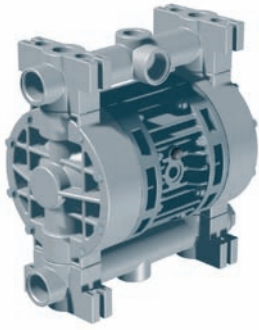

AP series in survey

- Cost-effective
- Leakage-free
- Safe against overpressure
- Low-maintenance continuous duty
- Design according to ATEX
- Safe to run dry
- Dry priming
- High-quality materials
- Robust
- Silicone-free

Infobox

Order information [Page 2.159](#)
 Options/accessories [Page 2.159](#)
 resistance chart [Chapter 5](#)
 installation examples [Chapter 5](#)

Technical data

Type	Max. flow capacity l/min	Admissible counterpressure bar	Max. air supply bar	Control air connection	Max. suction height dry m	Max. suction height wet m	ATEX95
APB-150	150	7	7	G 1/2	7	7	II 3G Eex c IIB T4
APE-150	150	7	7	G 1/2	7	7	II 2G Eex c IIB T4

Dimensional drawing

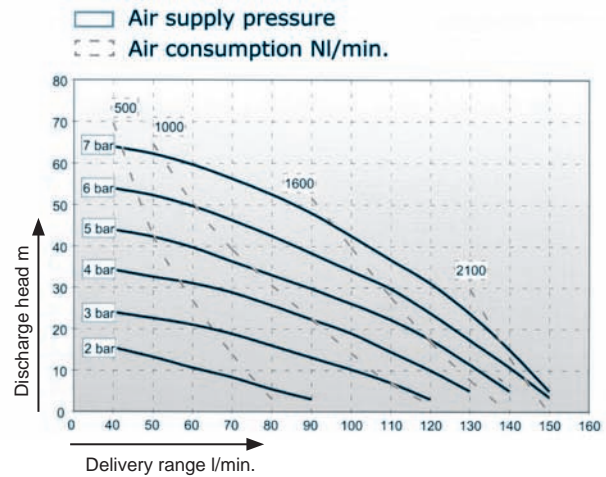
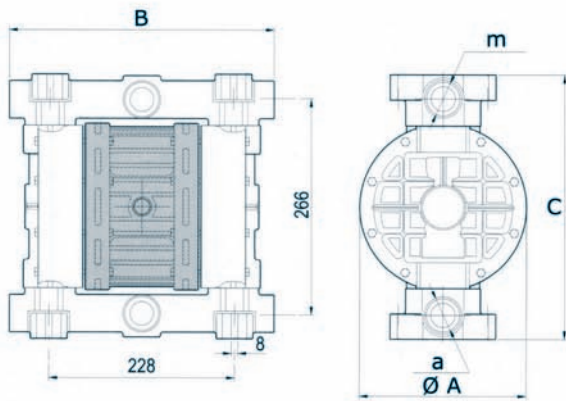

Dimensional chart



All indications in mm

Type	Connections m/a	A	B	C	Weight kg	
					PP	ECTFE
APB-150	G 1	210	325	325	7.5	8.5
APE-150	G 1	210	325	325	7.5	8.5

Order information

Basic design

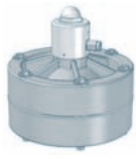
Type	Pump body	Diaphragm	Valve balls	Valve seat	article-No.	x
APB-150	PP	Santoprene	PTFE	PP	15000765	
APB-150	PP	Santoprene	PTFE	AISI 316	15000766	
APB-150	PP	Santoprene	PTFE	PP	15000767	
APB-150	PP	Santoprene	AISI 316	PP	15000774	
APB-150	PP	Santoprene	AISI 316	PE	15000775	
APB-150	PP	Hytrel+PTFE	PTFE	PP	15000778	
APB-150	PP	Hytrel+PTFE	PTFE	AISI 316	15000779	
APB-150	PP	Hytrel+PTFE	PTFE	PE	15000780	
APB-150	PP	Hytrel+PTFE	AISI 316	PP	15000781	
APB-150	PP	Hytrel+PTFE	AISI 316	PE	15000782	
APB-150	ECTFE	Santoprene/PTFE	PTFE	ECTFE	15000800	
APB-150	ECTFE	Santoprene/PTFE	PTFE	AISI 316	15000801	
APB-150	ECTFE	Santoprene/PTFE	AISI 316	ECTFE	15000802	
APE-150	PP-CFK	Santoprene	PTFE	PP	15000974	
APE-150	PP-CFK	Santoprene	PTFE	AISI 316	15000975	
APE-150	PP-CFK	Santoprene	AISI 316	PP	15002378	
APE-150	PP-CFK	Hytrel+PTFE	PTFE	PP	15002068	
APE-150	PP-CFK	Hytrel+PTFE	PTFE	AISI 316	15002069	
APE-150	PP-CFK	Hytrel+PTFE	PTFE	PE	15002070	
APE-150	PP-CFK	Hytrel+PTFE	AISI 316	PP	15000983	
APE-150	ECTFE-CFK	Santoprene/PTFE	PTFE	AISI 316	15000986	
APE-150	ECTFE-CFK	Santoprene/PTFE	AISI 316	ECTFE	15002071	

Options/Accessories					APB-150 APE-150	x	
Valve sealings	FPM				●		
	EPDM				○		
	PTFE				⊗		
Stroke transmitting device	 mounted on the pump				▲		
Diaphragm-type pulsation damper	Type	Connection	Housing	Diaphragm			
		MPD-150	G 1	PP	Santoprene	37601311	
					Hytrel+PTFE	37601310	
				ECTFE	Santoprene	37601313	
Hytrel+PTFE					37601312		
Air supply pressure unit	Filter pressure controller, shut-off valve and check valve, fittings and 5 m pneumatic hose incl.				90019601		
		as above but with solenoid valve incl. double nibble				24 V	90020019
						230 V	90020026
● = Basic design ○ = without add. price ⊗ = on request ▲ = with add. price Art.-Nr. = available in basic design/accessories							

AP-200

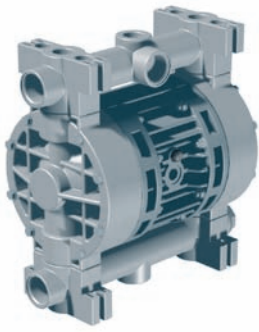

AP series in survey

- Cost-effective
- Leakage-free
- Safe against overpressure
- Low-maintenance continuous duty
- Design according to ATEX
- Safe to run dry
- Dry priming
- High-quality materials
- Robust
- Silicone-free

Infobox

Order information [Page 2.161](#)
 Options/accessories [Page 2.161](#)

resistance chart [Chapter 5](#)
 installation examples [Chapter 5](#)

Technical data

Type	Max. flow capacity l/min	Admissible counterpressure bar	Max. air supply bar	Control air connection	Max. suction height dry m	Max. suction height wet m	ATEX95
APB-200	200	7	7	G 1/2	7	7	II 3G Eex c IIB T4
APE-200	200	7	7	G 1/2	7	7	II 2G Eex c IIB T4

Dimensional drawing

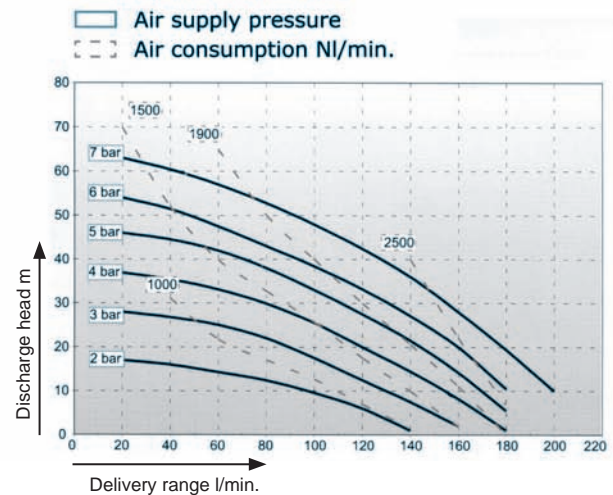
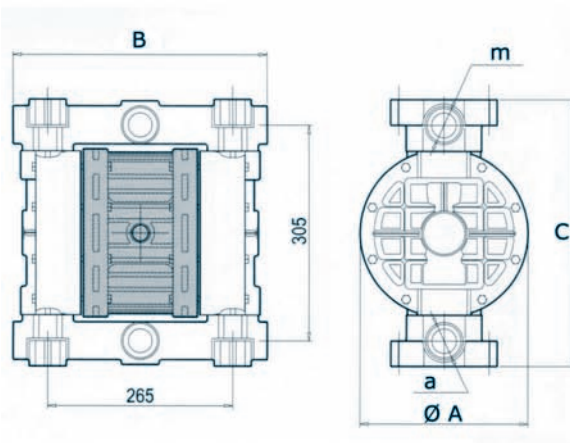

Dimensional chart

All indications in mm



Type	Connections m/a	A	B	C	Weight kg			
					PP	ECTFE	Aluminium	AISI316
APB-200	G 1 1/4	225	405	385	15	17	19	21
APE-200	G 1 1/4	225	405	385	15	17	19	21

Order information

Basic design

Type	Pump body	Diaphragm	Valve balls	Valve seat	article-No.	x
APB-200	PP	Santoprene	PTFE	PP	15000805	
APB-200	PP	Santoprene	PTFE	AISI 316	15000806	
APB-200	PP	Santoprene	PTFE	PE	15000807	
APB-200	PP	Santoprene	AISI 316	PP	15000814	
APB-200	PP	Santoprene	AISI 316	AISI 316	15000815	
APB-200	PP	Santoprene	AISI 316	PE	15000816	
APB-200	PP	Santoprene/PTFE	PTFE	PP	15000820	
APB-200	PP	Santoprene/PTFE	PTFE	AISI 316	15000821	
APB-200	PP	Santoprene/PTFE	PTFE	PE	15000822	
APB-200	PP	Santoprene/PTFE	AISI 316	PP	15000829	
APB-200	PP	Santoprene/PTFE	AISI 316	AISI 316	15000830	
APB-200	PP	Santoprene/PTFE	AISI 316	PE	15000831	
APB-200	ECTFE	Santoprene/PTFE	PTFE	ECTFE	15000835	
APB-200	ECTFE	Santoprene/PTFE	AISI 316	ECTFE	15000838	
APB-200	ECTFE	Santoprene/PTFE	PTFE	AISI 316	15000840	
APB-200	Aluminium	Hytrel+PTFE	PTFE	PP/PPS-V	15000843	
APB-200	Aluminium	Hytrel+PTFE	PTFE	AISI 304/PPS-V	15002072	
APB-200	Aluminium	Hytrel+PTFE	PTFE	PE/PPS-V	15000845	
APB-200	Aluminium	Hytrel+PTFE	AISI 316	PP/PPS-V	15000846	
APB-200	Aluminium	Hytrel+PTFE	AISI 316	AISI 304/PPS-V	15000847	
APB-200	Aluminium	Hytrel+PTFE	AISI 316	PE/PPS-V	15000848	
APB-200	AISI 316	Hytrel+PTFE	PTFE	AISI 316	15002073	
APB-200	AISI 316	Hytrel+PTFE	AISI 316	AISI 316	15002381	
APB-200	AISI 316	Hytrel+PTFE	PTFE	PE	15002382	
APB-200	AISI 316	Hytrel+PTFE	AISI 316	PE	15002383	
APE-200	PP-CFK	Santoprene	PTFE	PP	15000990	
APE-200	PP-CFK	Santoprene	PTFE	AISI 316	15000991	
APE-200	PP-CFK	Santoprene	AISI 316	PP	15000995	
APE-200	ECTFE-CFK	Santoprene/PTFE	AISI 316	ECTFE	15002076	
APE-200	ECTFE-CFK	Santoprene/PTFE	PTFE	AISI 316	15001003	
APE-200	PP-CFK	Hytrel+PTFE	PTFE	PP	15002077	
APE-200	PP-CFK	Hytrel+PTFE	PTFE	AISI 316	15002078	
APE-200	PP-CFK	Hytrel+PTFE	AISI 316	PP	15000999	
APE-200	Aluminium	Hytrel+PTFE	PTFE	AISI 304/PPS-V	15002079	
APE-200	Aluminium	Hytrel+PTFE	AISI 316	PE/PPS-V	15002080	
APE-200	AISI 316	Hytrel+PTFE	PTFE	AISI 316	15002081	
APE-200	AISI 316	Hytrel+PTFE	AISI 316	AISI 316	15002389	
APE-200	AISI 316	Hytrel+PTFE	PTFE	PP	15002390	
APE-200	AISI 316	Hytrel+PTFE	AISI 316	PE	15002084	

Options/Accessories		APB-200 APE-200	x
Valve sealings	FPM	●	
	EPDM	○	
	PTFE	⊗	
Stroke transmitting device	mounted on the pump	▲	
			
● = Basic design ○ = without add. price ⊗ = on request ▲ = with add. price Art.-Nr. = available in basic design/accessories			

Options/Accessories					APB-200	APB-200	
					APE-200	x	
Diaphragm-type pulsation damper 	Type	Connection	Housing	Diaphragm			
	MPD-340	G 1 1/2	PP	Santoprene	37601315		
				Hytrel+PTFE	37601314		
			ECTFE	Santoprene	37601317		
				Hytrel+PTFE	37601316		
Air supply pressure unit 	Filter pressure controller, shut-off valve and check valve, fittings and 5 m pneumatic hose incl.				90019601		
	as above but with solenoid valve incl. double nibble			24 V		90020019	
				230 V		90020026	
● = Basic design ○ = without add. price ⊗ = on request ▲ = with add. price Art.-Nr. = available in basic design/accessories							

2

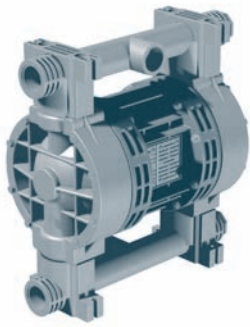

AP series in survey

- Cost-effective
- Leakage-free
- Safe against overpressure
- Low-maintenance continuous duty
- Design according to ATEX
- Safe to run dry
- Dry priming
- High-quality materials
- Robust
- Silicone-free

Infobox

- Order information [Page 2.165](#)
- Options/accessories [Page 2.165](#)
- resistance chart [Chapter 5](#)
- installation examples [Chapter 5](#)

Technical data

Type	Max. flow capacity l/min	Admissible counterpressure bar	Max. air supply bar	Control air connection	Max. suction height dry m	Max. suction height wet m	ATEX95
APB-340	340	7	7	G 1/2	7	7	II 3G Eex c IIB T4
APE-340	340	7	7	G 1/2	7	7	II 2G Eex c IIB T4

Dimensional drawing

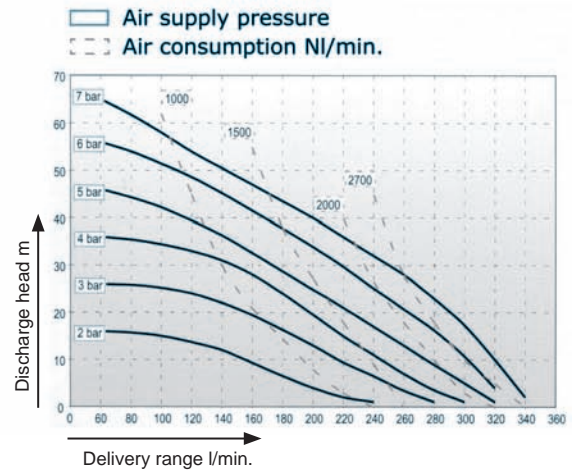
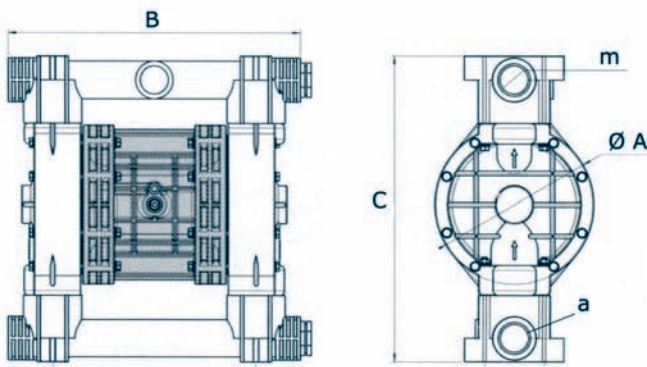

Dimensional chart

All indications in mm

Type	Connections m/a	A		B		C		Weight kg			
		plastics	metal	plastics	metal	plastics	metal	PP	ECTFE	Aluminium	AISI316
APB-340	G 1 1/2	260	254	485	480	495	491	16	20	20	32
APE-340	G 1 1/2	260	254	485	480	495	491	16	20	20	32



Order information

Basic design

Type	Pump body	Diaphragm	Valve balls	Valve seat	article-No.	x
APB-340	PP	Santoprene	PTFE	PP	15000862	
APB-340	PP	Santoprene	PTFE	AISI 316	15000863	
APB-340	PP	Santoprene	PTFE	PE	15000864	
APB-340	PP	Santoprene	AISI 316	PP	15000871	
APB-340	PP	Santoprene	AISI 316	PE	15000872	
APB-340	PP	Santoprene	EPDM	PP	15000875	
APB-340	PP	Santoprene	EPDM	PE	15000876	
APB-340	PP	Hytrel+PTFE	PTFE	PP	15002086	
APB-340	PP	Hytrel+PTFE	PTFE	AISI 316	15000879	
APB-340	PP	Hytrel+PTFE	PTFE	PE	15000880	
APB-340	PP	Hytrel+PTFE	AISI 316	PP	15000881	
APB-340	PP	Hytrel+PTFE	AISI 316	PE	15000882	
APB-340	PP	Hytrel+PTFE	EPDM	PP	15000885	
APB-340	PP	Hytrel+PTFE	EPDM	PE	15000886	
APB-340	ECTFE	Santoprene/PTFE	PTFE	PVDF	15000890	
APB-340	ECTFE	Santoprene/PTFE	AISI 316	PVDF	15000891	
APB-340	ECTFE	Santoprene/PTFE	PTFE	AISI 316	15000894	
APB-340	Aluminium	Santoprene	PTFE	AISI 304/PPS-V	15000906	
APB-340	Aluminium	Santoprene	PTFE	PE/PPS-V	15000907	
APB-340	Aluminium	Santoprene	AISI 316	PE/PPS-V	15000912	
APB-340	Aluminium	Hytrel+PTFE	PTFE	AISI 304/PPS-V	15000914	
APB-340	Aluminium	Hytrel+PTFE	PTFE	PE/PPS-V	15000915	
APB-340	Aluminium	Hytrel+PTFE	AISI 316	AISI 304/PPS-V	15000916	
APB-340	Aluminium	Hytrel+PTFE	AISI 316	PE/PPS-V	15000917	
APB-340	AISI 316	Hytrel+PTFE	PTFE	PE	1500231	
APB-340	AISI 316	Hytrel+PTFE	AISI 316	PE	15001295	
APB-340	AISI 316	Hytrel+PTFE	PTFE	AISI 316	15002392	
APB-340	AISI 316	Hytrel+PTFE	AISI 316	AISI 316	15001292	
APE-340	PP-CFK	Santoprene	PTFE	PP	15001009	
APE-340	PP-CFK	Santoprene	PTFE	AISI 316	15001010	
APE-340	PP-CFK	Santoprene	AISI 316	PE	15001015	
APE-340	PP-CFK	Hytrel+PTFE	PTFE	PP	15001016	
APE-340	PP-CFK	Hytrel+PTFE	PTFE	PE	15001017	
APE-340	PP-CFK	Hytrel+PTFE	AISI 316	PP	15001018	
APE-340	ECTFE-CFK	Santoprene/PTFE	PTFE	PVDF	15001021	
APE-340	ECTFE-CFK	Santoprene/PTFE	PTFE	AISI 316	15001024	
APE-340	ECTFE-CFK	Santoprene/PTFE	AISI 316	PVDF	15001027	
APE-340	Aluminium	Santoprene	PTFE	AISI 304/PPS-V	15001030	
APE-340	Aluminium	Santoprene	AISI 316	PE/PPS-V	15001033	
APE-340	Aluminium	Hytrel+PTFE	PTFE	AISI 304/PPS-V	15001034	
APE-340	Aluminium	Hytrel+PTFE	AISI 316	PE/PPS-V	15001035	
APE-340	AISI 316	Hytrel+PTFE	PTFE	PE	15002394	
APE-340	AISI 316	Hytrel+PTFE	AISI 316	PE	15002395	
APE-340	AISI 316	Hytrel+PTFE	PTFE	AISI 316	15002396	
APE-340	AISI 316	Hytrel+PTFE	AISI 316	AISI 316	15002397	

Options/Accessories		APB-340	APE-340	x
Valve sealings	FPM	●		
	EPDM	○		
	PTFE	⊗		
● = Basic design ○ = without add. price ⊗ = on request Art.-Nr. = available in basic design/accessories ▲ = with add. price				

AP-340

Options/Accessories					APB-340	APE-340	x
	Type MPD-340	Connection G 1 1/2	Housing PP ECTFE	Diaphragm			
				Santoprene	37601315		
				Hytrel+PTFE	37601314		
				Santoprene	37601317		
				Hytrel+PTFE	37601316		
	mounted on the pump					▲	
	Filter pressure controller, shut-off valve and check valve, fittings and 5 m pneumatic hose incl.				90019999		
				24 V	90020026		
			as above but with solenoid valve incl. double nibble	230 V	90020020		
● = Basic design ○ = without add. price ⊗ = on request Art.-Nr. = available in basic design/accessories ▲ = with add. price							

2

AP-650

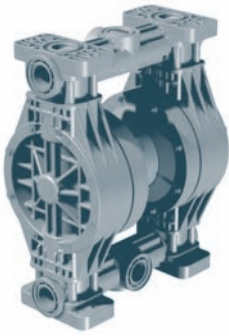

AP series in survey

- Cost-effective
- Leakage-free
- Safe against overpressure
- Low-maintenance continuous duty
- Design according to ATEX
- Safe to run dry
- Dry priming
- High-quality materials
- Robust
- Silicone-free

Infobox

Order information [Page 2.169](#)
 Options/accessories [Page 2.169](#)

 resistance chart [Chapter 5](#)
 installation examples [Chapter 5](#)

Technical data

Type	Max. flow capacity l/min	Admissible counterpressure bar	Max. air supply bar	Control air connection	Max. suction height dry m	Max. suction height wet m	ATEX95
APB-650	650	7	7	G 1/2	4	7	II 3G Eex c IIB T4

Dimensional drawing

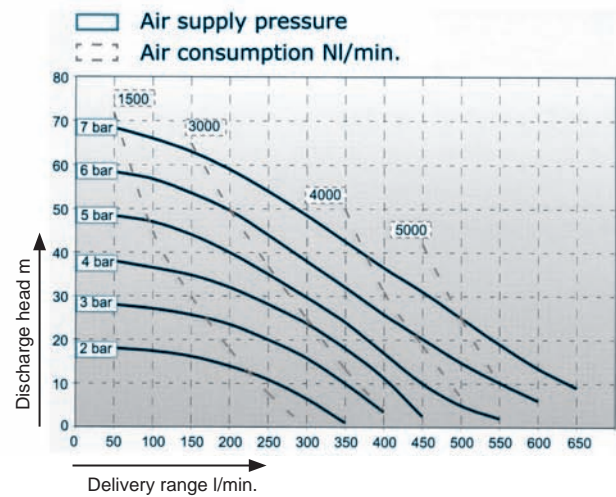
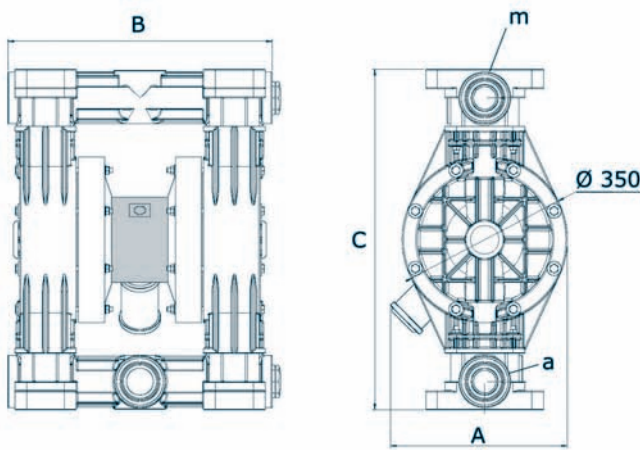

Dimensional chart

All indications in mm

Type	Connections m/a	A	B	C	Weight kg
APB-650	G 2	375	560	720	50

Order information

Basic design

Type	Pump body	Diaphragm	Valve balls	Valve seat	article-No.	x
APB-650	PP	Santoprene	PTFE	PP	15000898	
APB-650	PP	Santoprene	PTFE	PE	15000900	
APB-650	PP	Hytrel+PTFE	PTFE	PP	15002398	
APB-650	PP	Hytrel+PTFE	PTFE	PE	15002399	
APB-650	PVDF	Santoprene/PTFE	PTFE	PVDF	15002400	
APB-650	PVDF	Santoprene/PTFE	AISI 316	PVDF	15002401	

Options/Accessories					APB-650	x
Valve sealings	FPM				●	
	EPDM				○	
	PTFE				⊗	
Diaphragm-type pulsation damper	Type	Connection	Housing	Diaphragm		
		MPD-650	G 2	PP	Hytrel+PTFE	37601318
Air supply pressure unit	Filter pressure controller, shut-off valve and check valve, fittings and 5 m pneumatic hose incl.				⊗	
	as above but with solenoid valve incl. double nibble				24 V	⊗
					230 V	⊗
● = Basic design ○ = without add. price ⊗ = on request Art.-Nr. = available in basic design/accessories						

AP-850

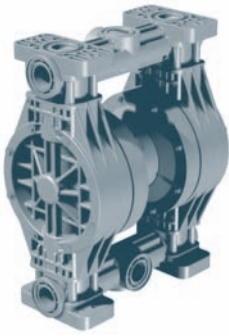

AP series in survey

- Cost-effective
- Leakage-free
- Safe against overpressure
- Low-maintenance continuous duty
- Design according to ATEX
- Safe to run dry
- Dry priming
- High-quality materials
- Robust
- Silicone-free

Infobox

Order information [Page 2.171](#)
 Options/accessories [Page 2.171](#)

resistance chart [Chapter 5](#)
 installation examples [Chapter 5](#)

Technical data

Type	Max. flow capacity l/min	Admissible counterpressure bar	Max. air supply bar	Control air connection	Max. suction height dry m	Max. suction height wet m	ATEX95
APB-850	850	7	7	G 1/2	5	7	II 3G Eex c IIB T4

Dimensional drawing

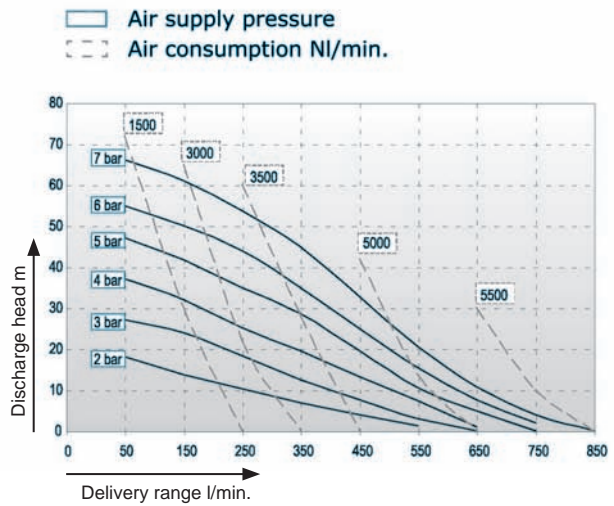
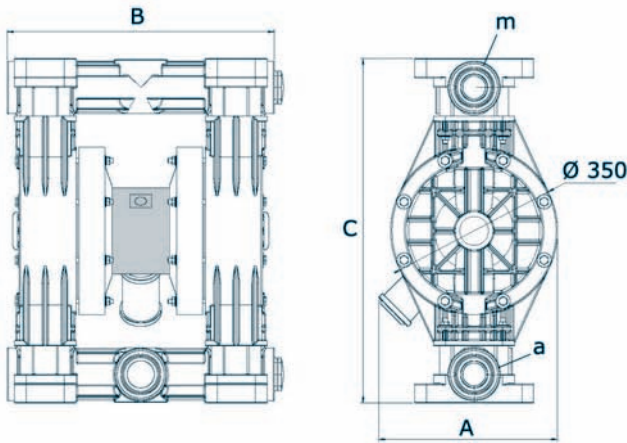

Dimensional chart



All indications in mm

Type	Connections m/a	A	B	C	Weight kg
APB-850	G 3	375	560	720	55

Order information



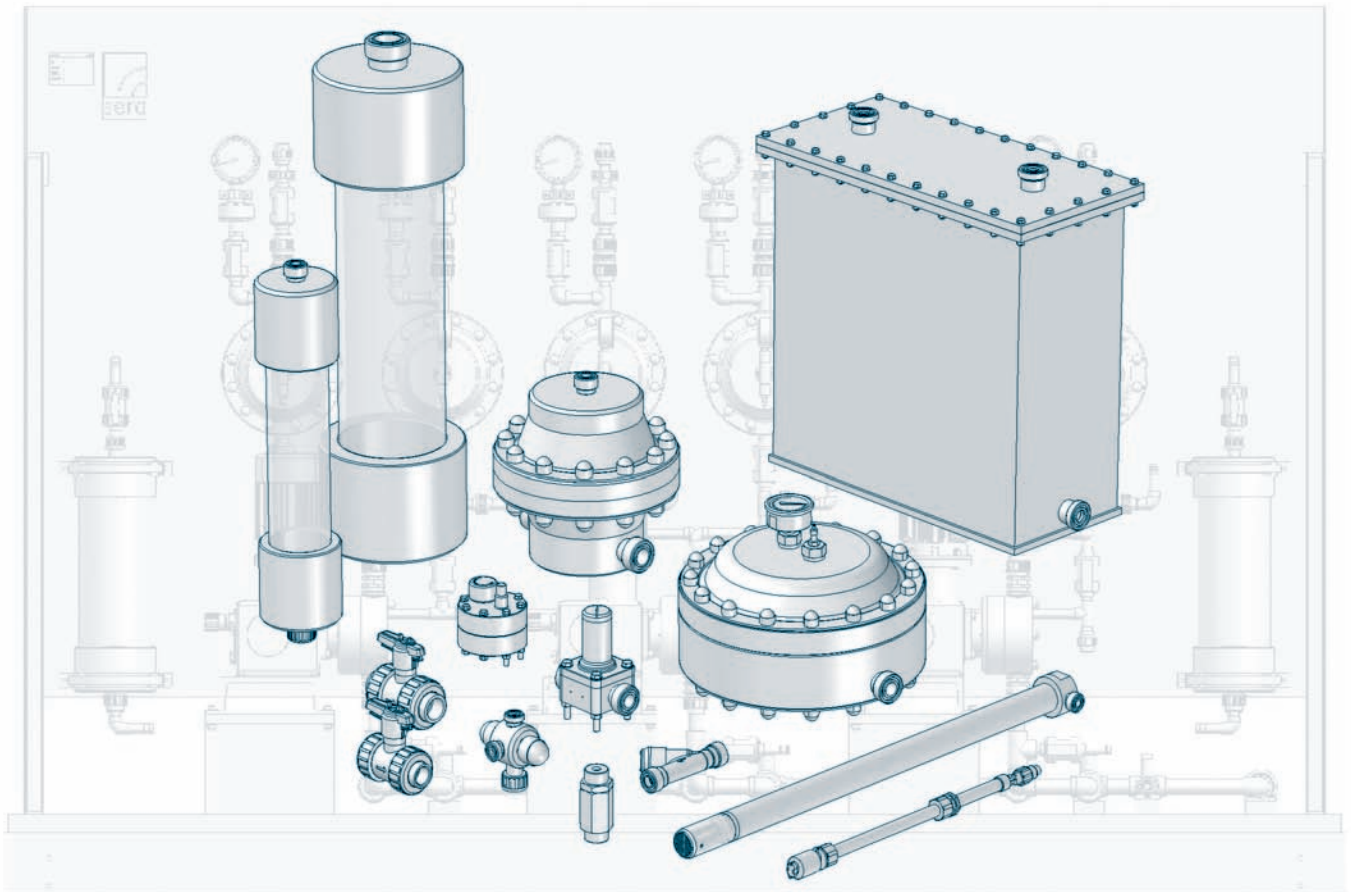

Basic design

Type	Pump body	Diaphragm	Valve balls	Valve seat	article-No.	x
APB-850	PP	Santoprene	PTFE	PP	15001303	
APB-850	PP	Santoprene	PTFE	PE	15001306	
APB-850	PP	Hytrel+PTFE	PTFE	PP	15002095	
APB-850	PP	Hytrel+PTFE	PTFE	PE	15002402	
APB-850	PVDF	Santoprene/PTFE	PTFE	PVDF	15002403	
APB-850	PVDF	Santoprene/PTFE	AISI 316	PVDF	15002098	

Options/Accessories					APB-850	x	
Valve sealings	FPM				●		
	EPDM				○		
	PTFE				⊗		
Diaphragm-type pulsation damper	Type	Connection	Housing	Diaphragm			
		MPD-850	G 3	PP	Hytrel+PTFE	37601805	
Air supply pressure unit	Filter pressure controller, shut-off valve and check valve, fittings and 5 m pneumatic hose incl.				⊗		
		as above but with solenoid valve incl. double nibble			24 V	⊗	
					230 V	⊗	
● = Basic design ○ = without add. price ⊗ = on request Art.-Nr. = available in basic design/accessories							



Fittings	Chapter content		Page
Relief- and Pressure keeping valves	Diaphragm-relief valves Diaphragm-relief valves for suspension	Diaphragm-Pressure-keeping valves Multi function valves	3.3
Pulsation damper	Pulsation damper		3.13
	Diaphragm-Pulsation damper		
Suction lances	with level switch		3.33
	without level switch		
Check valves / Injection fittings	Check valves Dosing valves Injection fittings Vent valve (manual)		3.47
Shut-off valves	Ball cocks		3.65
Fittings for the pump suction side	Foot valves Line strainer Calibration pots	Priming aids / Siphon vessels Float valves	3.71

Relief- and Pressure keeping valves	Type	Pressure range	Page	
	Diaphragm relief valves	620.10 ... 627.10	up to 10 bar	3.4
	Diaphragm relief valves for Suspension	620.S ... 627.S	up to 10 bar	3.6
	Diaphragm pressure keeping valves	620.10 ... 627.10	up to 10 bar	3.8
	Multi function valves	MFV 05004 ... MFV 05010	up to 10 bar	3.10

Relief valve / Pressure-keeping valve

Diaphragm-type relief valve
up to 10 bar

620.10 – 627.10



620.10 to 627.10 in survey

- Compact design
- Easy to mount
- Maintenance free
- Reliable
- Overpressure protection of oscillating positive displacement pumps
- High-quality materials

Infobox

- Order information [Page 3.5](#)
- Options/accessories [Page 3.5](#)
- resistance chart [Chapter 5](#)
- installation examples [Chapter 5](#)

Technical data

Type	Nominal width		Max. admissible operating pressure		Set pressure	
	DN		bar		bar	
620.10	8		10		2.5 - 10	
622.10	15		10		2.5 - 10	
623.10	20		10		1.5 - 10	
624.10	25		10		1.5 - 10	
625.10	32		10		1.5 - 10	
626.10	40		10		1.5 - 10	
627.10	50		10		1.5 - 10	

Dimensional drawing

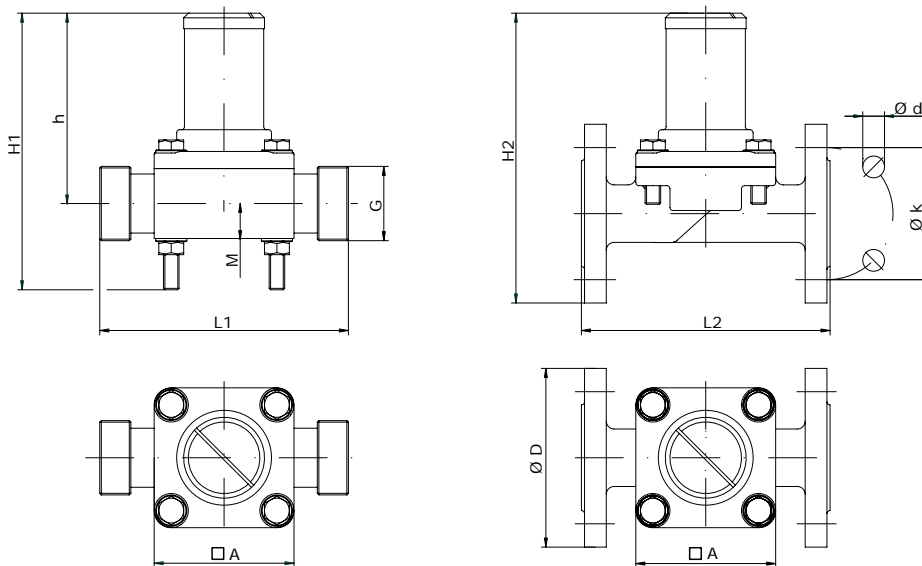

Dimensional chart

All indications in mm

Type	G	d	L1		L2	h		H1		H2	A	k	M
			plastics	1.4581		plastics	1.4571	plastics	1.4571				
620.10	G 3/4	–	80	110	–	80	80	113	108	–	50	–	13
622.10	G 1	–	115	145	–	90	88	130	129	–	72	–	16
623.10	G 1 1/4	14	130	–	150	116	–	159	–	177.5	80	75	18
624.10	G 1 1/2	14	160	–	160	123	–	166.5	–	187.5	90	85	22.5
625.10	G 2	18	180	–	180	157	–	206	–	235	100	100	24
626.10	G 2 1/4	18	235	–	200	180	–	249	–	255	115	110	30
627.10	G 2 3/4	18	260	–	230	185	–	254	–	267.5	140	125	38

Weights on request

Order information

Diaphragm-type relief valve

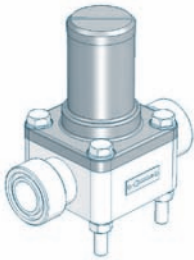

Basic design:

- Diaphragm: PTFE-faced
- Thread connection incl. connection seal: FPM

Type	Thread connection	Material							
		PVC-U	PP	PVDF	1.4581	PP-FRP	PVDF-FRP		
		article-No.	article-No.	article-No.	article-No.	article-No.	article-No.	article-No.	article-No.
620.10	G 3/4	37600007	37600014	37600029	37600605	–	–	–	–
622.10	G 1	37600008	Ⓞ	37600030	37600706	37600015	37600036	–	–
623.10	G 1 1/4	37600009	37600016	37600031	–	–	–	–	–
624.10	G 1 1/2	37600010	37600017	37600032	–	–	–	–	–
625.10	G 2	37600011	37600018	37600033	–	–	–	–	–
626.10	G 2 1/4	37600012	37600019	37600034	–	–	–	–	–
627.10	G 2 3/4	37600013	37600020	37600035	–	–	–	–	–

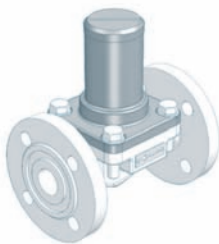

Basic design:

- Diaphragm: PTFE-faced
- Flange connection

Type	Flange Connection DN	Connection Welded joint	Material		
			1.4581	GG	GG-rubb.
			article-No.	article-No.	article-No.
623.10	20	14	36230104	37600038	37600043
624.10	25	14	36240104	37600039	37600044
625.10	32	18	36250104	37600040	37600045
626.10	40	18	36260104	37600041	37600046
627.10	50	18	37600037	37600042	37600047

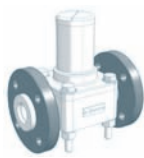
Options/Accessories		620.10	622.10 up to 627.10
Sealing for connection thread 	FPM	●	●
	EPDM	○	○
	FEP-covered	▲	▲
Loose flange at plastic fittings 	PVC-U-design: loose flange made of PVC-U	▲	▲
	PP-FRP/PVDF-FRP	–	Ⓞ
	PP-design: loose flange made of PP with steel reinforcement	▲	▲
	PVDF-design: loose flange made of PP with steel reinforcement	▲	▲

● = Basic design ○ = without add. price ▲ = with add. price Ⓞ = on request – = not available

Relief valve / Pressure-keeping valve

Diaphragm-type relief valve for suspension
up to 10 bar

622.S – 627.S



620.S to 627.S in survey

- Compact design
- Easy to mount
- Maintenance free
- Reliable
- Overpressure protection of oscillating positive displacement pumps
- High-quality materials

Infobox

Order information [Page 3.7](#)
Options/accessories [Page 3.7](#)
resistance chart [Chapter 5](#)
installation examples [Chapter 5](#)

Technical data

Type	Nominal width	Max. admissible operating pressure	Set pressure	Max. solids content at max. grain size of 10 µm
	DN	bar	bar	
622.S	15	10	1.5 - 4.5	10 %
623.S	20	10	1.5 - 5.5	10 %
624.S	25	10	1.5 - 5	10 %
625.S	32	10	1.5 - 10	10 %
626.S	40	10	1.5 - 8.5	10 %
627.S	50	10	1.5 - 10	10 %

Dimensional drawing

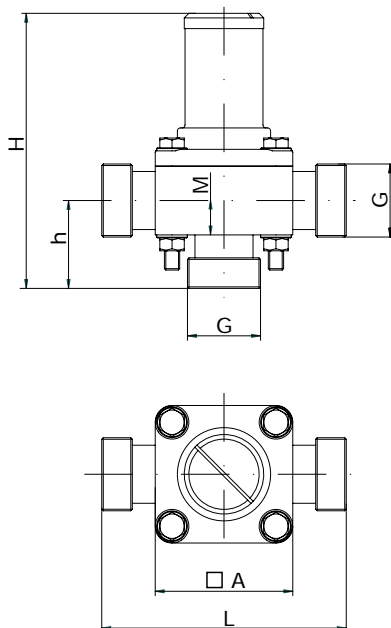

Dimensional chart

All indications in mm

Type	G	L	h	H	A	M
622.S	G 1	115	45	132	72	17
623.S	G 1 1/4	130	47	163	80	18
624.S	G 1 1/2	160	58	180	90	23.5
625.S	G 2	210	105	266	100	38
626.S	G 2 1/4	230	115	295	115	40
627.S	G 2 3/4	250	125	310	140	48

Weights on request

Order information

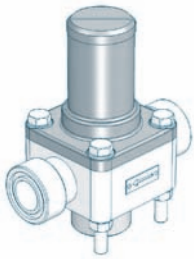

Diaphragm-type relief valve for suspension



Basic design

- Diaphragm CSM (Hypalon)
- Thread connection incl. connection seal FPM

Type	Thread connection	Material			
		PVC-U article-No.	PP article-No.	PVDF article-No.	1.4571 article-No.
622.S	G 1	37600098	37600112	37600126	⊙
623.S	G 1 1/4	37600099	37600113	37600127	⊙
624.S	G 1 1/2	37600100	37600114	37600128	⊙
625.S	G 2	37600101	37600115	37600129	⊙
626.S	G 2 1/4	37600102	37600116	37600130	⊙
627.S	G 2 3/4	37600103	37600117	37600131	⊙

Options/Accessories		622.S up to 627.S	x
Sealing for connection thread 	FPM	●	
	EPDM	○	
	FEP-covered	▲	
Loose flange at plastic fittings 	PVC-U-design: loose flange made of PVC-U	▲	
	PP-design: loose flange made of PP with steel reinforcement	–	
	PVDF-design: loose flange made of PP with steel reinforcement	▲	
● = Basic design ○ = without add. price ▲ = with add. price			

Relief valve / Pressure-keeping valve

Diaphragm-type pressure-keeping valve
up to 10 bar



620.D – 627.D



620.D - 627.D in survey

- Compact design
- Easy to mount
- Maintenance free
- Reliable
- High-quality materials

Infobox

Order information [Page 3.9](#)
Options/accessories [Page 3.9](#)
resistance chart [Chapter 5](#)
installation examples [Chapter 5](#)

Technical data

Type	Nominal width	Max. admissible operating pressure	Set pressure
	DN		
620.D	8	10	1.5 - 2
622.D	15	10	1 - 2
623.D	20	10	1 - 3.5
624.D	25	10	1 - 3
625.D	32	10	1 - 7
626.D	40	10	1 - 7
627.D	50	10	1 - 7

Dimensional drawing

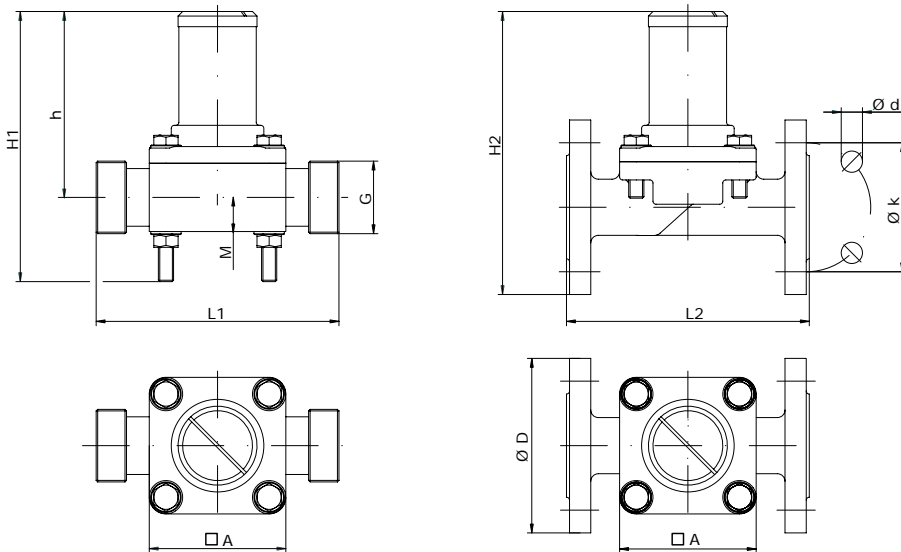

Dimensional chart

All indications in mm

Type	G	d	L1		L2	h		H1		H2	A	k	M
			plastics	1.4581		plastics	1.4571	plastics	1.4571				
620.D	G 3/4	–	80	110	–	80	80	113	108	–	50	–	13
622.D	G 1	–	115	145	–	90	88	130	129	–	72	–	16
623.D	G 1 1/4	14	130	–	150	116	–	159	–	177.5	80	75	18
624.D	G 1 1/2	14	160	–	160	123	–	166.5	–	187.5	90	85	22.5
625.D	G 2	18	180	–	180	157	–	206	–	235	100	100	24
626.D	G 2 1/4	18	235	–	200	180	–	249	–	255	115	110	30
627.D	G 2 3/4	18	260	–	230	185	–	254	–	267.5	140	125	38

Weights on request

Order information

Diaphragm-type pressure-keeping valve

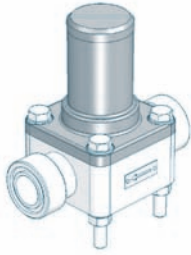

Basic design:

- Diaphragm: PTFE-faced
- Thread connection incl. connection seal: FPM

Type	Thread connection	Material							
		PVC-U	PP	PVDF	1.4581	PP-FRP	PVDF-FRP		
		article-No.	article-No.	article-No.	article-No.	article-No.	article-No.	article-No.	
620.D	G 3/4	37600048	37600055	37600070	37600601	–	–	–	
622.D	G 1	37600049	⊙	37600071	37600533	37600056	37600077		
623.D	G 1 1/4	37600050	37600057	37600072	–	–	–		
624.D	G 1 1/2	37600051	37600058	37600073	–	–	–		
625.D	G 2	37600052	37600059	37600074	–	–	–		
626.D	G 2 1/4	37600053	37600060	37600075	–	–	–		
627.D	G 2 3/4	37600054	37600061	37600076	–	–	–		

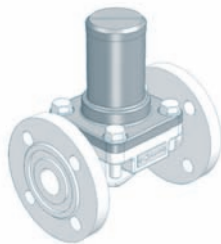

Basic design:

- Diaphragm: PTFE-faced
- Flange connection

Type	Flange Connection DN	Material		
		1.4581	GG	GG-rubb.
		article-No.	article-No.	article-No.
623.D	20	36231104	37600080	37600085
624.D	25	36241104	37600081	37600086
625.D	32	36251104	37600082	37600087
626.D	40	37600078	37600083	37600088
627.D	50	37600079	37600084	37600089

Options/Accessories

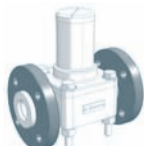
Options/Accessories		620.D		622.D up to 627.D	
			✘		✘
Sealing for connection thread 	FPM	●		●	
	EPDM	○		○	
	FEP-covered	▲		▲	
Loose flange at plastic fittings 	PVC-U-design: loose flange made of PVC-U	▲		▲	
	PP-FRP/PVDF-FRP	–		⊙	
	PP-design: loose flange made of PP with steel reinforcement	▲		▲	
	PVDF-design: loose flange made of PP with steel reinforcement	▲		▲	

● = Basic design ○ = without add. price ▲ = with add. price ⊙ = on request – = not available



MFV 05004 to MFV 05010 in survey

- Compact design
- Easy to mount
- Maintenance free
- Overpressure protection for dosing pumps
- Venting
- High-quality materials

Infobox

- Order information [Page 3.11](#)
- Options/accessories [Page 3.11](#)
- resistance chart [Chapter 5](#)
- installation examples [Chapter 5](#)

Technical data

Type	Opening pressure bar	Holding pressure bar
MFV 05004	4	1 - 1.5
MFV 05006	6	1 - 1.5
MFV 05010	10	1 - 1.5

Dimensional drawing

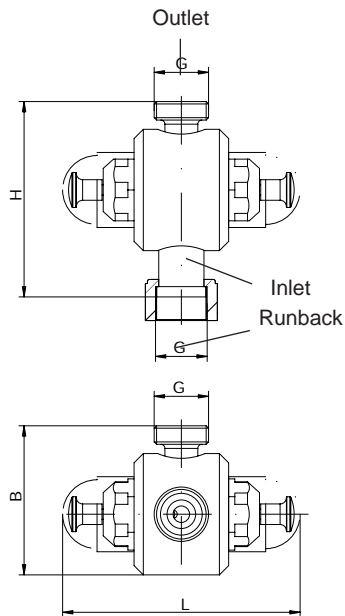

Dimensional chart

All indications in mm

Type	G	L	H	B	Weight		
					PVC-U	PP	PVDF
MFV 05004	G 3/4	130	95	72	0.25	0.2	0.25
MFV 05006	G 3/4	130	95	72	0.25	0.2	0.25
MFV 05010	G 3/4	130	95	72	0.25	0.2	0.25

Order information
Multi-function valve





Basic design:

- Diaphragm: PTFE-faced
- Thread connection incl. connection seal: FPM

Type	Thread connection	Material		
		PVC-U	PP	PVDF
		article-No.	article-No.	article-No.
MFV 05004	G 3/4	37600968	37600977	37601064
MFV 05006	G 3/4	37600971	37600980	37601067
MFV 05010	G 3/4	37600974	37600983	37601070

Options/Accessories		MFV 05004 up to MFV 05010	
Sealing for connection thread 	FPM	●	x
	EPDM	○	
	FEP-covered	▲	
● = Basic design ○ = without add. price ▲ = with add. price			

Pulsation damper Type	Pressure range	for pumps with capacity up to	Page
 702.1 ... 706.1	up to 10 bar	4000 l/h	3.14
 802.1 ... 806.1	up to 16 bar	4000 l/h	3.18

Diaphragm Pulsation damper Type	Pressure range	for pumps with capacity up to	Page
 713.1 ... 715.1	up to 10 bar	4000 l/h	3.20
 713.1 ... 715.1	up to 16 bar	4000 l/h	3.22
 720.1 ... 723.1	up to 10 bar	600 l/h	3.24
 721.1 ... 724.1	up to 50 bar	900 l/h	3.28
 810.1	up to 180 bar	900 l/h	3.30



702.1 to 706.1 in survey

- Easy to operate
- Low maintenance
- Long service life
- Easy to install
- High-quality materials
- Design acc. to 97/23/EG

Infobox

- Order information [Page 3.15](#)
- Options/accessories [Page 3.15](#)
- resistance chart [Chapter 5](#)
- installation examples [Chapter 5](#)

Technical data

Type	Nominal width DN	Max. admissible operating pressure bar	Content l
702.1	15	10	2
703.1	20	10	5
706.1	40	10	10

Dimensional drawing

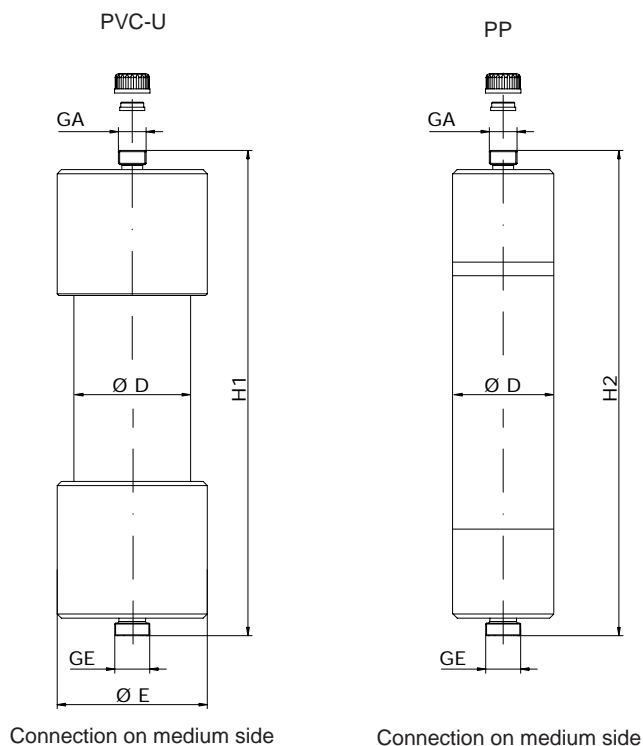

Dimensional chart

All indications in mm

Type	GE	GA	D	H1	H2	E	Weight kg	
							PVC-U	PP
702.1	G 1	G 1	90	556	534	120	3.2	1.4
703.1	G 1 1/4	G 1	140	582	556	180	9	3.2
706.1	G 2 1/4	G 1	160	786	847	220	13.4	6.2

Order information

Pulsation damper



Basic design:

- Connection for medium side: external thread
- Connection for filling device: closed blind

Type	Thread connection GE	Material	
		PVC-U/EPDM	PVC-U/FPM
		article-No.	article-No.
702.1	G 1	30095004	30095001
703.1	G 1 1/4	30095005	30095002
706.1	G 2 1/4	30095006	30095003



Basic design:

- Connection for medium side: external thread
- Connection for filling device: closed blind

Type	Thread connection GE	Material	
		PP/EPDM	PP/FPM
		article-No.	article-No.
702.1	G 1	30095004	30095001
703.1	G 1 1/4	30095005	30095002
706.1	G 2 1/4	30095006	30095003

Options/Accessories

702.1 DN15 x 703.1 DN20 x 706.1 DN40 x

Loose flange at plastic fittings

Design:
Connection incl. connection o-ring
Connecting dimension acc. to DIN 2501



PVC-U-design: loose flange made of PVC-U	▲	▲	▲
PP-design: loose flange made of PP with steel reinforcement	▲	▲	▲

Filling device

Design:
Check valve PVDF-FRP, spring-loaded, valve ball PTFE, spring Hastelloy C4, two-way ball cock
Filling connection: hose nozzle d 10
Connection: union nut G1



PVC-U/EPDM	37600303	37600303	37600303
PVC-U/FPM	37600304	37600304	37600304
PP/EPDM	37600305	37600305	37600305
PP/FPM	37600306	37600306	37600306
Filling joint for compressed air coupling or foot pump	Ⓞ	Ⓞ	Ⓞ

Filling and pressure measuring devices

Design:
Check valve PVDF-FRP, spring-loaded, valve ball PTFE, spring Hastelloy C4, two-way ball cock
Filling connection: hose nozzle d 10
Manometer glycerine-damped made of 1.4301, measuring-system copper alloy d 63, 0-16 bar, other manometers on request, diaphragm pressure transmitter G 1/4, diaphragm: PTFE-faced
Connection: union nut G1





PVC-U/EPDM	37600307	37600307	37600307
PVC-U/FPM	37600308	37600308	37600308
PP/EPDM	37600309	37600309	37600309
PP/FPM	37600310	37600310	37600310
Filling joint for compressed air coupling or foot pump	Ⓞ	Ⓞ	Ⓞ

Art.-Nr. = available in Basic design/accessories

Ⓞ = on request

▲ = with add. price

Options/Accessories			702.1 DN15	703.1 DN20	706.1 DN40
	PE	d 90	90010657	–	–
		d 140	–	90010660	–
		d 160	–	–	90010661
	PP		90010913	90010913	90010913
		1.4301	90010911	90010911	90010911
Wall mounted console + retaining clamp are necessary for the mounting of the pulsation damper.					
Art.-Nr. = available in Basic design/accessories ☉ = on request ▲ = with add. price					



802.1 to 806.1 in survey

- Easy to operate
- Low-maintenance
- Long service life
- Easy to install
- Design acc. to 97/23/EG
- High-quality materials

Infobox

- Order information [Page 3.19](#)
- Options/accessories [Page 3.19](#)
- resistance chart [Chapter 5](#)
- installation examples [Chapter 5](#)

Technical data

Type	Nominal width DN	Max. admissible operating pressure bar	Content l
802.1	15	25	2
803.1	20	16	10
804.1	25	16	10
805.1	32	16	10
806.1	40	16	10

Dimensional drawing

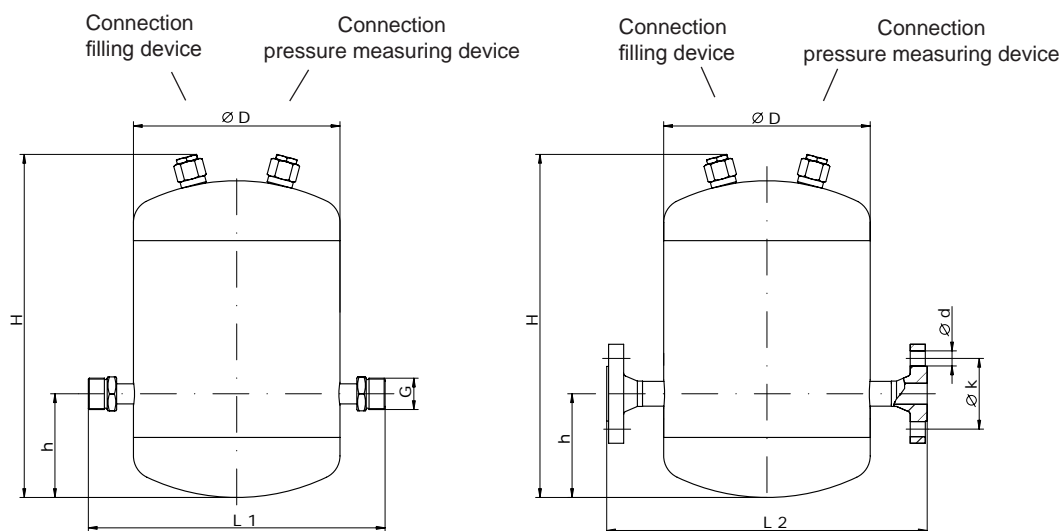

Flange connections acc. to DIN2633

Dimensional chart

All indications in mm

Type	G	d	D	L1	L2	h	H	K	Weight kg
802.1	G 1	–	114.3	210	–	66	318	–	3.4
803.1	–	105	219.1	–	340	110	365	75	11.2
804.1	–	115	219.1	–	400	110	365	85	11.5
805.1	–	140	219.1	–	400	110	365	100	12.5
806.1	–	150	219.1	–	400	110	365	110	13

Order information

Pulsation damper

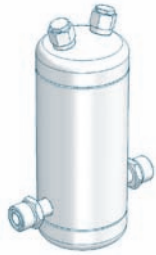

Basic design:

- Connection seal: O-ring FEP-covered,
- 2 connections for filling / pressure measuring

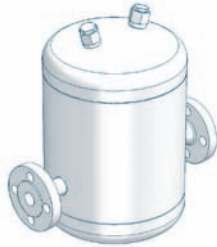

Type	Thread connection G	Material 1.4571	
		article-No.	
802.1	G 1	31101001	



Basic design:

- 2 connections for filling / pressure measuring

Type	Flange Connection DN	Material 1.4571	
		article-No.	
803.1	20	31102003	
804.1	25	31103001	
805.1	32	31104001	
806.1	40	31105001	

Options/Accessories		802.1	803.1 up to 806.1
		✕	✕
Filling device 	Design: Seal made of PTFE-FEP Check valve 1.4571, spring-loaded Valve ball 1.4401, spring Hastelloy C4 Shut-off valve 1.4571 Filling connection: hose nozzle d 10 Connection: G 1/2 external		
	1.4571	37600311	37600311
	Plug-in nipple for compressed air coupling	Ⓞ	Ⓞ
	Filling joint for Filling pump FLP2	Ⓞ	Ⓞ
Pressure measuring device 	Design: Seal: PTFE Incl. shut-off fitting and manometer, glycerine damped, d 100 Connection G 1/2 external		
	1.4571	-1 - 3 bar 37601810	37601810
		0 - 40 bar 37600312	-
		0 - 25 bar -	37601211
Fixing clamp 	galvanized steel / EPDM		
	d 120	30085004	-
	d 220	-	30085005
Art.-Nr. = available in Basic design/accessories		Ⓞ = on request	

713.1 – 715.1



713.1/715.1 in survey

- Easy to operate
- Low-maintenance
- Long service life
- Easy to install
- Design acc. to 97/23/EG
- High-quality materials

Infobox

- Order information [Page 3.21](#)
- Options/accessories [Page 3.21](#)
- resistance chart [Chapter 5](#)
- installation examples [Chapter 5](#)

Technical data

Type	Nominal width		Max. admissible operating pressure		Content	
	DN		bar		l	
713.1	15		10		3	
713.1	20		10		3	
713.1	25		10		3	
715.1	25		10		5	
715.1	32		10		5	
715.1	40		10		5	

Dimensional drawing

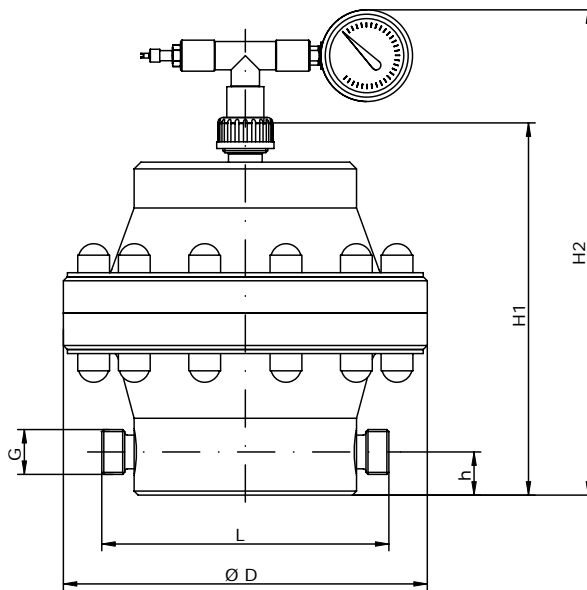

Dimensional chart

All indications in mm

Type	G	D	L			h	H1	H2	Weight kg	
			PVC-U	PP	PVDF				PVC-U	PP/PVDF
713.1	G 1	270	213	263	255	32	271	360	6.5	9
713.1	G 1 1/4	270	207	215	215	32	271	360	6.5	9
713.1	G 1 1/2	270	235	243	243	32	271	360	6.5	9
715.1	G 1 1/2	300	270	339	339	42	320	410	9	14.5
715.1	G 2	300	265	280	280	42	320	410	9	14.5
715.1	G 2 1/4	300	280	280	280	42	320	410	9	14.5

Order information

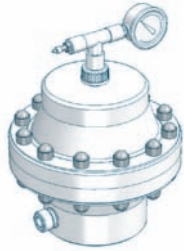

Diaphragm-pulsation damper



Basic design:

- Filling valve, diaphragm made of EPDM or FPM, Connection seals o-ring EPDM or FPM
- Manometer glycerine damped, d 63, 0-16 bar, housing, 1.4301, measuring system copper-alloy based,
- PVDF-design: upper part (not medium-contacting) made of PVC-U
- Connections: external thread

Type	Thread connection	Material					
		PVC-U/EPDM	PVC-U/FPM	PP/EPDM	PP/FPM	PVDF/EPDM	PVDF/FPM
		article-No.	article-No.	article-No.	article-No.	article-No.	article-No.
713.1	G 1	30071034	30071035	30071036	30071037	30071058	30071059
713.1	G 1 1/4	30071038	30071039	30071040	30071041	30071060	30071061
713.1	G 1 1/2	30071042	30071043	30071044	30071045	30071062	30071063
715.1	G 1 1/2	30071046	30071047	30071048	30071049	30071064	30071065
715.1	G 2	30071050	30071051	30071052	30071053	30071066	30071067
715.1	G 2 1/4	30071054	30071055	30071056	30071057	30071068	30071069

Options/Accessories		713.1	715.1	
Loose flange at plastic fittings 	Design: Connection incl. connection o-ring Connecting dimension acc. to DIN 2501			
		DN 15	▲	–
		DN 20	▲	–
	PVC-U-design: loose flange made of PVC-U	DN 25	▲	▲
		DN 32	–	▲
		DN 40	–	▲
		DN 15	▲	–
	PP-design: loose flange made of PP with steel reinforcement	DN 20	▲	–
		DN 25	▲	▲
		DN 32	–	▲
		DN 40	–	▲
	PVDF-design: loose flange made of PP with steel reinforcement	DN 15	▲	–
		DN 20	▲	–
		DN 25	▲	▲
		DN 32	–	▲
		DN 40	–	▲
Filling pump FLP 2 	for filling device, max. 7 bar, with manometer, 2 m hose, coupling piece for air filling valve	90009396	90009396	
Console 		PP	90010913	90010913
	for wall mounting made of:	1.4301	90010914	90010914
		painted steel	90010915	90010915
▲ = with add. price		– = not available		Art.-Nr. = available in Basic design/accessories



713.1/715.1 in survey

- Easy to operate
- Low-maintenance
- Long service life
- Easy to install
- Design acc. to 97/23/EG
- High-quality materials

Infobox

- Order information [Page 3.23](#)
- Options/accessories [Page 3.23](#)
- resistance chart [Chapter 5](#)
- installation examples [Chapter 5](#)

Technical data

Type	Nominal width	Max. admissible operating pressure	Content
	DN	bar	l
713.1	15	16	3
713.1	20	16	3
713.1	25	16	3
715.1	25	16	5
715.1	32	16	5
715.1	40	16	5

Dimensional drawing

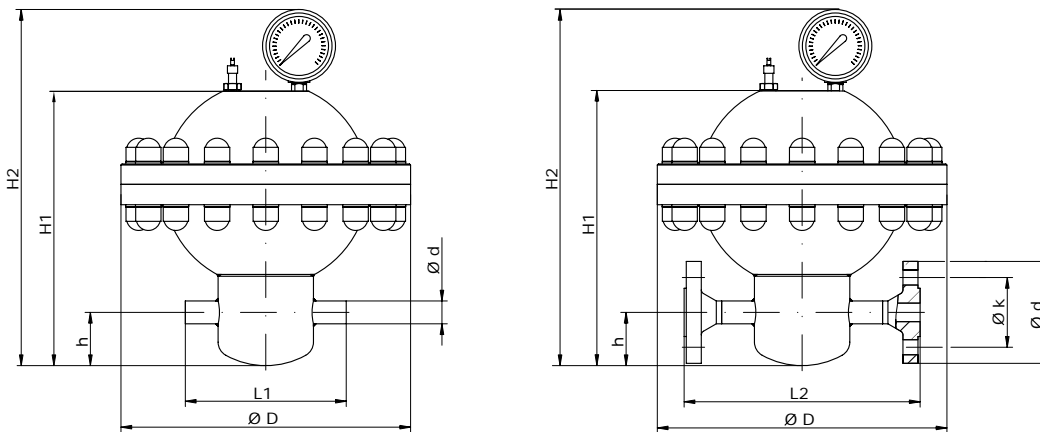

Flange connections acc. to DIN2633

Dimensional chart

All indications in mm

Type	DN	d		D	L1	L2	h	H1	H2	K
		welded joint	flange							
713.1	15	21.3	95	270	150	220	50	256	332	65
713.1	20	26.9	105	270	144	220	50	256	332	75
713.1	25	33.7	115	270	144	220	50	256	332	85
715.1	25	33.7	115	300	184	260	60	297	373	85
715.1	32	42.4	140	300	180	260	60	297	373	100
715.1	40	48.3	150	300	176	260	60	297	373	110

Weights on request

Order information

Diaphragm-pulsation damper

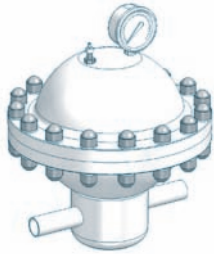

Basic design:

- Filling valve, diaphragm made of EPDM or FPM, upper part (not medium-contacting) 1.4305,
- Manometer glycerine-damped, d63, 0-25 bar, housing 1.4301, measuring system copper-alloy,
- Connection: welded joint

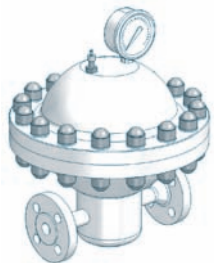

Type	Connection welded joint d	Material	
		1.4571/EPDM article-No.	1.4571/FPM article-No.
713.1	21.3	30071070	30071071
713.1	26.9	30071072	30071073
713.1	33.7	30071074	30071075
715.1	33.7	30071076	30071077
715.1	42.4	30071078	30071079
715.1	48.3	30071080	30071081



Basic design:

- Filling valve, diaphragm made of EPDM or FPM, upper part (not medium-contacting) 1.4305,
- Manometer glycerine-damped, d63, 0-25 bar, housing 1.4301, measuring system copper-alloy,
- Connection: flange acc. to DIN 2633

Type	Flange Connection DN	Material	
		1.4571/EPDM article-No.	1.4571/FPM article-No.
713.1	15	30071082	30071083
713.1	20	30071084	30071085
713.1	25	30071086	30071087
715.1	25	30071088	30071089
715.1	32	30071090	30071091
715.1	40	30071092	30071093

Options/Accessories		713.1 715.1	
Filling pump FLP 2 	for filling device, max. 7 bar, with manometer, 2 m hose, coupling piece for air filling valve		90009396
Console 	for wall mounting made of:	1.4301	90010914
		painted steel	

Art.-Nr. = available in Basic design/accessories

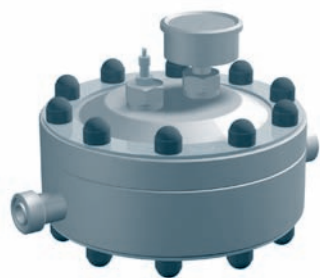

720.1 to 723.1 in survey

- Easy to operate
- Low-maintenance
- Long service life
- Any fitting position
- Easy to install
- Design acc. to 97/23/EG
- High-quality materials

Infobox

- Order information [Page 3.25](#)
- Options/accessories [Page 3.25](#)
- resistance chart [Chapter 5](#)
- installation examples [Chapter 5](#)

Technical data

Type	Nominal width DN	Max. admissible operating pressure bar	Content l
720.1	5	10	0.025
721.2	10	10	0.14
722.1	15	10	0.32
723.1	20	10	0.86

Dimensional drawing

720.1

712.2 - 723.1

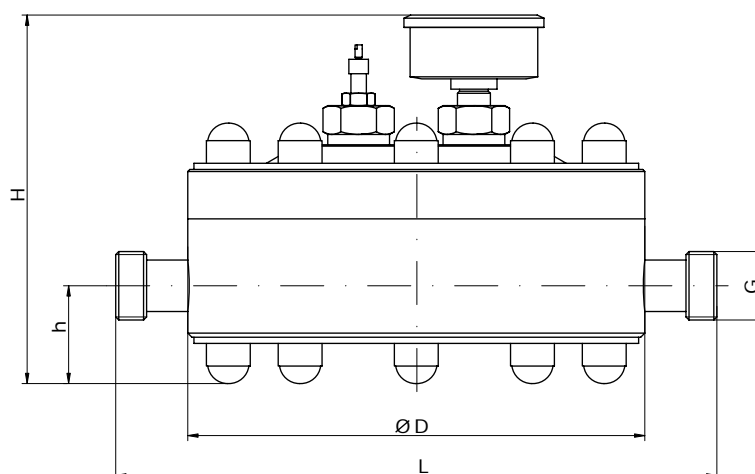
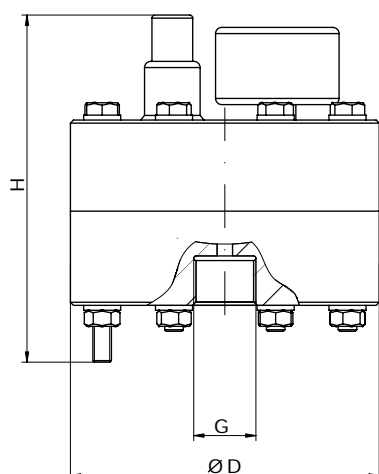

Dimensional chart

All indications in mm

Type	G	D	L	h	H	Weight kg		
						PVC-U	PP	PVDF
720.1	G 1/2	100	–	–	115	0.9	0.9	1
721.2	G 3/4	180	250	45	165	4.5	3.5	5
722.1	G 1	222	292	48	180	6.5	5	7
723.1	G 1 1/4	280	330	46	211	11.5	8	13

Order information

Diaphragm-pulsation damper

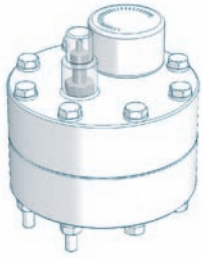

Basic design:

- Manometer d 40, 0-16 bar, plastic housing, measuring system copper alloy, filling valve,
- PVDF-design: upper part (not medium-contacting) made of PVC-U,
- Diaphragm: PTFE

Type	Thread connection	Material		
		PVC-U	PP	PVDF
		article-No.	article-No.	article-No.
720.1	G 1/2	37601848	37601856	Ⓞ

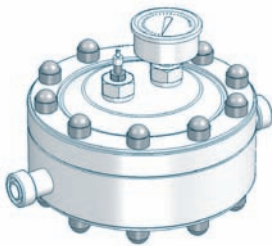

Basic design:

- Manometer d 63, 0-16 bar, sheet steel housing, measuring system copper-alloy, filling valve,
- PVDF-design: upper part (not medium-contacting) made of PVC-U,
- Diaphragm: PTFE-faced, seals: FPM

Type	Thread connection	Material		
		PVC-U	PP	PVDF
		article-No.	article-No.	article-No.
721.2	G 3/4	37602013	37602017	37602020
722.1	G 1	30100008	30100009	30100010
723.1	G 1 1/4	30100011	30100012	30100013

Options/Accessories		720.1	721.2 722.1	723.1	
Diaphragm 	PTFE	●	–	–	
	PTFE-faced	–	●	●	
	CSM	Ⓞ	Ⓞ	Ⓞ	
	FPM	Ⓞ	Ⓞ	Ⓞ	
Sealings 	FPM	–	●	●	
	EPDM	–	○	○	
	FEP-covered	–	▲	▲	
Filling pump FLP 2 	for filling device, max. 7 bar, with manometer, 2 m hose, coupling piece for air filling valve	90009396	90009396	90009396	
Connection adapter 	Thread connection: G 3/4 Connection pulsation damper: G 1/2 external	Material adapter/connection			
		PVC-U/FPM	90021733	–	–
		PVC-U/EPDM	90025079	–	–
		PP/FPM	90021734	–	–
		PP/EPDM	90024661	–	–
		PVDF/FEP-covered	Ⓞ	–	–
● = Basic design – = not available Ⓞ = on request ○ = without add. price ▲ = with add. price Art.-Nr. = available in Basic design/accessories					

720.1 – 723.1

Options/Accessories			720.1	721.2 722.1	723.1
 <p>Console for wall mounting</p> <p>PP</p>			–	–	90011722
 <p>Fixing clamp</p> <p>2 pieces per pulsation damper PP</p>	16		90010649	–	–
	25		–	90010651	–
<p>● = Basic design – = not available ⊗ = on request ○ = without add. price ▲ = with add. price Art.-Nr. = available in Basic design/accessories</p>					

3

721.1 – 724.1



721.1 to 724.1 in survey

- Easy to operate
- Low-maintenance
- Long service life
- Easy to install
- Design acc. to 97/23/EG
- High-quality materials

Infobox

- Order information [Page 3.29](#)
- Options/accessories [Page 3.29](#)
- resistance chart [Chapter 5](#)
- installation examples [Chapter 5](#)

Technical data

Type	Max. admissible operating pressure bar	Content l
721.1	50	0.14
722.1	50	0.32
723.1	50	0.86
724.1	50	1.8

Dimensional drawing

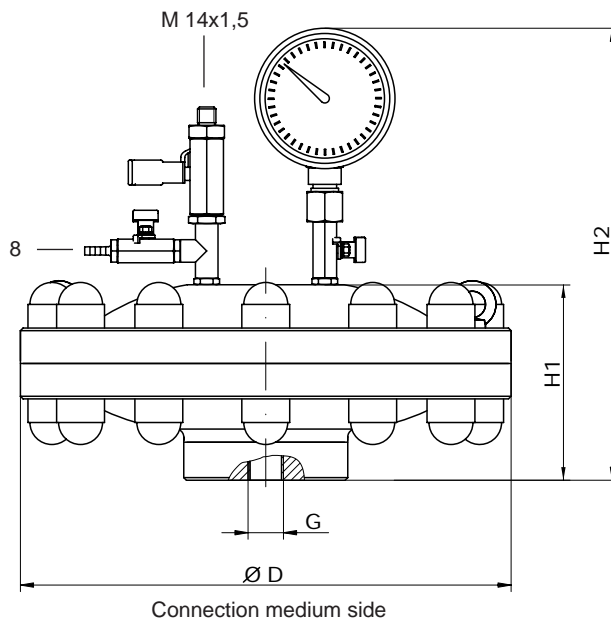

Dimensional chart

All indications in mm

Type	G	D	H1	H2	Weight kg
721.1	G 3/4	195	80	280	13
722.1	G 3/4	228	95	295	16
723.1	G 3/4	297	125	325	33
724.1	G 3/4	374	150	350	53

Order information



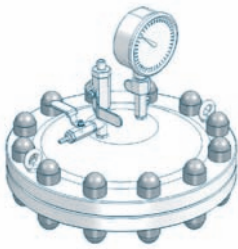

Diaphragm-pulsation damper

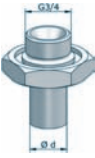
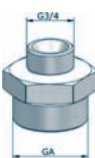

Basic design:

- Upper part (not medium-contacting) 1.4305, seal FEP-covered, diaphragm PTFE
- Filling and pressure measuring device
- Manometer glycerine-damped, d63, 0-100 bar, housing 1.4301, measuring system 1.4571

Type	Thread connection	Material 1.4571/PTFE	
		article-No.	
721.1	G 3/4	30100001	
722.1	G 3/4	30100002	
723.1	G 3/4	30100003	
724.1	G 3/4	30100004	

Options/Accessories		721.1 up to 724.1		
Transition piece - with welded end 	Design: Seals O-ring FEP-covered	d x s		
	1.4571	21,3 x 2,15	90012125	
		26,9 x 2,45	90012126	
		33,7 x 2,85	90012127	
Transition piece - with external thread 	Design: Seals O-ring FEP-covered	GA		
	1.4571	G 3/4	90023516	
		G 1 1/4	90011723	
Filling joint (for FLP2) 	1.4571	Inlet M14x1,5	Outlet M 8x1	90022488
Filling pump FLP 2 	for filling device, max. 7 bar, with manometer, 2 m hose, coupling piece for air filling valve			90009396
Console 	for wall mounting made of:	1.4301		90011238
Art.-Nr. = available in Basic design/accessories				



810.1-0,16/180 to 810.1-2,0/100 in survey

- Compact design
- Easy to operate
- Low maintenance
- Long service life
- Easy to install
- Design acc. to 97/23/EG
- High-quality materials

Infobox

- Order information [Page 3.31](#)
- Options/accessories [Page 3.31](#)
- resistance chart [Chapter 5](#)
- installation examples [Chapter 5](#)

Technical data

Type	Max. admissible operating pressure bar	Content l
810.1-0,16/180	180	0.16
810.1-0,32/160	160	0.32
810.1-0,75/140	140	0.75
810.1-2,0/100	100	2

Dimensional drawing

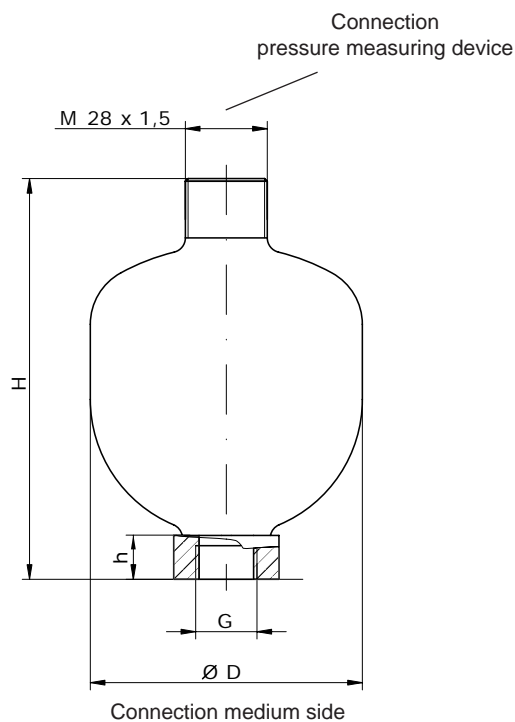

Dimensional chart

All indications in mm

Type	G	D	h	H	Weight kg
810.1-0,16/180	G 1/2	74	14	124	0.8
810.1-0,32/160	G 1/2	93	14	137	1.3
810.1-0,75/140	G 1/2	212	14	168	2.8
810.1-2,0/100	G 3/4	160	18	218	4

Order information



Diaphragm-pulsation damper



Basic design

- Connection: internal thread

Type	Thread connection	Material		
		1.4571/Butyl article-No.	1.4571/FPM article-No.	
810.1-0,16/180	G 1/2	90008811	90009498	
810.1-0,32/160	G 1/2	90010409	90010983	
810.1-0,75/140	G 1/2	37600313	37600148	
810.1-2,0/100	G 3/4	37600314	37600149	

Options/Accessories		810.1-0,16/180 up to 810.1-2,0/100	
Filling and pressure measuring devices 	Design: removable manometer d63, plastic housing, measuring system copper-alloy, 2,5 m filling hose, connection M14x1,5		
	0 - 25 bar		37601674
	0 - 100 bar		37601673
	0 - 250 bar		30066005
Filling and pressure measuring devices 	Design: up to max. 10 bar manometer d63, 0-16 bar, sheet steel housing, measuring system copper-alloy,		
	Plastic design		37600675
	Stainless steel design		37602375
	Manometer glycerine damped, housing 1.4301	measuring system copper-alloy measuring system 1.4571	▲ ▲
Filling pump FLP 2 	for filling device, max. 7 bar, with manometer, 2 m hose, coupling piece for air filling valve (optional to filling and pressure measuring device up to 10 bar)		90009396
Max. admissible operating pressure of the diaphragm pulsation damper = max. admissible operating pressure of the filling device and manometer.			
Art.-Nr. = available in Basic design/accessories		▲ = with add. price	

Suction lances with level switch Type		max. flow quantity	Page
	SL-02	up to 200 l/h	3.34
	SL-11.1 / SL-12.1	up to 35 l/h	3.36
	S-03	up to 200 l/h	3.38
	S-04	up to 570 l/h	3.40

Suction lances without level switch Type		max. flow quantity	Page
	S-01 (plastic)	up to 1500 l/h	3.42
	S-01 (stainless steel)	up to 1500 l/h	3.44

SL-02



SL-02 in survey

- Compact and robust design
- Easy to operate
- Maintenance free
- Safe
- Hardly any wear and tear
- High-quality materials
- 1- or 2-stage level monitoring
- Flexible connection possibilities

Infobox

- Order information [Page 3.35](#)
- Options/accessories [Page 3.35](#)
- resistance chart [Chapter 5](#)
- installation examples [Chapter 5](#)

Technical data

Type	Switching voltage V / AC/DC	Switching current A	Rupturing capacity		Max. flow rate l/h	Max. pump stroke value cm ³	Max. viscosity of the medium mPas	Min. density of the medium kg/dm ³
			W	VA				
SL-02	max. 48	max. 0.5	10	12	200	20	100	1

Dimensional drawing

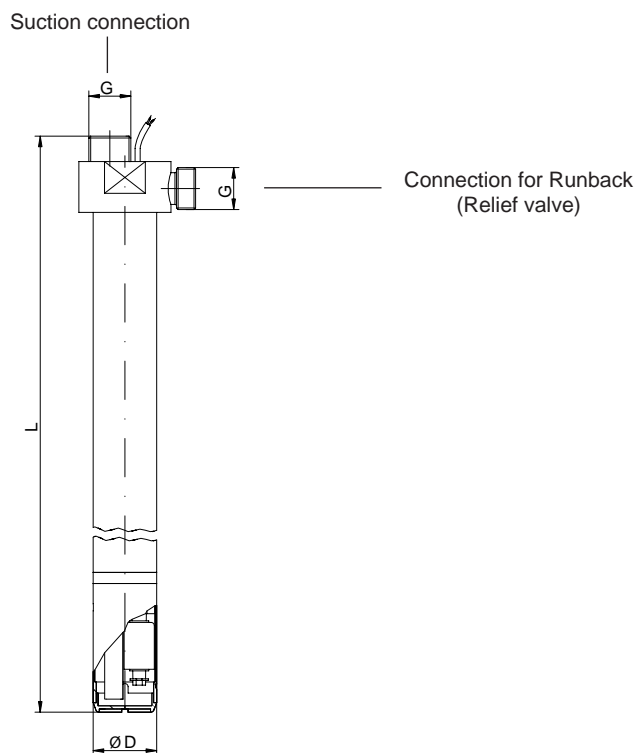

Dimensional chart

All indications in mm

Type	G	D	L
SL-02	G 3/4	40	630
SL-02	G 3/4	40	1000
SL-02	G 3/4	40	1200

3

Order information



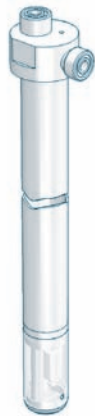

Suction lance



Basic design:

- Materials:
- PVC-U
- Foot valve: PVDF-FRP
- Valve seal and ball: PTFE
- Suction basket and level switch: PP
- Connection seal: FPM
- Level switch one-stage, closing or opening when floating down
- Length of cable: min. 3 m
- Free cable ends

Type	Thread connection	L	Material	
			PVC-U/FPM	article-No.
SL-02	G 3/4	630	30058007	
SL-02	G 3/4	1,000	30058008	
SL-02	G 3/4	1,200	37600264	

Options/Accessories		SL-02	x
Level switch 2-stage 	Level switch 2-stage design „closing when floating down“	▲	
Special length		▲	
Connection cable 	App. 3m with connection plug M8	○	
	App. 3m with connection plug M12	○	
Connection sealings 	FPM	●	
	EPDM	○	
	FEP-covered	▲	
Barrel connection adapter 	for external thread G=S65 x 5 DIN2781	PP/FPM	90011762
		PP/EPDM	90011763
	for internal thread G=2 fine thread steel cask DIN-ISO 228-1	PP/FPM	90011770
		PP/EPDM	90011771
	for internal thread G=v. empty/tri-sure BCS 56x4 EN12708	PP/FPM	90011768
		PP/EPDM	90011769
	for external thread G=DIN51	PP/FPM	90011766
		PP/EPDM	90011767
	for wall bushing G=2, wall thickness S=max. 6mm	PP/FPM	90011772
		PP/EPDM	90011773
	More adapter on request		

● = Basic design

▲ = with add. price

○ = without add. price

Art.-Nr. = available in Basic design/ accessories



SL-11.1 / SL-12.1 in survey

- Compact design
- Safe
- Height-adjustable
- 1- or 2-stage level monitoring
- Flexible connection possibilities
- Maintenance-free
- Hardly any wear and tear
- Easy to operate
- High-quality materials

Infobox

- Order information [Page 3.37](#)
- Options/accessories [Page 3.37](#)
- resistance chart [Chapter 5](#)
- installation examples [Chapter 5](#)

Technical data

Type	Switching voltage V / AC/DC	Switching current A	Rupturing capacity		Max. flow rate l/h	Max. viscosity of the medium mPas	Min. density of the medium kg/dm ³
			W	VA			
SL-11.1	max. 50	0.5	10	10	35*	50	1
SL-12.1	max. 50	0.5	10	10	35*	50	1

*Max. flow rate: up to 14 l/h with hose screwing 4/6
up to 35 l/h with hose screwing 6/12

Dimensional drawing

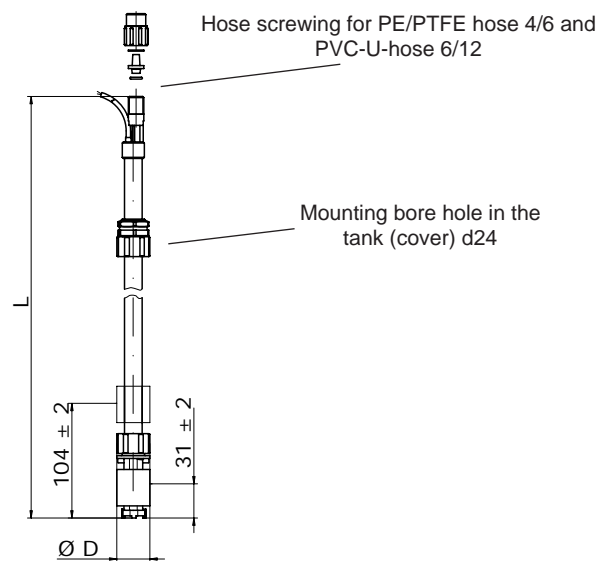

Dimensional chart

All indications in mm

Type	D	L
SL-11.1	30	600
SL-11.1	30	1000
SL-12.1	30	600
SL-12.1	30	1000

Order information

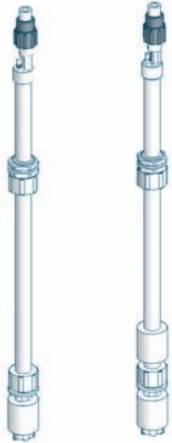

Suction lance



Basic design:

- Materials:
- PVC-U or PP
- Foot valve: PVC -U or PP
- Seals: FPM and EPDM (both materials are used)
- Valve ball: glass
- Internal hose: PE
- Level switch: PP
- Level switch one or two-stage, closing when floating down
- Length of cable: min. 2 m
- Free cable ends
- Connection parts: hose screwing for PTFE/PE-hose 4/6 and PVC-U-hose 6/12

Type	L	Level switch	Material	
			PVC-U/FPM-EPDM	PP/FPM-EPDM
			article-No.	article-No.
SL-11.1	600	1-stage	37602034	37602040
SL-11.1	1000	1-stage	37602035	37602041
SL-12.1	600	2-stage	37602066	37602072
SL-12.1	1000	2-stage	37602067	37602073

Options/Accessories		SL-11.1	SL-12.1	x
Switch function 	closing when floating down	●		
	opening when floating down	○		
Valve balls 	Glass	●		
	PTFE	▲		
Connection cable 	2 m with plug M 8	▲		
	2 m with plug M 12	▲		
Adapter, gas-tight	PVC-U / EPDM	▲		
	PVC-U / FPM	▲		
	PP / EPDM	▲		
	PP / FPM	▲		

● = Basic design ▲ = with add. price ○ = without add. price

S-03



S-03 in survey

- Compact and robust design
- Easy to operate
- Maintenance-free
- Safe
- Hardly any wear and tear
- High-quality materials
- 1-stage level monitoring
- Flexible connection possibilities

Infobox

- Order information [Page 3.39](#)
- Options/accessories [Page 3.39](#)
- resistance chart [Chapter 5](#)
- installation examples [Chapter 5](#)

Technical data

Type	Switching voltage V / AC/DC	Switching current A	Rupturing capacity		Max. flow rate l/h	Max. pump stroke value cm ³	Max. viscosity of the medium mPas	Min. density of the medium kg/dm ³
			W	VA				
S-03	max. 48	max. 0.5	10	12	200	20	100	1

Dimensional drawing

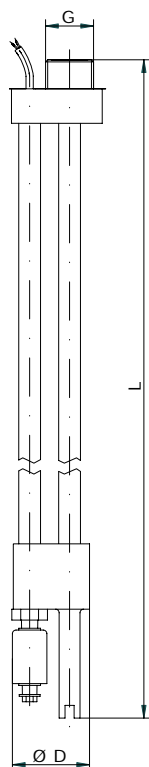

Dimensional chart

All indications in mm

Type	G	D	L
S-03	G 3/4	44	630
S-03	G 3/4	44	1000
S-03	G 3/4	44	1200

Order information



Suction lance



Basic design:

- Materials:
- PVC-U
- Foot valve: PVC-U
- Seals: FPM or EPDM
- Ball: glass
- Level switch: PP
- Level switch one-stage, closing when floating down
- Length of cable: min. 3 m
- Free cable ends

Type	Thread connection	L	Level switch	Material	
				PVC-U/EPDM article-No.	PVC-U/FPM article-No.
S-03	G 3/4	630	1-stage	37602282	37600665
S-03	G 3/4	1000	1-stage	30091061	30091060
S-03	G 3/4	1200	1-stage	30091063	30091062

Options/Accessories		S-03	x
Connection cable 	App. 3m with connection plug M8	▲	
	App. 3m with connection plug M12	▲	
Valve balls 	Glass	●	
	1.4401	○	
	PTFE	▲	

● = Basic design ▲ = with add. price ○ = without add. price

S-04



S-04 in survey

- Compact and robust design
- Easy to operate
- Maintenance-free
- Safe
- Hardly any wear and tear
- High-quality materials
- 1-stage level monitoring
- Flexible connection possibilities

Infobox

- Order information [Page 3.41](#)
- Options/accessories [Page 3.41](#)
- resistance chart [Chapter 5](#)
- installation examples [Chapter 5](#)

Technical data

Type	Switching voltage V / AC/DC	Switching current A	Rupturing capacity		Max. flow rate l/h	Max. viscosity of the medium mPas	Min. density of the medium kg/dm ³
			W	VA			
S-04	48	0.5	10	12	570	100	1

Dimensional drawing

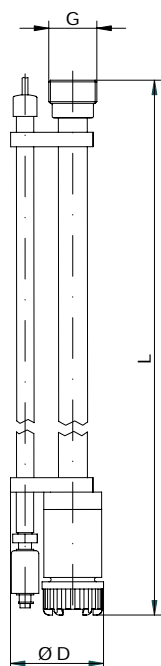

Dimensional chart

All indications in mm

Type	G	D	L
S-04	G 1	66	630
S-04	G 1	66	1000
S-04	G 1	66	1200

Order information



Suction lance



Basic design:

- Materials:
- PVC-U
- Foot valve: PVC-U
- Seals: FPM or EPDM
- Ball: glass
- Level switch: PP
- Level switch one-stage, closing when floating down
- Length of cable: min. 3 m
- Free cable ends

Type	Thread connection	L	Level switch	Material	
				PVC-U/EPDM article-No.	PVC-U/FPM article-No.
S-04	G 1	630	1-stage	37600991	37602283
S-04	G 1	1000	1-stage	30091068	30091069
S-04	G 1	1200	1-stage	30091071	30091070

Options/Accessories		S-04	x
Connection cable 	App. 3m with connection plug M8	▲	
	App. 3m with connection plug M12	▲	
Valve balls 	Glass	●	
	1.4401	○	
	PTFE	▲	

● = Basic design ▲ = with add. price ○ = without add. price

Suction lance

without level switch / Plastic design
Flow rate up to 1500 l/h

S-01



S-01 in survey

- Compact and robust design
- Maintenance-free
- Hardly any wear and tear
- Easy to operate
- High-quality materials

Infobox

Order information [Page 3.43](#)
Options/accessories [Page 3.43](#)
resistance chart [Chapter 5](#)
installation examples [Chapter 5](#)

Dimensional drawing

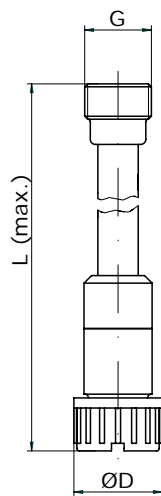

Dimensional chart

All indications in mm

Type	DN	G	D			L (max.)
			PVC-U	PP	PVDF	
S-01	10	G 3/4	38	35	35	1500
S-01	15	G 3/4	46	–	–	1500
S-01	15	G 1	46	–	–	1500
S-01	20	G 1	56	52	52	1500
S-01	20	G 1 1/4	56	52	52	1500

Order information

Suction lance



Basic design:

- Materials: PVC-U/PP/PVDF
- Valve balls:
- with DN10: glass
- with DN15: (PVC-U) PVC-U
- with DN15: (PP/PVDF) glass
- with DN20: (PVC-U) PVC-U
- with DN20: (PP/PVDF) glass

Type	Nominal width DN	Connection external thread	Material			
			PVC-U/EPDM	PVC-U/FPM	PP/PP-FRP/FPM	PVDF/PVDF-FRP/FPM
			article-No.	article-No.	article-No.	article-No.
S-01	10	G 3/4	30091005	37600339	30091026	30091038
S-01	15	G 3/4	30091010	37600349	–	–
S-01	15	G 1	30091011	37600352	–	–
S-01	20	G 1	30091018	37600360	30091030	30091042
S-01	20	G 1 1/4	30091019	37600369	30091031	30091043

Options/Accessories			S-01	✕
Valve balls	DN10	1..4401	○	
		PTFE	▲	
	DN15	1..4401	▲	
		PTFE	▲	
	DN20	1.4401	▲	
		PTFE	▲	

▲ = with add. price ○ = without add. price

Suction lance

without level switch / Stainless steel design
Flow rate up to 1500 l/h

S-01



S-01 in survey

- Compact and robust design
- Maintenance-free
- Hardly any wear and tear
- Easy to operate
- High-quality materials

Infobox

Order information [Page 3.45](#)
Options/accessories [Page 3.45](#)
resistance chart [Chapter 5](#)
installation examples [Chapter 5](#)

Dimensional drawing

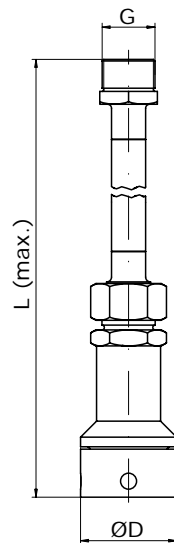

Dimensional chart

All indications in mm

Type	DN	G	D	L
S-01	10	G 3/4	60	1500
S-01	15	G 3/4	60	1500
S-01	15	G 1	60	1500
S-01	20	G 1	60	1500
S-01	20	G 1 1/4	60	1500

Suction lance









Basic design:

- Material: 1.4571
- Valve balls: 1.4401
- Sealings: EPDM

Type	Nominal width DN	Connection external thread	Material	
			1.4571/EPDM	article-No.
S-01	10	G 3/4		37600379
S-01	15	G 3/4		37600382
S-01	15	G 1		37600385
S-01	20	G 1		37600391
S-01	20	G 1 1/4		37600394

Options/Accessories		S-01	x	
Sealings	DN10	FPM	○	
		EPDM	●	
		FEP-cov.	▲	
	DN15	FPM	○	
		EPDM	●	
		FEP-cov.	▲	
	DN20	FPM	○	
		EPDM	●	
		FEP-cov.	▲	
● = Basic design		▲ = with add. price	○ = without add. price	

Check valves / Injection fittings	Type	max. flow rate	Page	
	Check valves	661.2 ... 663.2	up to 1500 l/h	3.48
	Check valves for Suspension	642.S ... 647.S	up to 6000 l/h	3.52
	Dosing valves	691.1 ... 693.1	up to 1500 l/h	3.54
	Dosing valves	681.1 ... 687.1	up to 6000 l/h	3.58
	Injection fittings	8061.1 ... 8063.1	up to 1500 l/h	3.60
	Vent valve, manual	8152	up to 190 l/h	3.62



661.2 - 663.2 in survey

- Compact design
- Easy to mount
- Maintenance free
- Hardly any wear and tear
- High-quality materials

Infobox

- Order information [Page 3.49](#)
- Options/accessories [Page 3.49](#)
- resistance chart [Chapter 5](#)
- installation examples [Chapter 5](#)

Technical data

Type	Nominal width DN	Max. admissible operating pressure bar	
		Plastics	1.4571
661.2	8	10	63
662.2	15	–	40
663.2	20	10	25

Dimensional drawing

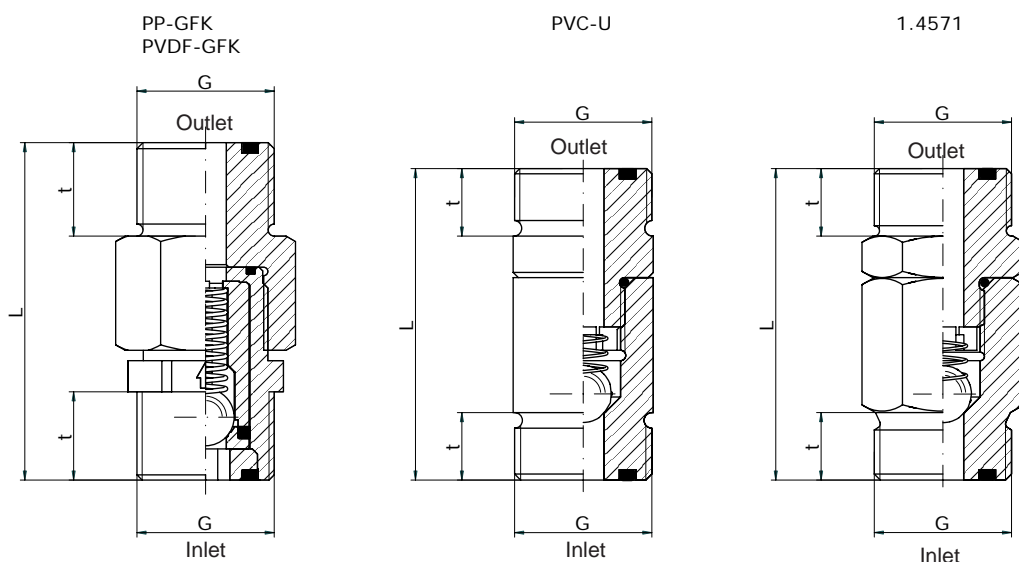

Dimensional chart

All indications in mm

Type	G	L			t		
		PVC-U	PP-FRP / PVDF-FRP	1.4571	PVC-U	PP-FRP / PVDF-FRP	1.4571
661.2	G 3/4	60	65	60	13	18	13
662.2	G 1	–	–	104	–	–	17
663.2	G 1 1/4	–	60	119	–	25	20

not spring-loaded: vertical installation
Weights on request

Order information
Check valve

Basic design:

- Valve body: PVC-U
- Valve ball: Glass
- Valve seals: FPM

Type	Thread connection	Material PVC-U	
		article-No.	
661.2	G 3/4	37601894	

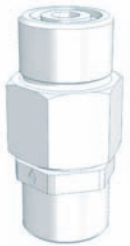
Basic design:

- Valve body:
- Type 661.2 made of PP/PP-FRP or PVDF/PVDF-FRP
- Type 663.2 made of PP-FRP or PVDF-FRP
- Valve ball: Glass
- Valve seal: FPM

Type	Thread connection	Material			
		PP/PP-FRP article-No.	PVDF/PVDF-FRP article-No.	PP-FRP article-No.	PVDF-FRP article-No.
661.2	G 3/4	30084106	30084109	–	–
663.2	G 1 1/4	–	–	30084130	30084135

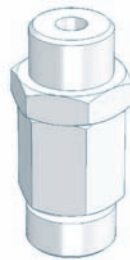
Basic design:

- Valve body: 1.4571
- Valve ball: 1.4401
- Valve seals: EPDM



Type	Thread connection	Material 1.4571	
		article-No.	
661.2	G 3/4	37600154	
662.2	G 1	37600155	
663.2	G 1 1/4	37600156	

Options/Accessories

Options/Accessories		661.2	662.2	663.2	
 Valve balls	PVC-U	Glass	●	–	
		PTFE	▲	–	
		1.4401	○	–	
	PP/PP-FRP	Glass	●	–	●
		PTFE	▲	–	▲
		1.4401	○	–	○
	PVDF/PVDF-FRP	Glass	●	–	●
		PTFE	▲	–	▲
		1.4401	○	–	○
	1.4571	1.4401	●	●	●
		PTFE*	▲	▲	▲

● = Basic design ▲ = with add. price ○ = without add. price – = nicht lieferbar

*Operating pressure with PTFE-ball max. 10 bar

Options/Accessories			661.2	x	662.2	x	663.2	x
Valve sealings 	PVC-U	FPM	●		–		–	
		FEP-covered	▲		–		–	
		EPDM	○		–		–	
	PP/PP-FRP	FPM	●		–		●	
		FEP-covered	▲		–		▲	
		EPDM	○		–		○	
	PVDF/PVDF-FRP	FPM	●		–		●	
		FEP-covered	▲		–		▲	
		EPDM	○		–		○	
	1.4571	FPM	○		○		○	
		FEP-covered	▲		▲		▲	
		EPDM	●		●		●	
Spring load 	Spring made of Hastelloy C4, opening pressure 0,2bar, Valve body material PVC	▲		▲		▲		
	Spring made of Hastelloy C4, opening pressure 0,5bar or 1,5 bar, Valve body material PP-FRP/PVDF-FRP	▲		▲		▲		
	Spring made of Hastelloy C4, opening pressure 0,2bar, Valve body material 1.4571	▲		▲		▲		
● = Basic design ▲ = with add. price ○ = without add. price – = nicht lieferbar								

3

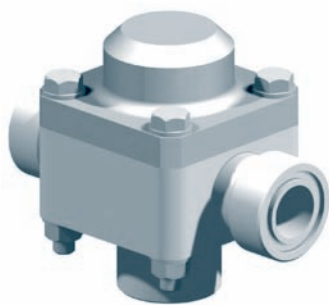

642.S - 647.S in survey

- Compact design
- Easy to mount
- Maintenance free
- High-quality materials

Infobox

- Order information [Page 3.53](#)
- Options/accessories [Page 3.53](#)
- resistance chart [Chapter 5](#)
- installation examples [Chapter 5](#)

Technical data

Type	Nominal width	Max. admissible operating pressure
	DN	
642.S	15	10
643.S	20	10
644.S	25	10
645.S	32	10
646.S	40	10
647.S	50	10

Dimensional drawing

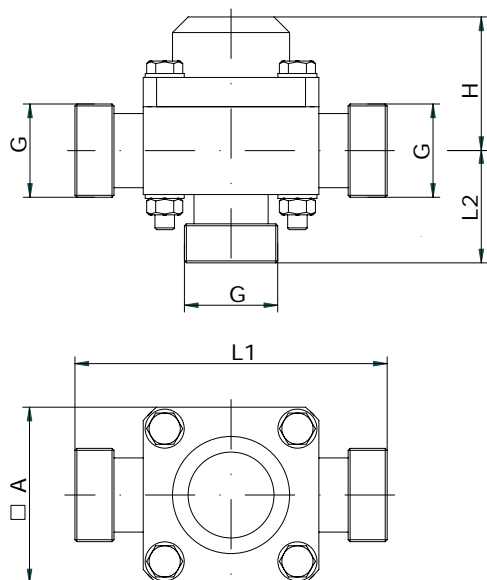

Dimensional chart

All indications in mm

Type	G	L1	L2	h	H	A
642.S	G 1	115	45	17	48	72
643.S	G 1 1/4	130	47	18	53	80
644.S	G 1 1/2	160	58	23	68	90
645.S	G 2	210	105	38	98	100
646.S	G 2 1/4	230	115	40	108	115
647.S	G 2 3/4	250	125	48	128	140

Weights on request

Order information

Check valve for suspension

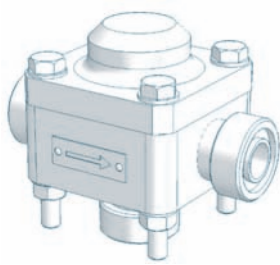

Basic design:

- Connection seal: FPM
- Valve balls:
- Type 642 - 643 ball: Glass
- Type 644 - 646 ball: PTFE
- Type 647 ball: rubberized steel

Type	Thread connection	Material PVC-U	
		article-No.	
642.S	G 1	37600207	
643.S	G 1 1/4	37600209	
644.S	G 1 1/2	37600211	
645.S	G 2	37600213	
646.S	G 2 1/4	37600215	
647.S	G 2 3/4	37600217	

Options/Accessories		642.S up to 647.S	x
Sealing for connection thread 	FPM	●	
	EPDM	○	

● = Basic design ○ = without add. price



691.1 to 693.1 in survey

- Compact design
- Easy to mount
- Maintenance free
- Hardly any wear and tear
- Any fitting position
- High-quality materials

Infobox

- Order information [Page 3.55](#)
- Options/accessories [Page 3.55](#)
- resistance chart [Chapter 5](#)
- installation examples [Chapter 5](#)

Technical data

Type	Nominal width DN	Max. admissible operating pressure bar		Opening pressure bar	
		plastics	1.4571	PVC-U/1.4571	PP-FRP/PVDF-FRP
691.1	8	10	63	1	0.5
692.1	15	–	40	1	0.5
693.1	20	10	25	1	0.5

Dimensional drawing

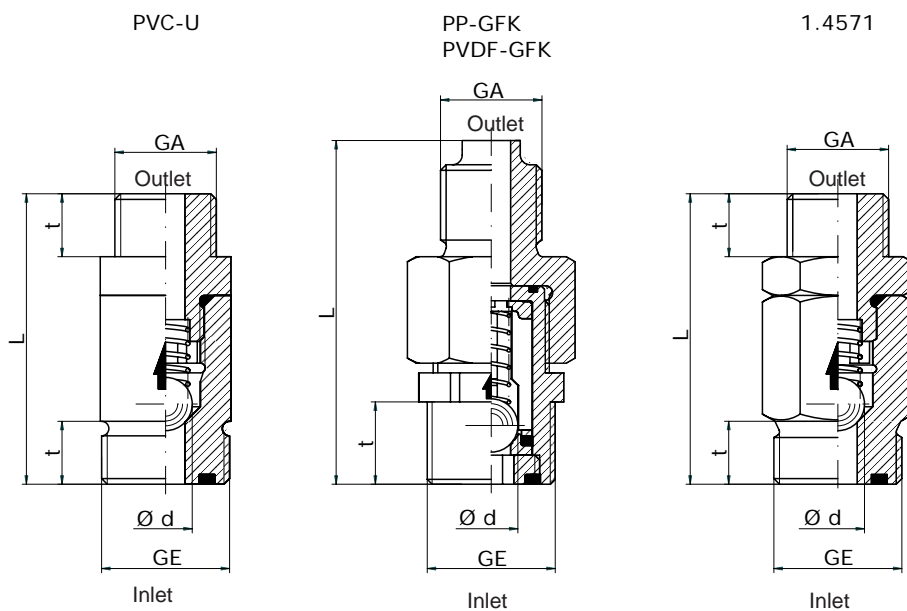

Dimensional chart

All indications in mm

Type	GE	GA	d			L			t		
			PVC-U	PP-FRP/ PVDF-FRP	1.4571	PVC-U	PP-FRP / PVDF-FRP	1.4571	PVC-U	PP-FRP / PVDF-FRP	1.4571
691.1	G 3/4	R 1/2	11	12	11	60	71	60	13	18	13
692.1	G 1	R 1	–	–	25	–	–	104	–	–	17
693.1	G 1 1/4	R 1 1/4	–	25	25	–	101	119	–	25	20

Weights on request

Order information
Dosing valves

Basic design:

- Valve body: PVC-U
- Valve balls: Glass
- Valve seals: FPM
- Spring: Hastelloy C4

Type	Thread connection Inlet - Outlet	Material PVC-U	
		article-No.	
691.1	G 3/4 - R 1/2	37600586	

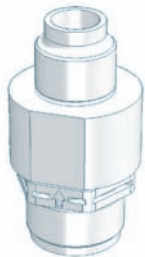
Basic design:

- Valve body:
- Type 691.1 made of PP/PP-FRP or PVDF/PVDF-FRP
- Type 693.1 made of PP-FRP or PVDF-FRP
- Valve balls: glass
- Valve seals: FPM
- Spring: Hastelloy C4

Type	Thread connection Inlet - Outlet	Material			
		PP/PP-FRP article-No.	PVDF/PVDF-FRP article-No.	PP-FRP article-No.	PVDF-FRP article-No.
691.1	G 3/4 - R 1/2	30072005	30072011	–	–
693.1	G 1 1/4 - R 1 1/4	–	–	30072017	30072023

Basic design:

- Valve body: 1.4571
- Valve ball: 1.4401
- Valve seal: FPM
- Spring: Hastelloy C4



Type	Thread connection Inlet - Outlet	Material 1.4571	
		article-No.	
691.1	G 3/4 - R 1/2	37600222	
692.1	G 1 - R 1	37600224	
693.1	G 1 1/4 - R 1 1/4	37600226	

Options/Accessories

		691.1	692.1	693.1	
Valve balls 	PVC-U	Glass	●	–	
		PTFE	▲	–	
		1.4401	○	–	
	PP/PP-FRP	Glass	●	–	●
		PTFE	▲	–	▲
		1.4401	○	–	○
	PVDF/PVDF-FRP	Glass	●	–	●
		PTFE	▲	–	▲
		1.4401	○	–	○
	1.4571	PTFE*	▲	▲	▲
		1.4401	●	●	●

● = Basic design ▲ = with add. price ○ = without add. price

*Operating pressure with PTFE-ball 10 bar

Options/Accessories			691.1	x	692.1	x	693.1	x
Valve sealings 	PVC-U	FPM	●		–		–	
		FEP-covered	▲		–		–	
		EPDM	○		–		–	
	PP/PP-FRP	FPM	●		–		●	
		FEP-covered	▲		–		▲	
		EPDM	○		–		○	
	PVDF/PVDF-FRP	FPM	●		–		●	
		FEP-covered	▲		–		▲	
		EPDM	○		–		○	
	1.4571	FPM	●		●		●	
		FEP-covered	▲		▲		▲	
		EPDM	○		○		○	
Spring load 	Spring made of Hastelloy C4, opening pressure 1bar, Valve body material PVC-U		●		–		–	
	Spring made of Hastelloy C4, opening pressure 1bar, Valve body material 1.4571		●		●		●	
	Spring made of Hastelloy C4, opening pressure 0,5bar, Valve body material PP/PP-FRP, PVDF/PVDF-FRP		●		●		●	
	Spring made of Hastelloy C4, opening pressure 1,5bar, Valve body material PP/PP-FRP, PVDF/PVDF-FRP		○		○		○	
● = Basic design ▲ = with add. price ○ = without add. price								



681.1 - 687.1 in survey

- Compact design
- Easy to mount
- Maintenance-free
- Hardly any wear and tear
- Any fitting position
- High-quality materials
- Soft seated

Infobox

- Order information [Page 3.59](#)
- Options/accessories [Page 3.59](#)
- resistance chart [Chapter 5](#)
- installation examples [Chapter 5](#)

Technical data

Type	Nominal width	Max. admissible operating pressure
	DN	bar
681.1	10	10
682.1	15	10
683.1	20	10
684.1	25	10
685.1	32	10
686.1	40	10
687.1	50	10

Dimensional drawing

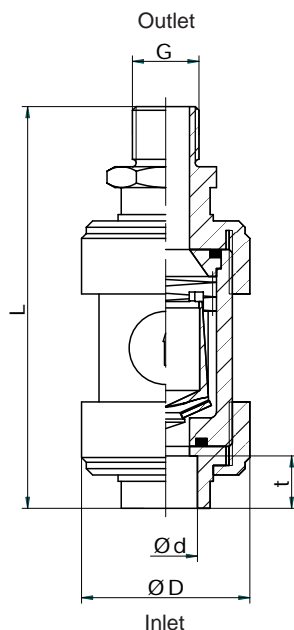

Dimensional chart

All indications in mm

Type	G	d	D	L		t	
				PVC-U	PP/PVDF	PVC-U	PP/PVDF
681.1	R 1/2	16	53	125.5	118	16.5	13
682.1	R 1/2	20	53	125.5	123.5	16.5	14.5
683.1	R 3/4	25	63	142.5	142	19.5	16
684.1	R 1	32	71	156.5	156	22.5	18
685.1	R 1 1/4	40	86	176.5	177.5	26.5	20.5
686.1	R 1 1/2	50	101	201.5	203.5	31.5	23.5
687.1	R 2	63	118	236.5	240.5	38.5	27.5

Weights on request

Order information
Dosing valves

Basic design:

- Spring: PTFE-covered
- Connection:
- Inlet:
- with PVC-U with glued bushing
- with PP and PVDF with welded bushing
- Outlet: Thread

Type	Thread connection Outlet	Material					
		PVC-U/EPDM	PVC-U/FPM	PP/EPDM	PP/FPM	PVDF/FPM	
		article-No.	article-No.	article-No.	article-No.	article-No.	
681.1	R 1/2	37600855	37600701	37600867	37600868	37601375	
682.1	R 1/2	37600856	37600556	37600869	37600870	37601376	
683.1	R 3/4	37600857	37600858	37600878	37600879	37601411	
684.1	R 1	37600859	37600860	37600880	37600881	37601412	
685.1	R 1 1/4	37600861	37600862	37600882	37600883	37601413	
686.1	R 1 1/2	37600863	37600864	37600884	37600885	37601414	
687.1	R 2	37600865	37600866	37600886	37600887	37601415	

Options/Accessories		681.1 up to 687.1
Spring for  Opening pressure 1,5 bar	PVC-U	▲
	PP	▲
	PVDF	▲
▲ = with add. price		



8061.1 to 8063.1 in survey

- Easy to mount
- Injection lance for better mixing
- Maintenance-free
- Hardly any wear and tear
- Any fitting position
- High-quality materials

Infobox

- Order information [Page 3.61](#)
- Options/accessories [Page 3.61](#)
- resistance chart [Chapter 5](#)
- installation examples [Chapter 5](#)

Technical data

Type	Nominal width DN	Max. admissible operating pressure bar	Opening pressure bar
8061.1	10	10	0.05
8062.1	15	10	0.05
8063.1	20	10	0.05

Dimensional drawing

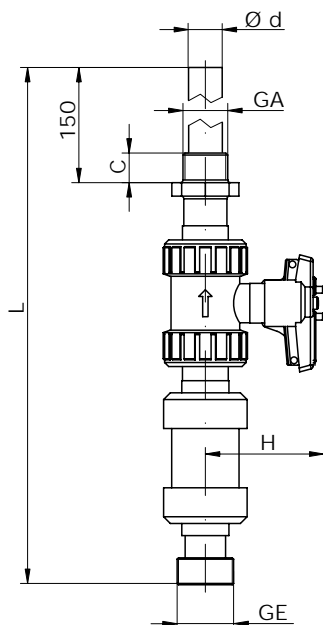

Dimensional chart

All indications in mm

Type	GE	GA	d	L			H	C	
				PVC-U	PP	PVDF		PVC-U	PP/PVDF
8061.1	G 3/4	R 1/2	16	390	427	438	72	17	17
8062.1	G 1	R 3/4	20	409	439	446	72	19	19
8063.1	G 1 1/4	R 1	25	447	481	486	77	22	19

Weights on request

Order information
Injection fitting

Basic design

- Cone type check valve
- Shut-off ball cock
- Injection lance (l=150mm)

Type	Thread connection Inlet - Outlet	Material					
		PVC-U/EPDM article-No.	PVC-U/FPM article-No.	PP/EPDM article-No.	PP/FPM article-No.	PVDF/FPM article-No.	
8061.1	G 3/4 - R 1/2	37602105	37602106	37602107	37602108	37602109	
8062.1	G 1 - R 1	37602110	37602111	37602112	37602113	37602114	
8063.1	G 1 1/4 - R 1 1/4	37602115	37602116	37602117	37602118	37602119	

Options/Accessories		8061.1 up to 8063.1	
 Spring for Opening pressure 1,5 bar	PVC-U	▲	✕
	PP	▲	
	PVDF	▲	
▲ = with add. price			

8152

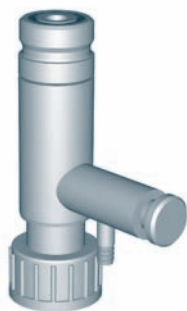

8152 in survey

- Compact design
- Easy to mount
- Maintenance-free
- Hardly any wear and tear
- High-quality materials

Infobox

Order information [Page 3.63](#)
Options/accessories [Page 3.63](#)
resistance chart [Chapter 5](#)
installation examples [Chapter 5](#)

Technical data

Type	Nominal width DN	Max. admissible operating pressure bar	Max. pump stroke value cm ³
8152	8	10	20

Dimensional drawing

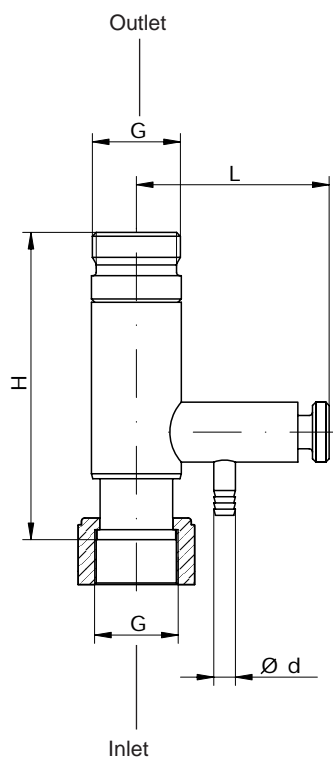

Dimensional chart



All indications in mm

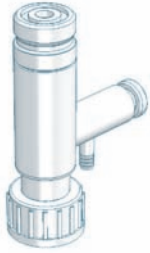

Type	G	d	L	H	Weight kg
8152	G 3/4	6,5	60	86	0.08

Order information
Vent valve, manual

Basic design:

- Ball: Glass
- Seal: FPM
- Connection: ventilating joint: hose nuzzle d=6,5

Type	Thread connection	Material		
		PVC-U	PP	PVDF
		article-No.	article-No.	article-No.
8152	G 3/4	37600270	37600272	37602796

Options/Accessories		8152	✕
Valve balls 	Glass	●	
	1.4401	○	
	PTFE	▲	
Valve sealings 	FPM	●	
	EPDM	○	
	FEP-covered	▲	
● = Basic design ○ = without add. price ▲ = with add. price			

Shut-off valves	Type	max. admissible Operation pressure	Page	
	Two way - ball cock	8001 ... 8009	up to 10 bar	3.66
	Two way - ball cock	8001.1 ... 8007.1	up to 63 bar	3.68



8001 to 8009 in survey

- Lockable
- Radially incorporable and dismantlable
- Any direction of flow
- Full sectional area of flow
- Double shaft seal
- High-quality materials

Infobox

Order information [Page 3.67](#)
 Options/accessories [Page 3.67](#)
 resistance chart [Chapter 5](#)
 installation examples [Chapter 5](#)

Technical data

Type	Nominal width DN	Max. admissible operating pressure bar	
		PP	PVC-U/PVDF
8001	10	10	10
8002	15	10	10
8003	20	10	10
8004	25	10	10
8005	32	10	10
8006	40	10	10
8007	50	10	10
8008	65	10	10
8009	80	6	10

Dimensional drawing

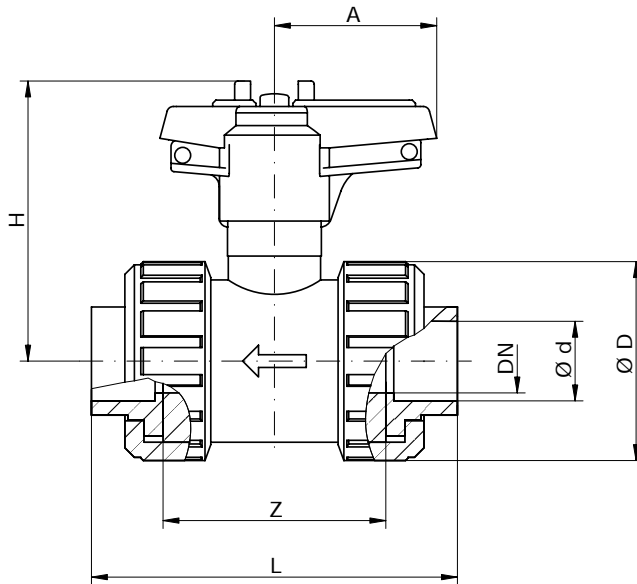

Dimensional chart

All indications in mm

Type	DN	d	D			L			H		Z		
			PVC-U	PP	PVDF	PVC-U	PP	PVDF	PVC-U	PP/PVDF	PVC-U	PP/PVDF	
8001	10	16	53	52.5	51.8	100.5	100	99	72	71.5	40	62	62
8002	15	20	53	52.5	51.8	100.5	99.5	99	72	71.5	40	62	62
8003	20	25	63	62	61.5	115	113	113	78.5	77	51.5	70	69
8004	25	32	70	69.5	68.5	126	123	122	81.5	80.5	51.5	74	73
8005	32	40	85	84	83.5	143	140	139	100	98.5	64	84	83
8006	40	50	101	100	98	167	164	164	107.5	106.5	71	95	94
8007	50	63	121.5	120.5	118	198	192	192	116.5	115.5	85	109	108
8008	65	75	155	155	151	238	231	216	144	142	110	137	133
8009	80	90	188	187	183	294	285	288	163	160	132	163	160

Weights on request

Order information

Two-way ball cock

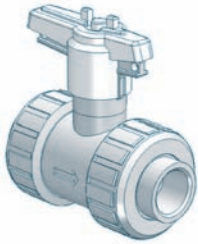

Basic design:

- Connection: PVC-U with glued bushing
- Connection: PP and PVDF with welded bushing
- Lockable

Type	DN	Connection d	Material				
			PVC-U/EPDM article-No.	PVC-U/FPM article-No.	PP/EPDM article-No.	PP/FPM article-No.	PVDF/FPM article-No.
8001	10	16	30038005	30038006	30038007	30038008	30038009
8002	15	20	30039005	30039006	30039007	30039008	30039009
8003	20	25	30040005	30040006	30040007	30040008	30040009
8004	25	32	30041005	30041006	30041007	30041008	30041009
8005	32	40	30042005	30042006	30042007	30042008	30042009
8006	40	50	30043005	30043006	30043007	30043008	30043009
8007	50	63	30063005	30063006	30063007	30063008	30063009
8008	65	75	30068005	30068006	30068007	30068008	30068009
8009	80	90	30069005	30069006	30069007	30068008	30069009



8001.1 to 8007.1 in survey

- Lockable
- Radially incorporable and dismantable
- Any direction of flow
- Full sectional area of flow
- High-quality materials

Infobox

- Order information [Page 3.69](#)
- Options/accessories [Page 3.69](#)
- resistance chart [Chapter 5](#)
- installation examples [Chapter 5](#)

Technical data

Type	Nominal width DN	Max. admissible operating pressure bar
8001.1	10	63
8002.1	15	63
8003.1	20	63
8004.1	25	63
8005.1	32	63
8006.1	40	63
8007.1	50	63

Dimensional drawing

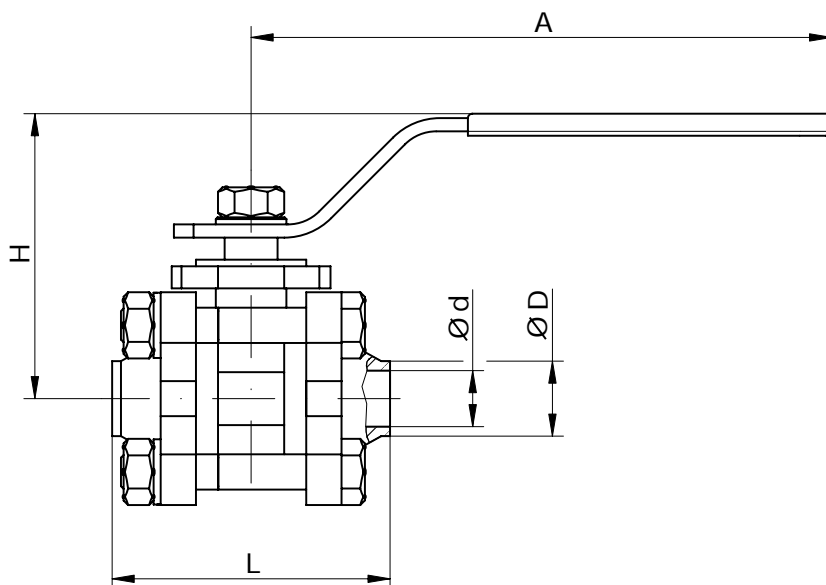

Dimensional chart

All indications in mm

Type	d	D	L	H	A	Weight kg
8001.1	12,7	18	59	51	95	0.4
8002.1	15	22	64	55	95	0.58
8003.1	20	27.5	75	59	110	0.75
8004.1	25	33.5	86	73	135	1.08
8005.1	32	44	99	78	135	1.85
8006.1	38	50	113	91	165	2.6
8007.1	50,8	61.5	132	99	165	3.94

Order information



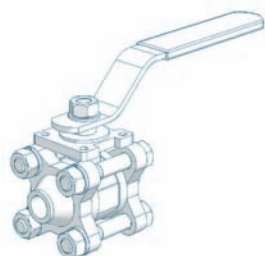



Two-way ball cock



Basic design:

- 3-part two-way ball cock
- Lockable
- Connection: welding end

Type	DN	Connection d	Material	
			1.4408 / PTFE article-No.	
8001.1	10	12,7	37601366	
8002.1	15	15	37601367	
8003.1	20	20	37601368	
8004.1	25	25	37601369	
8005.1	32	32	37601370	
8006.1	40	38	37601371	
8007.1	50	50,8	37601372	

Fittings for pump suction side	Type	max. flow quantity	Page	
	Priming aids	768.1 ... 769.1	up to 35 l/h	3.72
	Priming aids / Siphon vessels	770.2 ... 772.2	up to 4000 l/h	3.74
	Calibration pots	791.1 ... 797.1	up to 4000 l/h	3.76
	Foot valves	731 ... 736 732.2 ... 737.2 781.1 ... 783.1	up to 4000 l/h	3.78
	Line strainer	751.1 ... 757.1 752 ... 757	up to 6000 l/h	3.84
	Float valves	871 ... 877	up to 6000 l/h	3.88



768.1 to 769.1 in survey

- Compact design
- Easy to operate
- Improvement of intake characteristics of dosing pumps
- No wear and tear
- High-quality materials
- Easy to mount

Infobox

- Order information [Page 3.73](#)
- Options/accessories [Page 3.73](#)
- resistance chart [Chapter 5](#)
- installation examples [Chapter 5](#)

Technical data

Type	Nominal width DN	Max. admissible operating pressure bar	Content l
768.1	5	-1...+2	0.135
769.1	4	-1...+2	0.135

Dimensional drawing

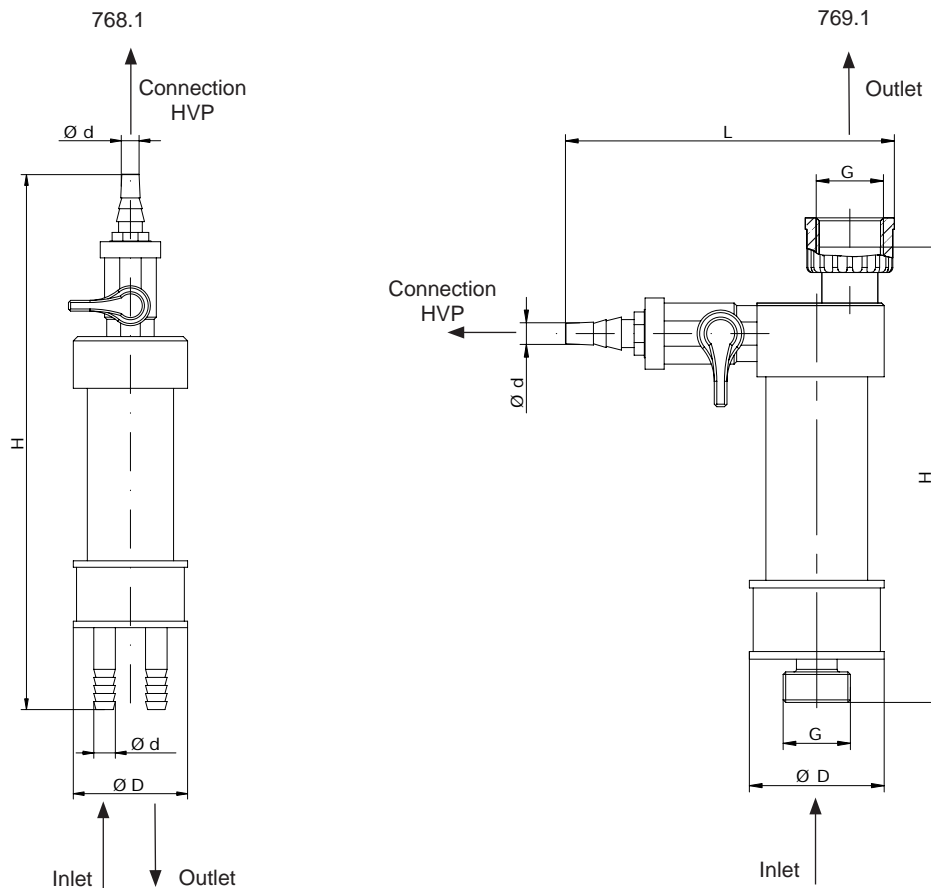

Dimensional chart

All indications in mm

Type	G	d	D	L	H
768.1	–	10	50	–	248
769.1	G 3/4	10	50	130	179

Weights on request

Order information
Suction aid

Basic design:

- incl. fixing clamp, shut-off fitting with filling-/ventilating joint, hose nozzle d=10/12

Type	Connection hose nozzle d	Material	
		PVC-U/Transp.- PVC/EPDM	PVC-U/Transp.- PVC/FPM
768.1	10	37600232	37600233

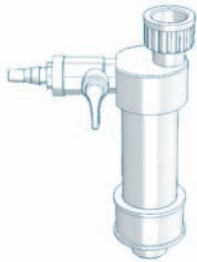
Basic design:

- Shut-off fitting with filling-/ventilating joint, hose nozzle d=10/12
- Connection: Inlet: External thread; Outlet: Internal thread

Type	Thread connection	Material	
		PVC-U/Transp.- PVC/EPDM	PVC-U/Transp.- PVC/FPM
769.1	G 3/4	37600234	37600235

Options/Accessories		768.1	769.1	x
Hand vacuum pump  Type HVP 1 incl. 1,5m hose with textile-ply PVC, d=12/21, 2 hose clamps 12-20, material: PVC/FPM			90008822	

Art.-Nr. = available in basic design/accessories



770.2 to 772.2 in survey

- Easy to operate
- Improvement of intake characteristics of dosing pumps
- No wear and tear
- High-quality materials
- Easy to mount

Infobox

- Order information [Page 3.75](#)
- Options/accessories [Page 3.75](#)
- resistance chart [Chapter 5](#)
- installation examples [Chapter 5](#)

Technical data

Type	Nominal width DN	Max. admissible operating pressure bar	Content l
770.2	15	-1...+2	2
771.2	20	-1...+2	5
772.2	40	-1...+2	10

Dimensional drawing

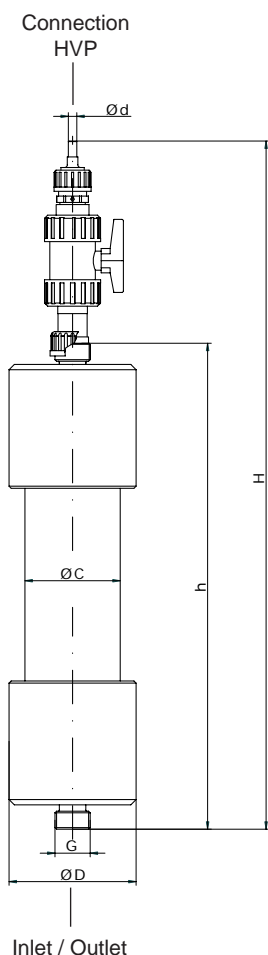

Dimensional chart

All indications in mm

Type	G	d	D	h	H	C	Weight kg
770.2	G 1	12	120	459	620	90	3.2
771.2	G 1 1/4	12	180	484	645	140	9
772.2	G 2 1/4	12	220	637	798	160	13.3

Order information



Suction aid / Siphon vessel



Basic design:

- incl. Fixing clamp (1 piece)
- Shut-off fitting with filling and ventilation joint, hose nozzle d = 12

Type	Thread connection	Material	
		Transparent-PVC/ EPDM article-No.	Transparent-PVC/ FPM article-No.
770.2	G 1	30075007	30075008
771.2	G 1 1/4	30075009	30075010
772.2	G 2 1/4	30075011	30075012

Options/Accessories	770.2 up to 772.2	x
<p>Hand vacuum pump</p>  <p>Type HVP 1 incl. 1,5m hose with textile-ply PVC, d=12/21, 2 hose clamps 12-20, material: PVC/FPM</p>	90008822	
<p>Console for wall mounting</p>  <p>PP</p>	90010913	
<p>1.4301</p>	90010911	
Wall mounted console + retaining clamp are necessary for the mounting of the suction aid / siphon vessel		
Art.-Nr. = available in basic design/accessories		



791.1 to 797.1 in survey

- Easy to operate
- Maintenance-free
- Calibration of dosing pumps
- No wear and tear
- High-quality materials
- Easy to mount

Infobox

- Order information [Page 3.77](#)
- Options/accessories [Page 3.77](#)
- resistance chart [Chapter 5](#)
- installation examples [Chapter 5](#)

Technical data

Type	Nominal width DN	Max. admissible operating pressure bar	Content l
791.1	8	-0.5...2	0.1
792.1	8	-0.5...2	0.5
793.1	10	-0.5...2	1
794.1	15	-0.5...2	2
795.1	20	-0.5...2	5
796.1	40	-0.5...2	10
797.1	40	-0.5...2	20

Dimensional drawing

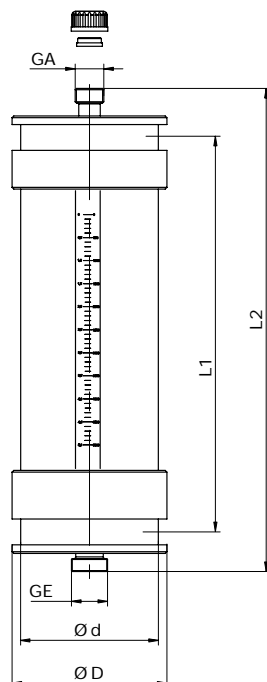

Dimensional chart

All indications in mm

Type	GE	GA	d	D	L1	L2
791.1	G 3/4	G 3/4	50	53	157	220
792.1	G 3/4	G 3/4	50	53	574	637
793.1	G 3/4	G 1	d 110	120	282	387
794.1	G 1	G 1	d 110	120	442	557
795.1	G 1 1/4	G 1	160	180	458	562
796.1	G 2 1/4	G 1	160	180	728	850
797.1	G 2 1/4	G 1	160	180	1269	1391

Weights on request

Order information
Calibration pot

Basic design:

- incl. fixing clamps (2 pcs.)
- Connection aeration: Type 791.1 and 792.1: G 3/4 with union nut and blind cap
- Connection aeration: Type 793.1 to 797.1: G 1 with union nut and blind cap
- Material: PVC-U/Transp.-PVC

Type	Thread connection GE	Material	
		PVC-U/EPDM article-No.	PVC-U/FPM article-No.
791.1	G 3/4	30097002	30097009
792.1	G 3/4	30097003	30097010
793.1	G 3/4	30097004	30097011
794.1	G 1	30097005	30097012
795.1	G 1 1/4	30097006	30097013
796.1	G 2 1/4	30097007	30097014
797.1	G 2 1/4	30097008	30097015

Options/Accessories			791.1 792.1	x	793.1 up to 797.1	x
Vent elbow 	G 3/4	PVC-U	▲		-	
	G 1	PVC-U	-		▲	
▲ = with add. price			- = not available			



731 to 736 in survey

- Compact design
- Easy to mount
- Maintenance free
- Hardly any wear and tear
- High-quality materials

Infobox

- Order information [Page 3.79](#)
- Options/accessories [Page 3.79](#)
- resistance chart [Chapter 5](#)
- installation examples [Chapter 5](#)

Technical data

Type	Nominal width DN	Max. admissible operating pressure bar
731	8	10
732	15	10
733	20	3
734	25	3
735	32	2
736	40	2

Dimensional drawing

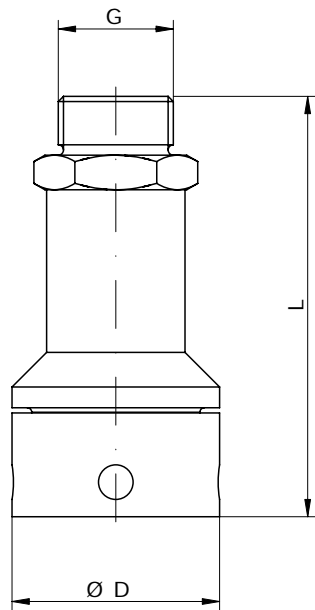

Dimensional chart

All indications in mm

Type	G	D		L
		PVC-U	PP/PVDF/1.4571	
731	G 3/4	31	30	70
732	G 1	–	60	121
733	G 1 1/4	–	80	129
734	G 1 1/2	–	80	164
735	G 2	–	100	240
736	G 2 1/4	–	100	240

Weights on request

Order information
Foot valve

Basic design:



- Valve ball:
- Type 731 - 733 : Glass
- Type 734 - 736 : PTFE
- Valve seals:
- Type 731: EPDM
- Type 732 - 736: FPM
- Sieve: PFK
- Mesh size: 1 mm
- Connection: Thread

Type	Thread connection	Material			
		PVC-U/EPDM	PP	PVDF	
		article-No.	article-No.	article-No.	
731	G 3/4	37600236	–	–	
732	G 1	–	37600239	37600241	
733	G 1 1/4	–	37600243	37600245	
734	G 1 1/2	–	37600247	37600249	
735	G 2	–	37600251	37600253	
736	G 2 1/4	–	37600255	37600257	

Basic design:

- Valve balls:
- Type 731 - 734: 1.4401
- Type 735 - 736: PTFE
- Valve seals: EPDM
- Sieve: PFK
- Mesh size: 1 mm
- Connection: Thread

Type	Thread connection	Material 1.4571	
		article-No.	
731	G 3/4	37600258	
732	G 1	37600259	
733	G 1 1/4	37600260	
734	G 1 1/2	37600261	
735	G 2	37600262	
736	G 2 1/4	37600263	

Options/Accessories			731	732	733	734	735	736
			●	○	○	○	○	○
Valve sealings 	PVC-U	EPDM	●	–	–	–	–	–
		FPM	○	–	–	–	–	–
	PP/PVDF	EPDM	–	○	○	○	○	○
		FPM	–	●	●	●	●	●
	1.4571	EPDM	●	●	●	●	●	●
		FPM	○	○	○	○	○	○
Valve balls 	PVC-U	Glass	●	–	–	–	–	
		1.4401	○	–	–	–	–	
	PP/PVDF	Glass	–	●	–	–	–	
		PTFE	–	▲	●	●	●	
	1.4401	1.4401	–	○	○	○	–	
		1.4401	●	●	●	●	–	
1.4571	PTFE	–	▲	▲	▲	●		

● = Basic design

○ = without add. price

– = not available

▲ = with add. price



732.2 to 737.2 in survey

- Compact design
- Easy to mount
- Maintenance-free
- Hardly any wear and tear
- High-quality materials

Infobox

- Order information [Page 3.81](#)
- Options/accessories [Page 3.81](#)
- resistance chart [Chapter 5](#)
- installation examples [Chapter 5](#)

Technical data

Type	Nominal width DN	Max. admissible operating pressure bar
732.2	15	16
733.2	20	16
734.2	25	16
735.2	32	16
736.2	40	16
737.2	50	16

Dimensional drawing

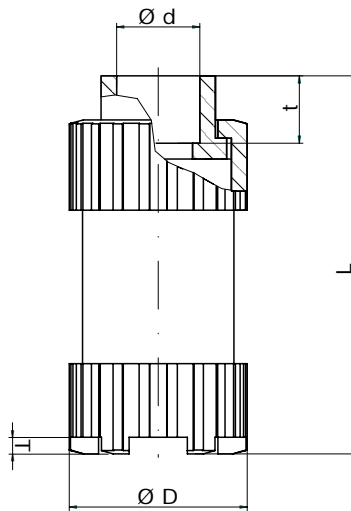

Dimensional chart

All indications in mm

Type	d	D	L	t	T
732.2	20	46	92	16	4
733.2	25	56	109	19	4.5
734.2	32	67	118	22	5
735.2	40	82	133	26	5.5
736.2	50	98	144	31	5.5
737.2	63	120	177	38	10

Weights on request

Order information
Foot valve

Basic design:

- Valve ball: PVC-U/
- Sieve: PFK
- Mesh size: 1mm
- Connection: Glueing bush

Type	Connection for pipe d	Material			
		PVC-U/EPDM		PVC-U/FPM	
		article-No.		article-No.	
732.2	20	30084154		30084155	
733.2	25	30084156		30084157	
734.2	32	30084158		30084159	
735.2	40	30084160		30084161	
736.2	50	30084162		30084163	
737.2	63	30084164		30084165	

Options/Accessories	732.2 up to 736.2	737.2
Valve balls  PTFE	▲	⓪
▲ = with add. price	⓪ = on request	



781.1 to 783.1 in survey

- Compact design
- Easy to mount
- Maintenance-free
- Hardly any wear and tear
- High-quality materials

Infobox

- Order information [Page 3.83](#)
- Options/accessories [Page 3.83](#)
- resistance chart [Chapter 5](#)
- installation examples [Chapter 5](#)

Technical data

Type	Nominal width DN	Max. admissible operating pressure bar
781.1	8	10
783.1	20	10

Dimensional drawing

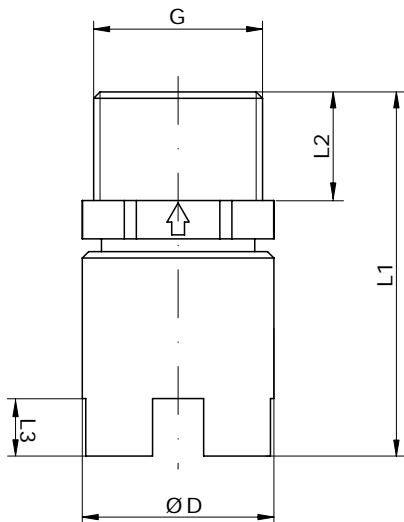

Dimensional chart

All indications in mm



Type	G	D	L1	L2	L3	Weight kg	
						PP-FRP	PVDF-FRP
781.1	G 3/4	30	50	18	6	0,02	0,04
783.1	G 1 1/4	50	80	25	6	0,05	0,2

Order information
Foot valve

Basic design

- Ball: Glass
- Sieve: PFK
- Mesh size: 1mm
- Seal: FPM

Type	Nominal width DN	Material	
		PP/PP-FRP article-No.	PVDF/PVDF-FRP article-No.
781.1	8	30073003	30073006
783.1	20	30073011	30073016

Options/Accessories		781.1	783.1	x
Valve balls 	Glass	●		
	1.4401	○		
	PTFE	▲		
Valve sealings 	FPM	●		
	EPDM	○		
	FEP-covered	▲		
● = Basic design ○ = without add. price ▲ = with add. price				



751.1 to 757.1 in survey

- Compact design
- Easy to mount
- Easy to maintain
- No wear and tear
- High-quality materials

Infobox

- Order information [Page 3.85](#)
- Options/accessories [Page 3.85](#)
- resistance chart [Chapter 5](#)
- installation examples [Chapter 5](#)

Technical data

Type	Nominal width	Max. admissible operating pressure	Mesh size
	DN	bar	mm
751.1	10	10	0.5
752.1	15	10	0.5
753.1	20	10	0.5
754.1	25	10	0.5
755.1	32	10	0.5
756.1	40	10	0.5
757.1	50	10	0.5

Dimensional drawing

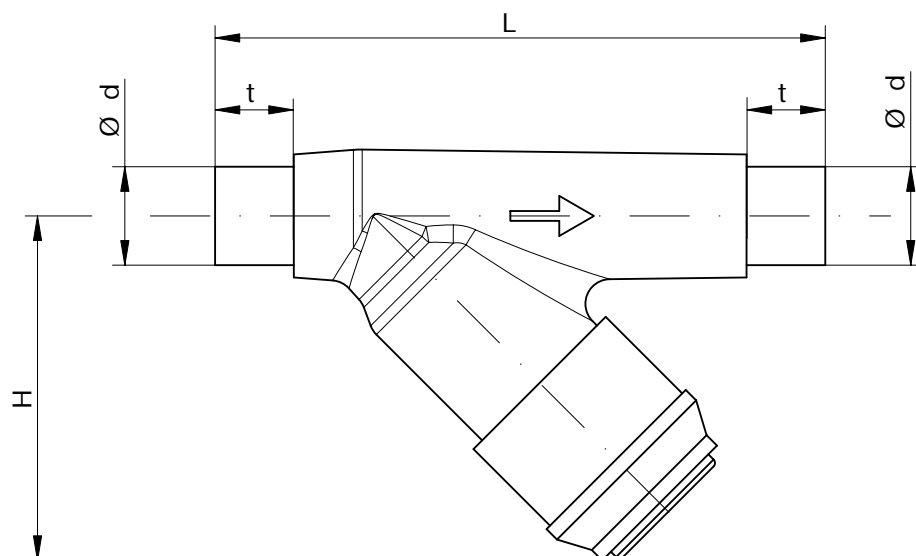

Dimensional chart

All indications in mm

Type	d	L	H	t		Weight kg		
				PVC-U	PP/PVDF	PVC-U	PP	PVDF
751.1	16	114	72	14	–	0.11	–	–
752.1	20	124	75	16	14.5	0.12	0.084	0.156
753.1	25	144	80	19	16	0.19	0.133	0.247
754.1	32	154	90	22	18	0.285	0.2	0.371
755.1	40	174	110	26	20.5	0.4	0.28	0.52
756.1	50	194	128	31	23.5	0.6	0.42	0.78
757.1	60	224	150	38	27.5	0.945	0.662	1.229

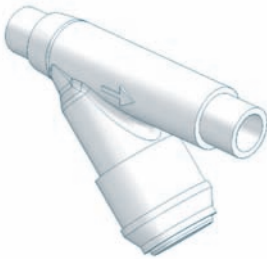
Order information
Line strainer

Basic design:

- Sieve material: with PVC-U made of PVC-U / PP and PVDF made of FEP
- mesh size 0,5 mm
- Connection:
- PVC-U = glued bushing
- PP, PVDF = welded bushing

Type	Connection d	Material									
		PVC-U/EPDM		PVC-U/FPM		PP/EPDM		PP/FPM		PVDF/FPM	
		article-No.		article-No.		article-No.		article-No.		article-No.	
751.1	16	30001005		30001006		–		–		–	
752.1	20	37601246		37601252		37601224		37601219		37601258	
753.1	25	37601247		37601253		37601225		37601220		37601259	
754.1	32	37601248		37601254		37601226		37601175		37601260	
755.1	40	37601249		37601255		37601227		37601221		37601261	
756.1	50	37601250		37601256		37601228		37601222		37601262	
757.1	60	37601251		37601257		37601229		37601223		37601263	



752 to 757 in survey

- Compact design
- Easy to mount
- Easy to maintain
- No wear and tear
- High-quality materials

Infobox

- Order information [Page 3.87](#)
- Options/accessories [Page 3.87](#)
- resistance chart [Chapter 5](#)
- installation examples [Chapter 5](#)

Technical data

Type	Nominal width	Max. admissible operating pressure	Mesh size
	DN	bar	mm
752	15	40	0.5
753	20	40	0.5
754	25	40	0.5
755	32	40	0.5
756	40	40	0.5
757	50	40	0.5

Dimensional drawing

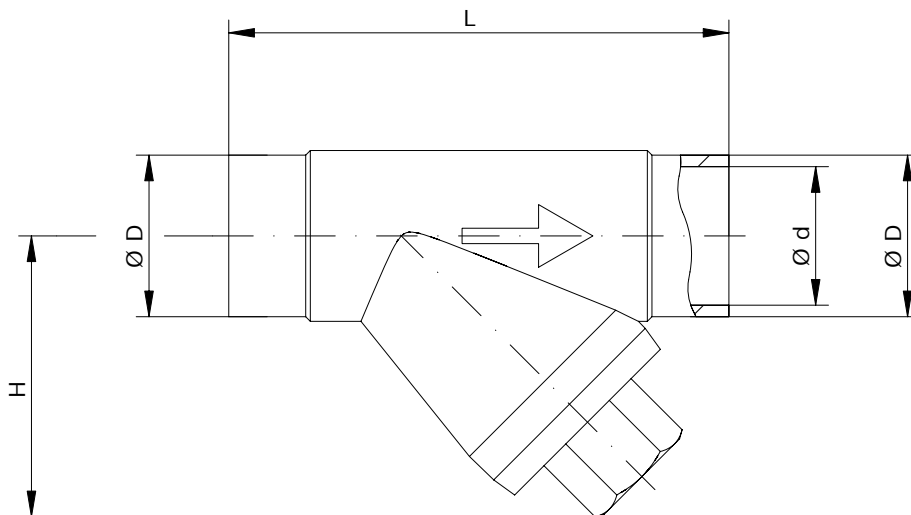

Dimensional chart

All indications in mm

Type	d	D	L	H
752	18,1	21.3	65	43
753	23,7	26.9	75	49
754	29,7	33.7	90	58
755	38,4	42.4	110	65
756	44,3	48.3	120	74
757	55,1	60.3	150	85

Weights on request

Order information
Line strainer

Basic design:

- Housing-, Covermaterial: 1.4408
- Sieve material: 1.4301
- Seals made of PTFE, connection: welding end
- Mesh size 0,5 mm

Type	Connection d	Material 1.4408	
		article-No.	
752	18,1	30002013	
753	23,7	30003013	
754	29,7	30004013	
755	38,4	30005011	
756	44,3	30006011	
757	55,1	37600268	



871 to 877 in survey

- Compact design
- Easy to mount
- Low-maintenance
- Hardly any wear and tear
- High-quality materials

Infobox

- Order information [Page 3.89](#)
- Options/accessories [Page 3.89](#)
- resistance chart [Chapter 5](#)
- installation examples [Chapter 5](#)

Technical data

Type	Nominal width DN	Max. admissible inlet pressure bar
871	10	10
872	15	10
873	20	10
874	25	10
875	32	10
876	40	10
877	50	10

Dimensional drawing

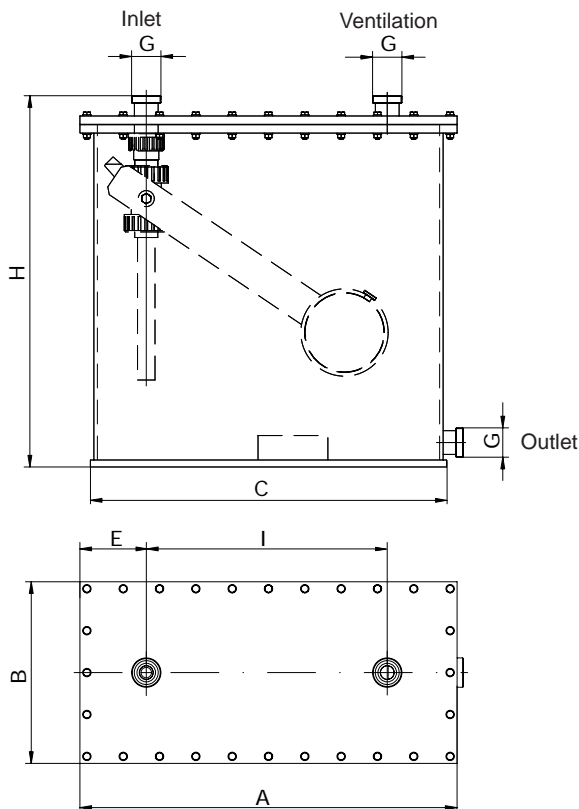

Dimensional chart

All indications in mm

Type	G	H	A	B	C	E	I
871	G 3/4	394	405	190	375	80	230
872	G 1	537	540	260	520	95	345
873	G 1 1/4	537	540	260	520	95	345
874	G 1 1/2	537	540	260	520	95	345
875	G 2	630	688	340	612	123	363
876	G 2 1/4	630	688	340	612	123	363
877	G 2 3/4	733	759	360	705	140	374

Weights on request

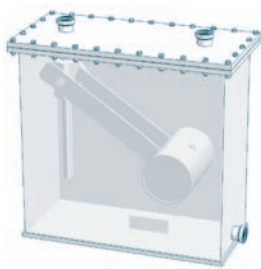
Order information
Float valve

Basic design:

- Cover seal made of CSM (Hypalon)

Type	Thread connection	Material	
		PVC-U/EPDM article-No.	PVC-U/FPM article-No.
871	G 3/4	37600275	37600276
872	G 1	37600279	37600280
873	G 1 1/4	37600283	37600284
874	G 1 1/2	37600287	37600288
875	G 2	37600291	37600292
876	G 2 1/4	37600295	37600296
877	G 2 3/4	37600299	37600300

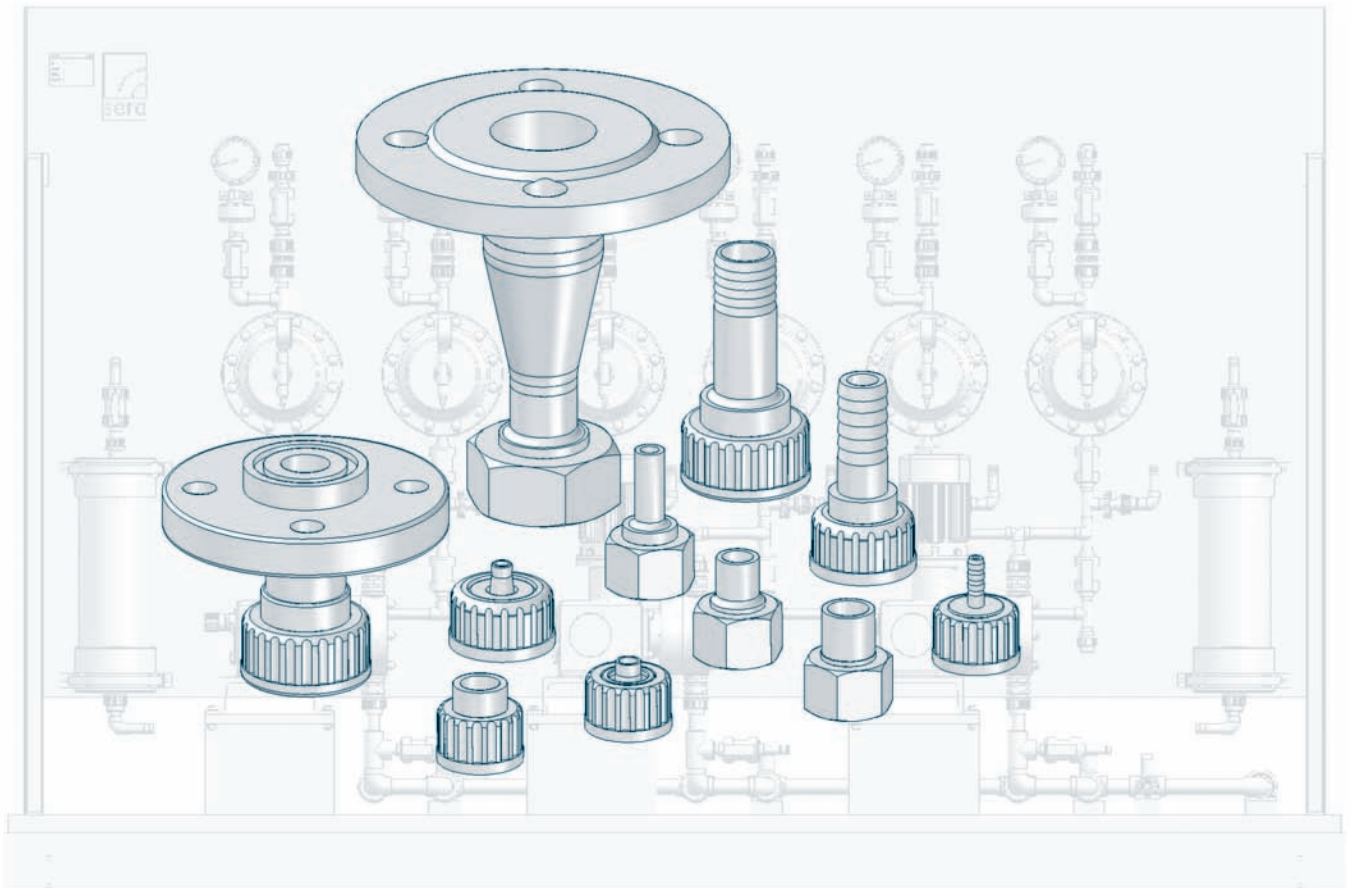
Options/Accessories		871 up to 877	x
Cover seal 	CSM	●	
	FPM	▲	
● = Basic design		▲ = with add. price	



Connection design	Chapter content	Page
Inserts	Inserts with union nut made of different plastics	4.2
Welding joints	Pipe sockets with union nut made of stainless steel	4.3
Flange connections	Transition pieces with loose flange	4.4
	Transition pieces with fixed flange	4.5
Hose connections	Hose nozzles with union nut	4.6
	Hose screwings	4.7
Accessories	Dosing hoses	4.8
	Hose clamps	4.10

Order information

Inserts with union nut

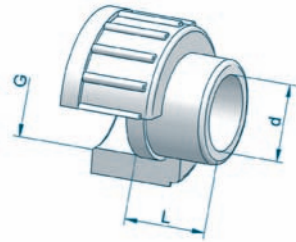

Screwed connection G	Nominal width DN	Diameter d	L PVC-U	L PP/PVDF	PVC-U		PP		PVDF	
					article-No.	x	article-No.	x	article-No.	x
G 3/4	8	12	17	–	90003796		–		–	
G 3/4	10	16	17	18	90003797		90003805		90003804	
G 3/4	15	20	60	60	90003543		90003544		90003546	
G 1	15	20	19	19	90003798		90003808		90003807	
G 1 1/4	15	20	22	21	90004622		90004620		90004621	
G 1 1/4	20	25	22	21	90003799		90003811		90003810	
G 1 1/4	25	32	74	70	90004626		90004624		90004625	
G 1 1/2	25	32	25	23	90003800		90003814		90003813	
G 2	32	40	29	25	90003801		90003817		90003816	
G 2 1/4	40	50	34	28	90003802		90003820		90003819	
G 2 3/4	50	63	41	32	90003803		90003823		90003822	

– = not available

Material design

- PVC-U-insert:
 - Union nut made of:
 - PP-FRP (with G 3/4, G 1, G 1 1/4)
 - PVC-U (with G 1 1/2 to G 2 3/4)
- PP-insert:
 - Union nut made of:
 - PP-FRP (with G 3/4, G 1, G 1 1/4)
 - PP (with G 1 1/2 to G 2 3/4)
- PVDF-insert:
 - Union nut made of:
 - PVDF-FRP (with G 3/4, G 1, G 1 1/4)
 - PVDF (with G 1 1/2 to G 2 3/4)

Order information

Pipe socket with union nut

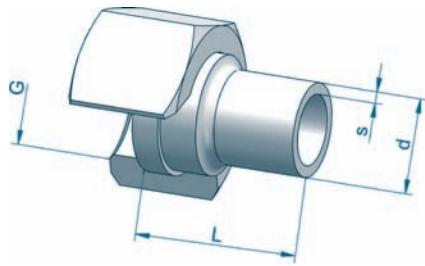

Screwed connection G	Nominal width DN	Diameter d x s	L	1.4571 article-No.	x
G 3/4	15	10 x 2,0	30	90003831	
G 3/4	15	12 x 2,0	30	90003832	
G 3/4	15	17,2 x 2,0	30	90008740	
G 3/4	15	21,3 x 2,0	30	90008741	
G 1	20	21,3 x 2,0	35	90008743	
G 1	20	26,9 x 2,5	35	90015935	
G 1 1/4	25	21,3 x 2,0	35	90008744	
G 1 1/4	25	26,9 x 2,5	35	90008745	
G 1 1/4	25	33,7 x 3,0	35	90008746	
G 1 1/2	25	33,7 x 3,0	37	90008747	
G 2	32	38 x 3,0	69	90003845	
G 2 1/4	40	44,5 x 2,0	70	90003847	

Material design

- Pipe socket: 1.4571
- Union nut: 1.4571

Order information

Transition piece with loose flange

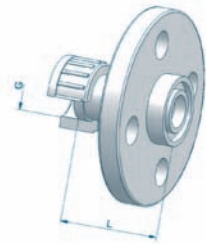

Screwed connection G	Nominal width flange ANSI B16,5	L PVC-U	L PP/PVDF	PVC-U/FPM		PP/FPM		PVDF/FPM	
				article-No.	x	article-No.	x	article-No.	x
G 3/4	10	45	46	90003790		90003788		90003789	
G 3/4	15	45	46	90003793		90003791		90003792	
G 1	15	52	50	90005808		90005809		90005810	
G 1 1/4	15	51	53	90005707		90005705		90005706	
G 1 1/4	20	51	53	90005704		90005702		90005703	
G 1 1/4	25	51	53	90005701		90005699		90005700	

Material design

- PVC-U-design:
 - Loose flange: PVC-U
 - Union nut: PP-FRP
- PP-design:
 - Loose flange:
 - FRP (with DN10)
 - PP with steel insert (as of DN15)
 - Union nut: PP-FRP
- PVDF-design:
 - Loose flange:
 - FRP (with DN10)
 - PP with steel insert (as of DN15)
 - Union nut: PVDF-FRP

Flange connecting dimensions

- acc. DIN 2501, PN10

Connection sealings

- FPM = Basic design
- EPDM = available without add. price

Order information

Transition piece with fixed flange

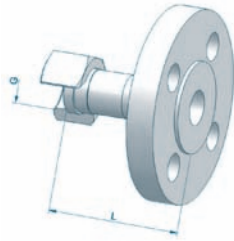

Screwed connection G	Nominal width flange DIN2633	Nominal width flange ANSI B16,5	L DIN2633	L ANSI B16,5	1.4571 DIN2633		1.4571 ANSI B16,5	
					article-No.	✕	article-No.	✕
G 3/4	10	1/2"	65	77.8	90023375		90011472	
G 3/4	15	3/4"	65	120	90011412		90018303	
G 1	15	3/4"	67	87.3	90011414		90023332	
G 1 1/4	15	3/4"	70	87.5	90011418		90021801	
G 1 1/4	20	1"	73	90.6	90011420		90022289	
G 1 1/4	25	1 1/4"	73	142.2	90011422		90021802	

Material design

- Union nut: 1.4571
- Flange: 1.4571

Flange dimensions:

- DIN 2633, PN16
- Ansi B 16,5; 150 lbs/sqin

Order information

Hose nozzle with union nut

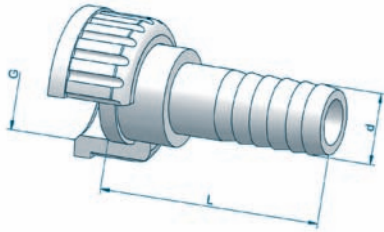

Screwed connection G	Nominal width DN	Diameter d	L	PVC-U		PP		PVDF		1.4571	
				article-No.	✘	article-No.	✘	article-No.	✘	article-No.	✘
G 3/4	3	6,5	30	90003871		90003869		90003870		90003872	
G 3/4	5	10	35	90003875		90003873		90003874		90003876	
G 3/4	8	12	54	90003879		90003877		90003878		90003880	
G 3/4	10	16	60	90003883		90003881		90003882		90003884	
G 3/4	15	20	65	90003887		90003885		90003886		90003888	
G 1	8	13	57	90010434		–		–		–	
G 1	15	20	65	90003891		90003889		90003890		90003892	
G 1 1/4	15	20	65	90004633		90004631		90004632		90004634	
G 1 1/4	20	25	82	90003895		90003893		90003894		90003896	
G 1 1/4	25	30	92	90004637		90004635		90004636		90004638	
G 1 1/2	25	30	92	90003899		90003897		90003898		90003900	
G 2	32	40	103	90003903		90003901		Ⓢ		90003904	
G 2 1/4	40	50	120	90003907		Ⓢ		Ⓢ		Ⓢ	

– = not available Ⓢ = on request

Material design

- PVC-U-hose nozzle
 - Union nut made of:
 - PP-FRP (with G 3/4, G 1, G 1 1/4)
 - PVC-U (with G 1 1/2 to G 2 1/4)
- PP-hose nozzle
 - Union nut made of:
 - PP-FRP (with G 3/4, G 1, G 1 1/4)
 - PP (with G 1 1/2 to G 2 1/4)
- PVDF-hose nozzle
 - Union nut made of:
 - PVDF-FRP (with G 3/4, G 1, G 1 1/4)
 - PVDF (with G 1 1/2 to G 2 1/4)
- 1.4571-hose nozzle
 - Union nut made of:
 - 1.4571

Order information

Hose screwing for PVC-U-hose with cross-textile ply

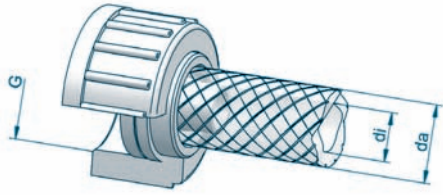

Screwed connection G	Diameter hose di	Diameter hose da	PVC-U article-No.	x
G 3/4	6	12	90011092	
G 3/4	10	16	90011093	
G 1	16	24	90011094	
G 1	10	16	90011099	
G 1 1/4	16	24	90011095	
G 1 1/4	19	27	90011096	

Material design

- Nozzle and supporting bushes: PVC-U
- Union nut: PP-FRP

Hose screwing for PE- and PTFE-hose

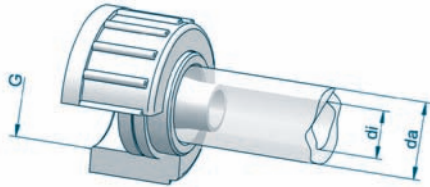

Screwed connection G	Diameter hose di	Diameter hose da	PP article-No.	x	PTFE article-No.	x	PVC-U article-No.	x	PTFE/PVC-U article-No.	x	PTFE/PP article-No.	x
G 3/4	4	6	90011697		90023329		90016022		90023330		90016122	
G 3/4	5	8	90016089		–		90018741		–		90017660	
G 3/4	8	12	90015981		90017566		90025703		90023331		90017834	
G 3/4	10	12	90016415		90019622		90017815		90015256		90018910	

– = not available

Material design

- Nozzle and supporting bushes: PP
 - Union nut: PP-FRP
- Nozzle and supporting bushes: PVC-U
 - Union nut: PVC-U
- Nozzle and supporting bushes: PTFE
 - Union nut: PTFE
- Nozzle: PTFE
 - Supporting bushes and Union nut: PVC-U
- Nozzle: PTFE
 - Supporting bushes: PP
 - Union nut: PP-FRP

Order information

Dosing hose made of PVC-U with cross-textile ply

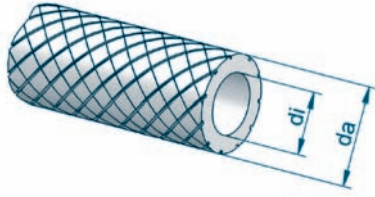

Diameter hose nozzle	Hose di (internal)	Hose da (external)	up to max	Max. Length m	PVC-U article-No.	✕
6.5	6	12	10	50	90005974	
10	10	16	10	50	90005975	
12	12	21	10	50	90005976	
16	16	24	10	50	90005977	
20	19	27	10	50	90005978	
25	25	34	9	25	90005979	
30	30	38	6	25	90010204	
40	38	48	6	25	90005981	

■ Available as yard ware (please note max. length)

Dosing hose made of EPDM

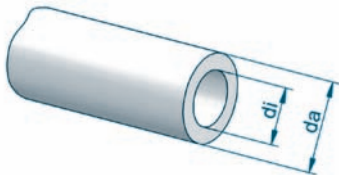

Diameter hose nozzle	Hose di (internal)	Hose da (external)	Min. permiss. pressure bar	up to max	Max. Length m	EPDM article-No.	✕
13	13	20	-0.3	10	40	90009835	
20	19	27	-0.3	10	40	90010443	
25	25	34	-0.3	10	40	90014695	

- Core and external cover made of black EPDM
- Available as yard ware (please note max. length)
- Only for connection with hose nozzle and hose clamps

Order information

Dosing hose made of PE and PTFE

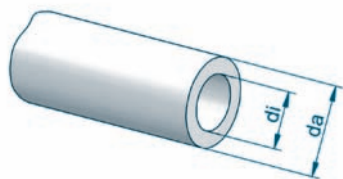

Hose di (internal)	Hose da (external)	up to max	Max. Length m	PE article-No.	PTFE article-No.
4	6	10	100	90005503	–
4	6	15	30	–	90007737
5	8	10	100	90007740	90007743
8	12	10	100	90007742	–
10	12	11	20	–	90007738

– =not available

- Available as yard ware (please note max. length)
- Only for connection with hose screwing

Dosing hose made of XLPE

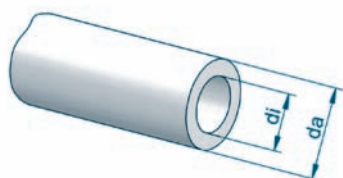

Diameter hose nozzle	Hose di (internal)	Hose da (external)	Min. permiss. pressure bar	up to max	Max. Length m	XLPE article-No.
20	19	34	-0.9	10	40	90010399
25	25	41	-0.9	10	40	90017980

- Core made of crosslinked polyethylene (XLPE)
- External cover made of green EPDM with steel spiral
- Available as yard ware (please note max. length)
- Only for connection with hose nozzle and hose clamps

Hose clamp

Order information

Hose clamp

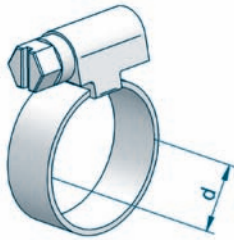

Width d (min)	Width d (max)	for hose up to da	W4 article-No.	<input type="checkbox"/>
10	16	16	90002343	
16	27	24	90002345	
20	32	27	90002346	
32	50	48	90002348	

- With worm drive
- DIN3017

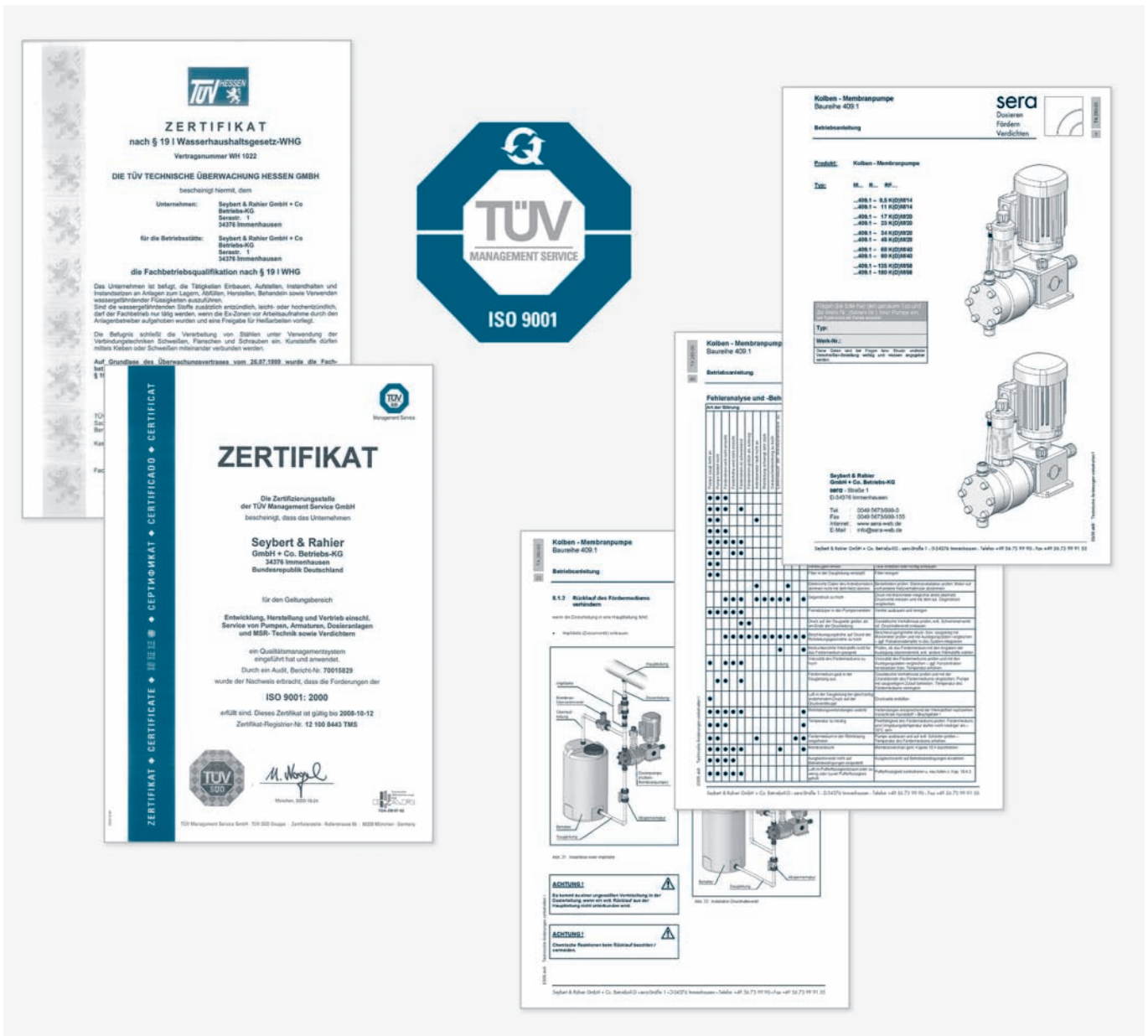

General information	Chapter content	Page
Use of product catalogue/Order system	Use of product catalogue Inquiry-/Orderform Questionnaire Dosing- and Feeding pumps	5.2
Resistance chart	Overview of the resistance of different materials in connection with different chemicals	5.6
Installation examples	Typical installation of dosing pumps in connection with fittings	5.16
Product-Documentation	sera – Productdocumentation acc. to EU-Machinery directive 98/37/EC	5.21
Certificates	TÜV-Certificate ISO 9001:2000 Specialist company acc. to §19 WHG	5.22

1. Table of contents

Please choose your product chapter in our table of contents

Dosieranlagen und -systeme	Kapitel 1
Dosier- und Förderpumpen	Kapitel 2
Armaturen	Kapitel 3
Anschlüsse und Dosierhilfsbaue	Kapitel 4
Allgemeine Informationen	Kapitel 5



2. Chapter overview

Via the application, description and type range of capacity you will find the product overview.



3. Product overview

Please choose here your type series according to the required range of capacity

4. Product page

Please find here the technical data to the product.



5. Order information

Please mark a base product and the required options/accessories in the appropriate column, or use the Inquiry/Order form (see page 5.3).



Typ	Basisausführung	
R409.2-18e	16005264	
R409.2-25e	16005265	
R409.2-50e	16005266	X
R409.2-75e	16005267	
R409.2-90e	16005268	

Optionen/Zubehör	R409.2-18e	R409.2-25e	R409.2-50e	R409.2-75e	R409.2-90e
Multiweg-ventilierung mit Positionsanzeige	▲	▲	X	▲	▲
Multiweg-Überwachung 12-60V DC, Druckart, PNP	▲	▲	X	▲	▲
Nennur-Ausführung 600 Edine VCE, gem. ATEX 95	▲	▲	▲	▲	▲

6. Allocation of fittings

Via the allocation of fittings you will find the pressure and the suction-sided fittings to the pump.

7. Connection pieces

Please choose here the correct connection pieces to the product (see chapter 4).

8. Installation examples

For pumps and fittings (see chapter 5).

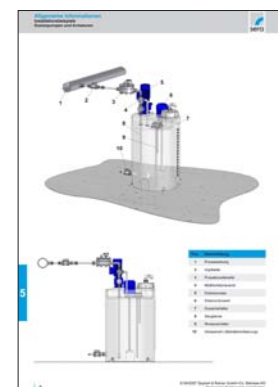

9. Resistance chart

Please choose the material suitable for the dosing medium with the help of the resistance chart (see chapter 5).



Beständigkeitsliste		Ace ... Ath		sera													
Medium	Chemische Formel	Konzentration Gew.-%	Temperatur °C	Leitfähigkeit > 1µS/cm	Dichte < 1 g/cm³	Chemische Beständigkeit											
						PP	PE	PVDF	PVDF-GFK	1.4571 / 1.4581	1.4401	1.4121 V	Glas	EPDM	CSM	PFM	PTFE
Aceton	CH ₃ CO-CH ₃	100	50	●	●	●	●	●	●	●	●	●	●	●	●	●	●
Alaun	KAL(SO ₄) ₃ ·12H ₂ O	12	40	●	●	●	●	●	●	●	●	●	●	●	●	●	●
Alaun	KAL(SO ₄) ₃ ·12H ₂ O	12	60	●	●	●	●	●	●	●	●	●	●	●	●	●	●
Aluminiumchlorid	AlCl ₃	30	40	●	●	●	●	●	●	●	●	●	●	●	●	●	●
Aluminiumchlorid	AlCl ₃	30	60	●	●	●	●	●	●	●	●	●	●	●	●	●	●

Inquiry Order **No.:** **Date:**

Customer data

Company:	Name: Phone: Fax: E-mail:
Project/Commission:	

Medium

Medium with Attributes: (Concentration, temperature, viscosity...)
--	----------------

Inquiry-/Orderinformation

Article (Basic design) Type	Options / Accessories		Article-No.	Piece/s
	Description	Specification		
R 409.2-18e	Valve balls	PTFE	16005264	1
	integrated relief valve	PP		1
	Hoze nozzle compl.	PP, d12	90003877	2
620.10			37600014	1

Remarks

.....

.....

.....
Place and date

.....
Stamp and signature

Customer data

Company:	Name: Phone: Fax: E-mail:
--	--

Medium

Medium ¹⁾	
Concentration (%)	Vapour pressure at operating temperature (bar)
Viscosity (mPas)	Solids content - size
Operating temperature max. (°C)	Operating temperature min. (°C)
Dosing accuracy (%)	Density (g/cm ³)

Operating data

Nominal capacity max. (l/h) ¹⁾	Nominal capacity min. (l/h)
Pressure at the pump pressure joint (bar) ¹⁾	Pressure at suction joint (bar) ¹⁾
Pressure line width (DN)	Total length of pressure line (m)
Suction line width (DN)	Total length of suction line (m)
Max. suction height (m WS)	Type of stroke adjustment
Material at pressure line	Material suction line

Motor data

Voltage (V)	Voltage type
Frequency (Hz)	Protection class (IP)

¹⁾ This is the minimum information required for an offer!

Remarks

.....

.....

.....

.....
Place and date

.....
Stamp and signature

5

Please use the following symbols



1 Suction tank



2 Shut-off valve



3 Line strainer



4 Dosing pump



5 Relief valve



6 Pressure-keeping valve



7 Pulsation damper



8 Manometer



9 Ball check valve

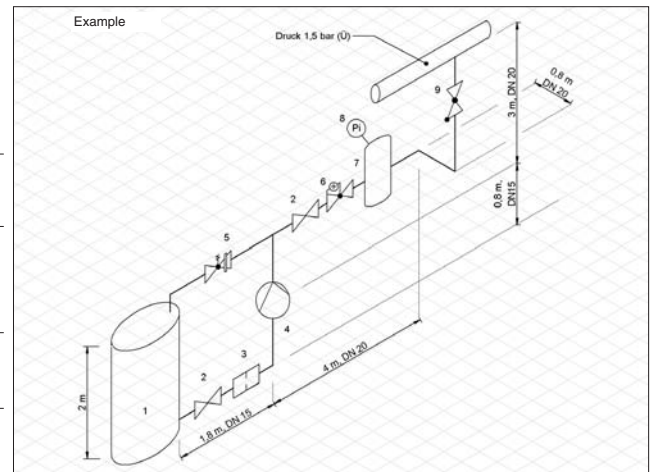

R+I-diagram (sketch)



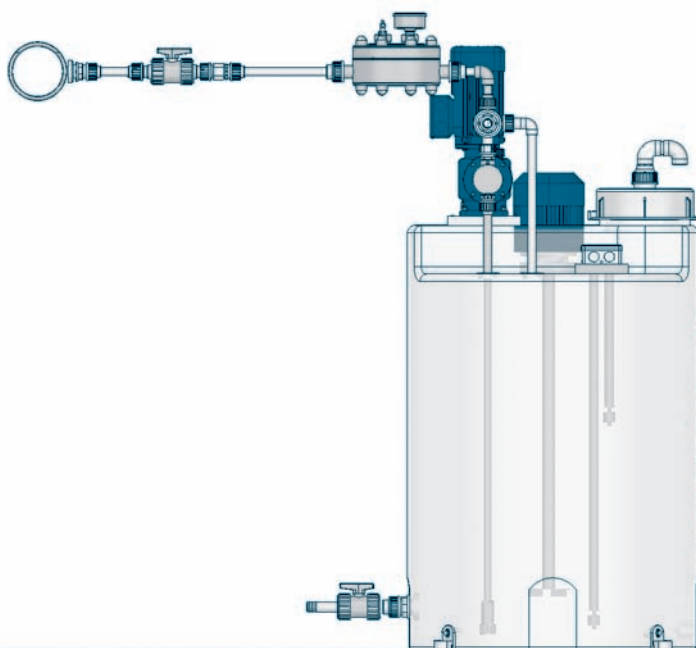
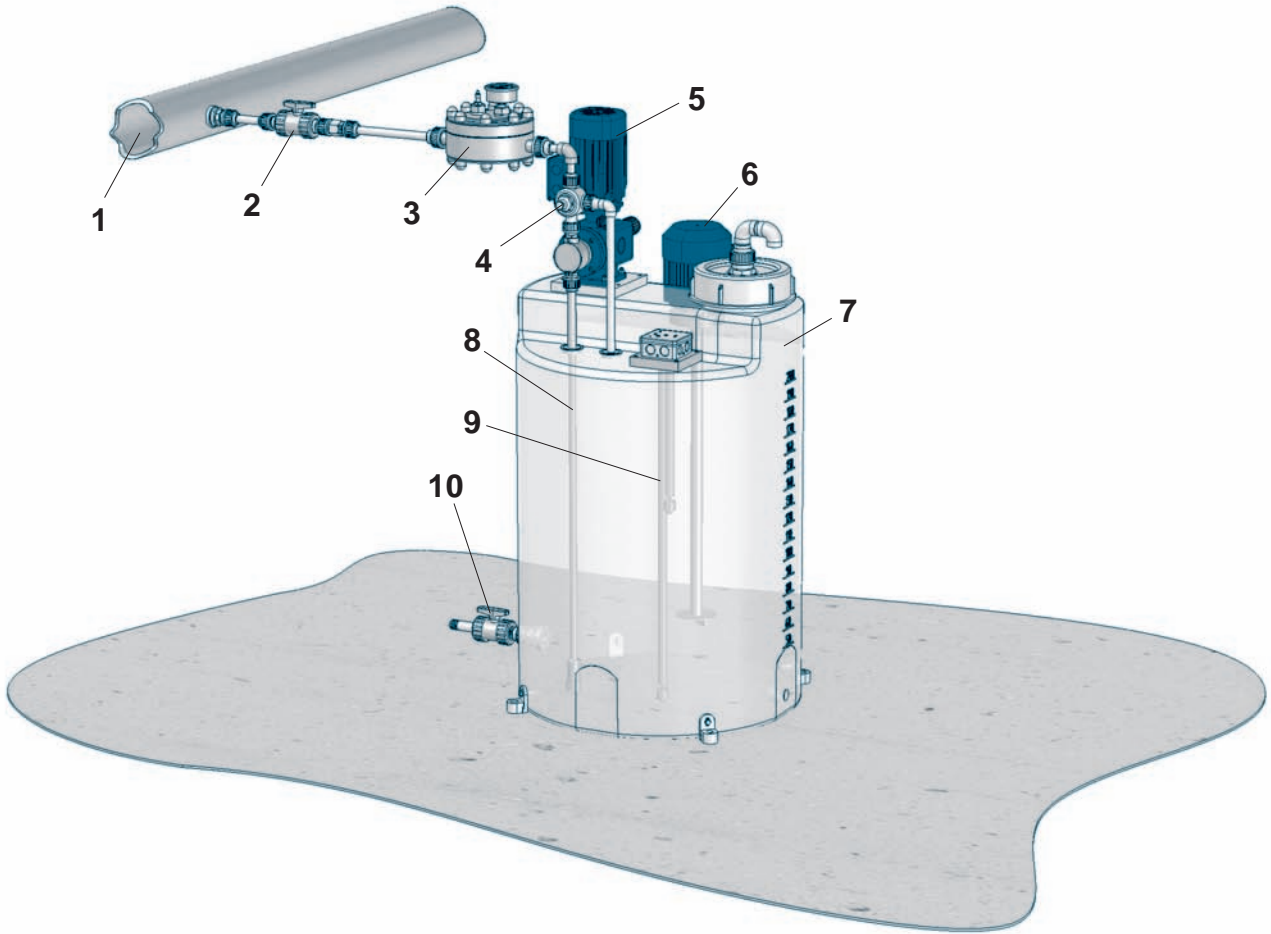

Pos.	Description
1	Process line
2	Injection fittings
3	Pulsation damper
4	Multi-function valve
5	Dosing pump
6	Electric agitator
7	Dosing tank
8	Suction lance
9	Level switch
10	Drain cock (tank evacuation)

5

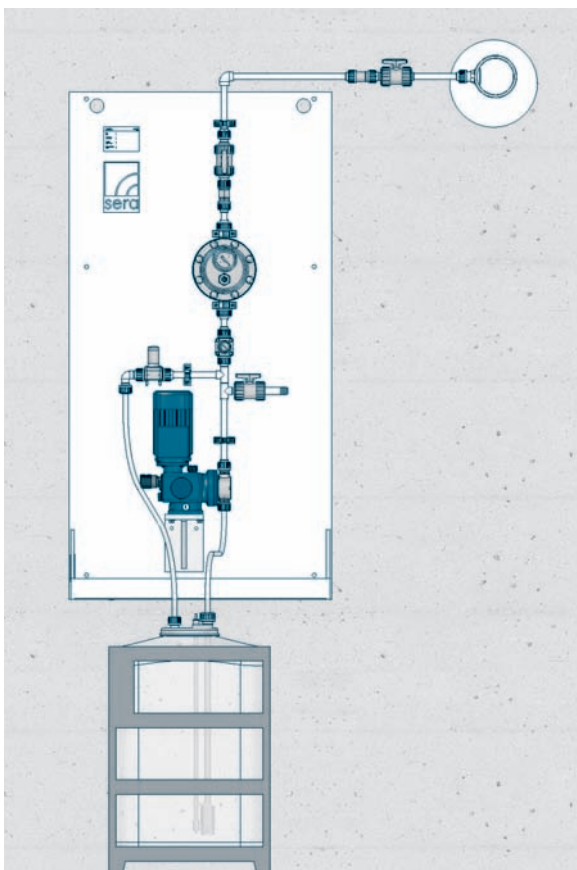
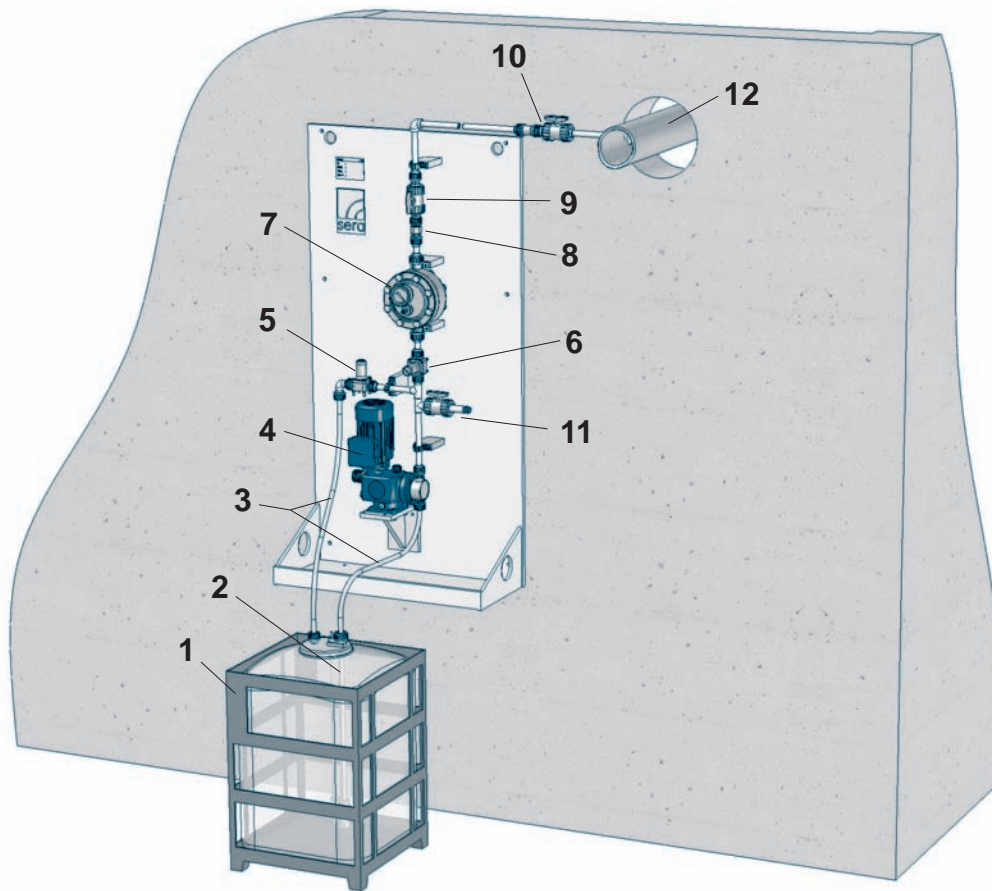

Pos.	Description
1	Chemical-tank
2	Suction lance
3	Dosing hose
4	Dosing pump
5	Relief valve
6	Pressure-keeping valve
7	Pulsation damper
8	Check valve
9	Shut-off valve
10	Injection fitting
11	Evacuation and pressure relief valve
12	Process line

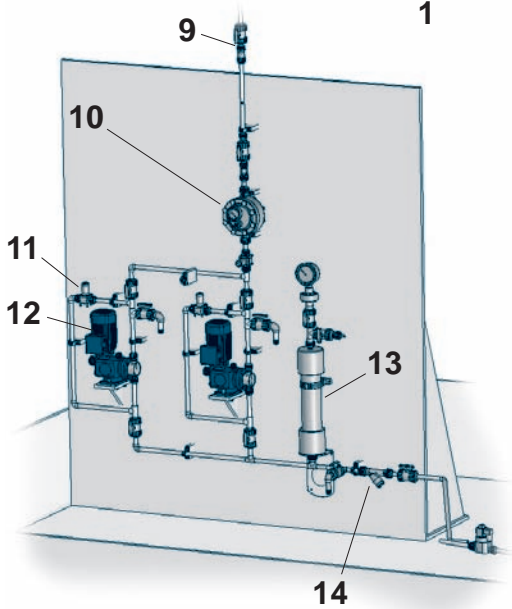
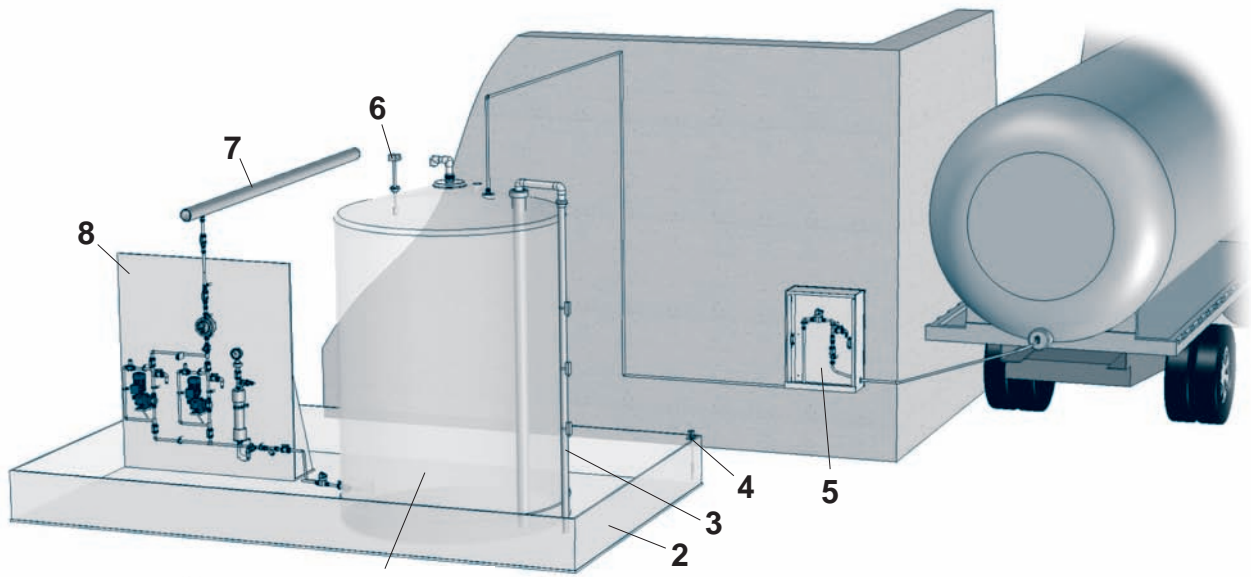

Pos.	Description
1	Storage tank
2	Collecting bassin
3	Level indicator
4	Leakage probe
5	Filling cabinet
6	Overfilling protection
7	Process line

Pos.	Description
8	Dosing pallet (base mounting)
9	Injection fitting
10	Pulsation damper (on the pressure side)
11	Relief valve(s)
12	Dosing pumps(s)
13	Pulsationsdämpfer (on the suction side)
14	Line strainer

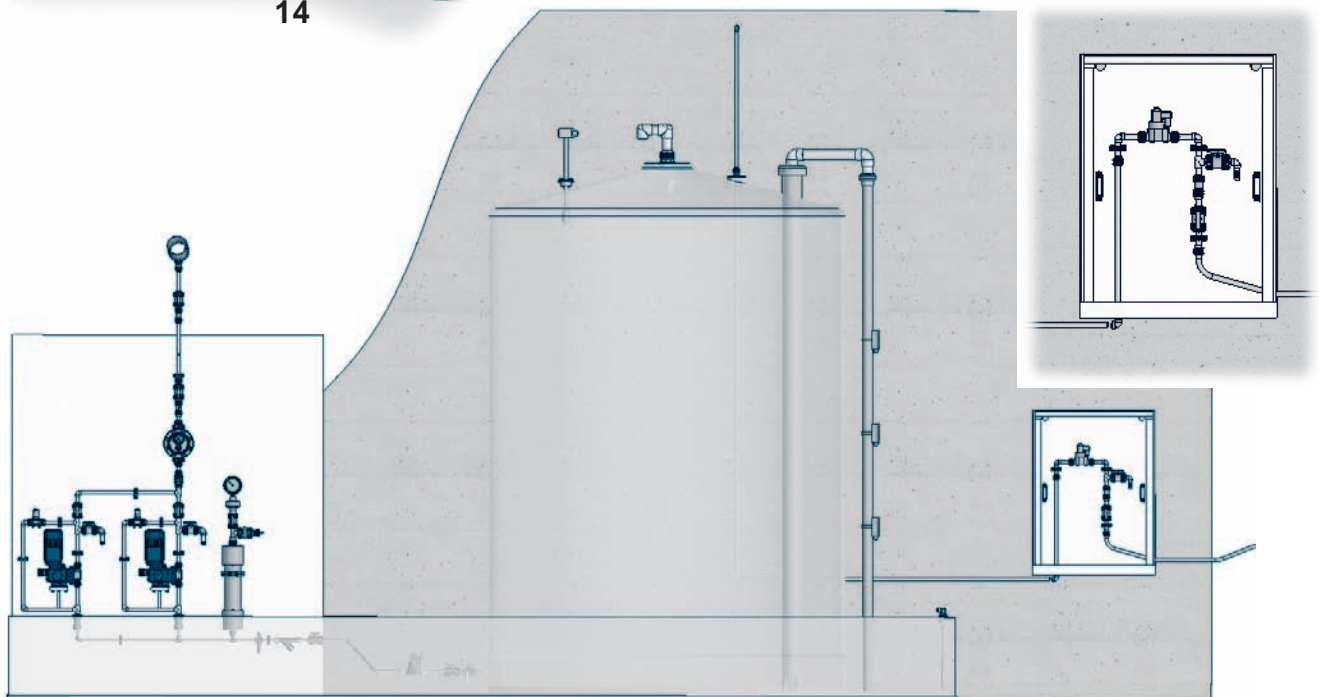

5

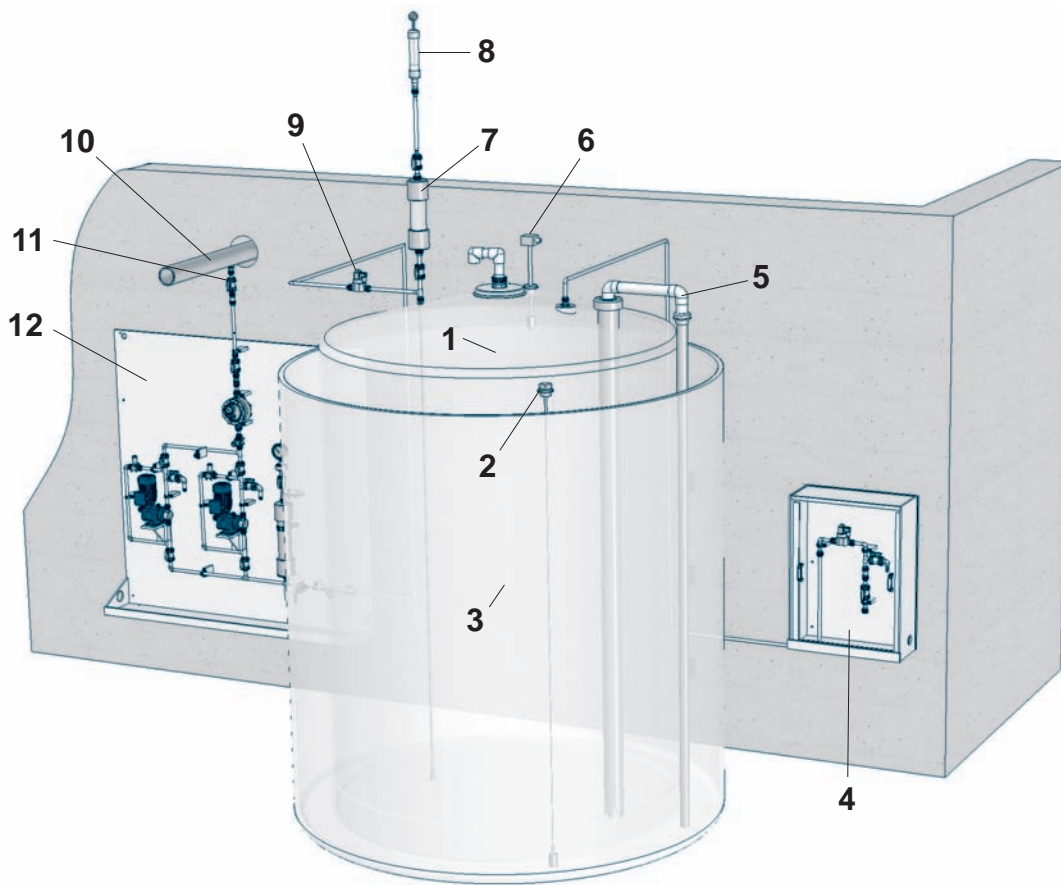

Pos.	Description
1	Storage tank
2	Leakage probe
3	Collecting basin
4	Filling cabinet
5	Level indicator
6	Overflowing protection

Pos.	Description
7	Siphon vessel
8	Hand vacuum pump
9	Automatic-fitting
10	Process line
11	Injection fitting
12	Dosing pallet (wall mounting)

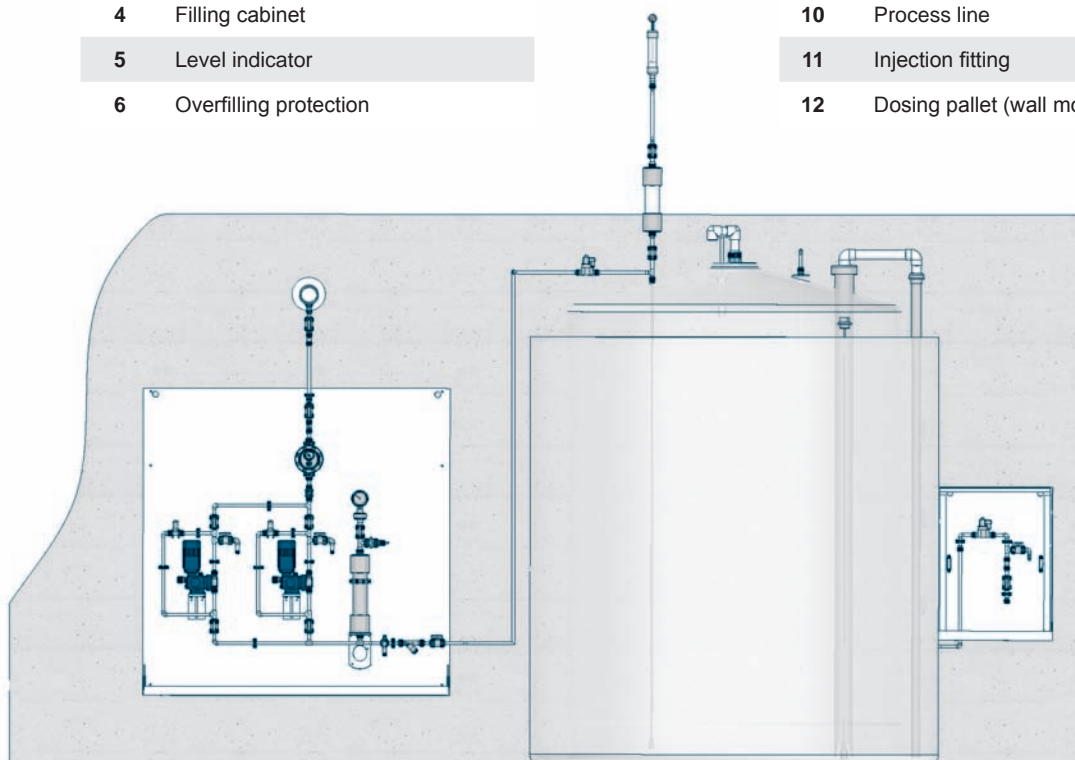

In general

s e r a - products from the current s e r a - catalogues are supplied with a product documentation that contains the following standard:

1. User's information:
 - Operating instructions (series)
 - Dimensional drawings (only for information)
 - Component drawings (only for information)
 - Component list (list of parts)
2. Quality documentation:
 - Inspection certificate covering pump test (for pumps without extra charge)
 - Declaration of conformity (without extra charge)
 - Declaration of manufacturer (without extra charge)
 - Testing certificate / Certificates (acc. to the specification for extra charge)

Language and quantity

The documentation is made in German and English language one-fold without extra charge.

Documentation in another language and multiple copies can be delivered on request for extra charge

Customized designs

s e r a - products as variation or product combinations from this products are delivered as modular product documentation

Used products and components are documented as above mentioned

Construction data

Drawings true to scale of s e r a - products as data sheet or drawing can be made on request for extra charge

External products

If available, product documentation of external products will be added in original, one-fold and according to our specification for documentation

Documentation-Specification

Product documentation can be made on request and for extra charge according to the customer specification

Electronic design

s e r a - product documentation can be changed to electronic data (pdf-file) on request for extra charge and can be sent on data medium or per e-mail

s e r a - construction data can be changed to electronic data (dxf-file) on request for extra charge and can be sent on data medium or per e-mail

Download

There is appropriate information (technical data sheet) about our range of products on the s e r a - homepage www.sera-web.de for download!

